

ABHINAV
KULKARNI's

automotive-
DESIGN

PORTFOLIO

2022

APPLICATION FOR FOLLING ROLES :

INTERNSHIP , TRANSPORTATION
DESIGNER (2WHELLER , EXT & INT)

Jr. TRANSPORTATION
DESIGNER

DIGITAL SURFACE DESIGNER

VISUALISATION AND
PACKAGING DRAWING

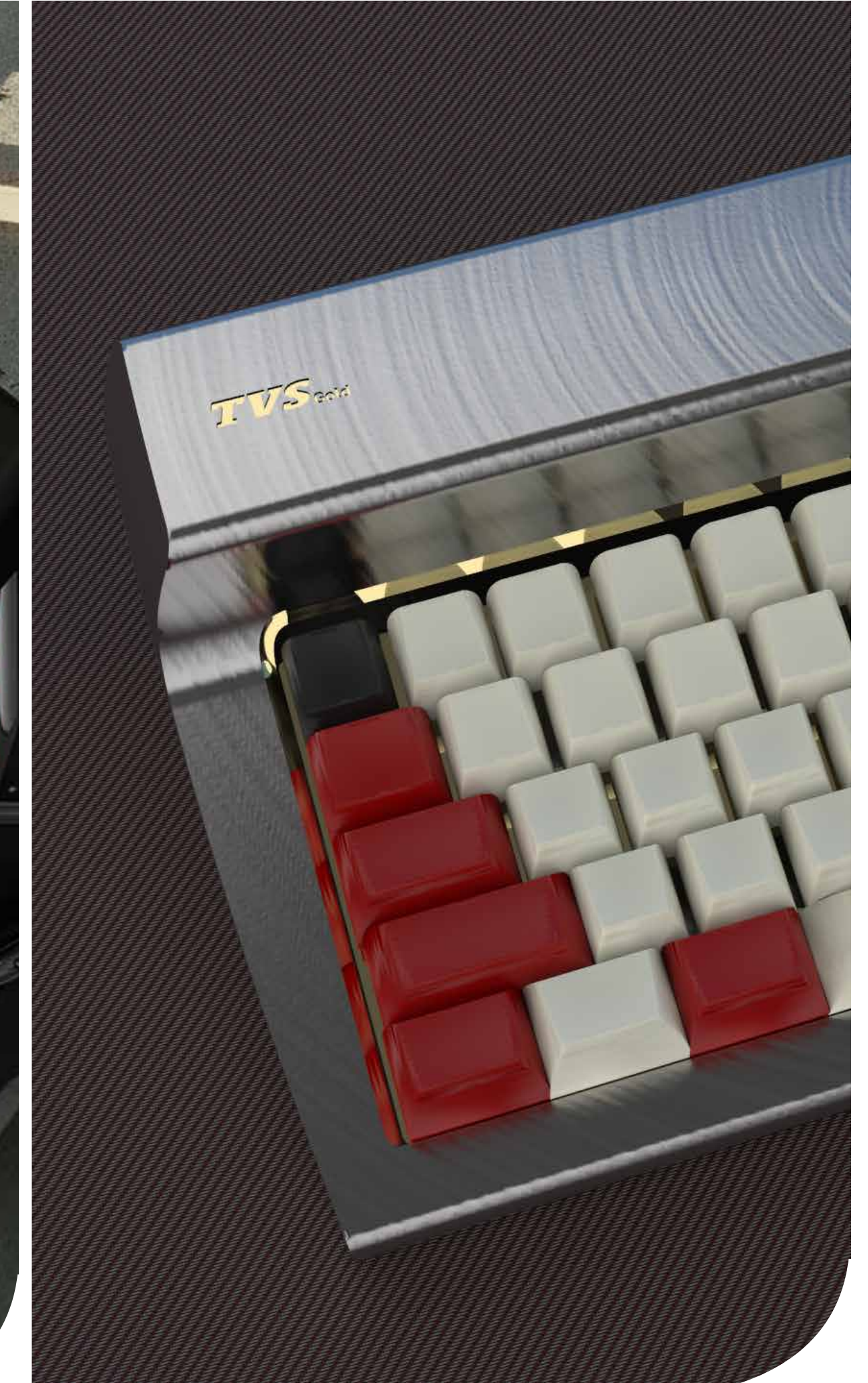

stage 1

AIM :

// "A lighter
Supermoto type

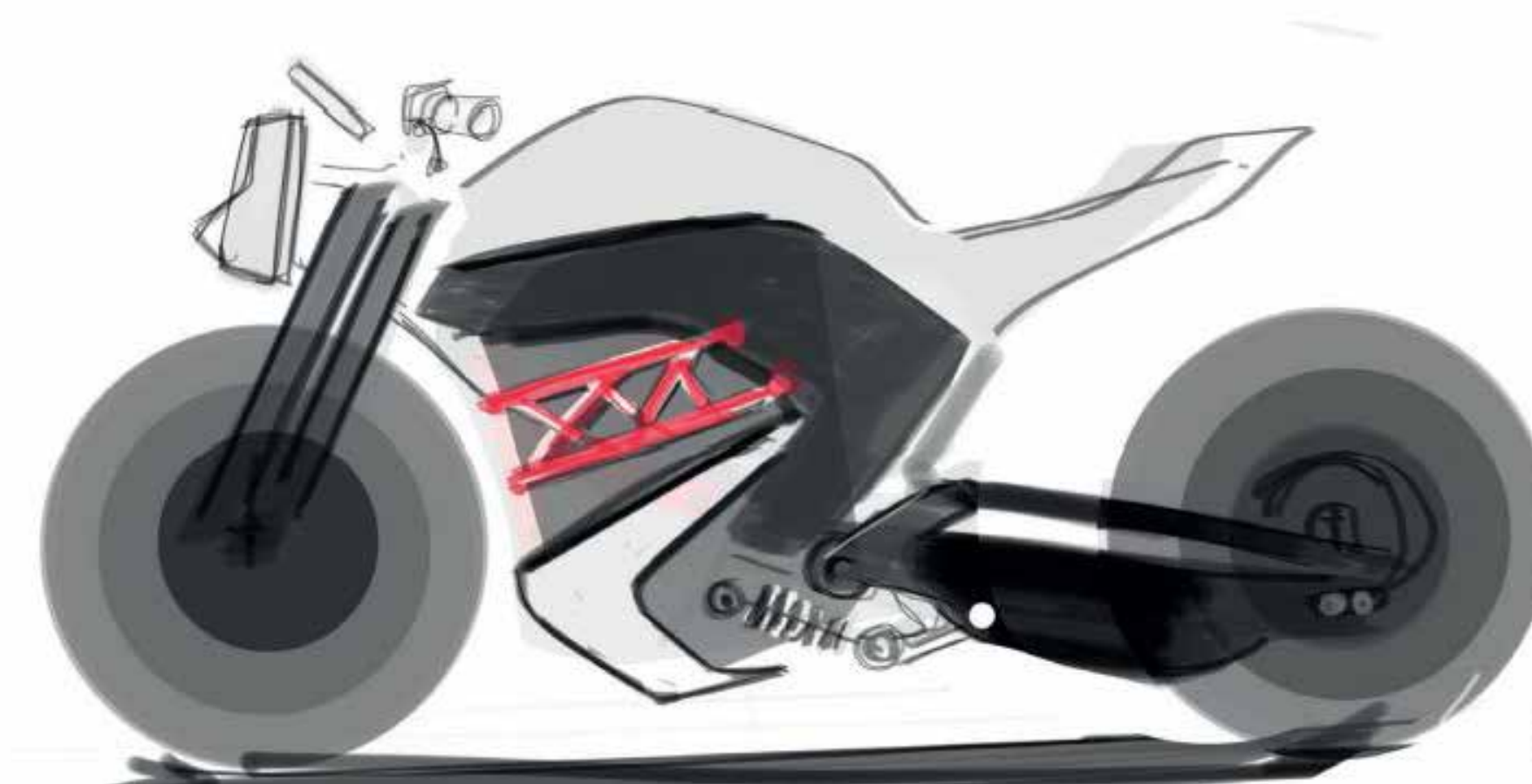
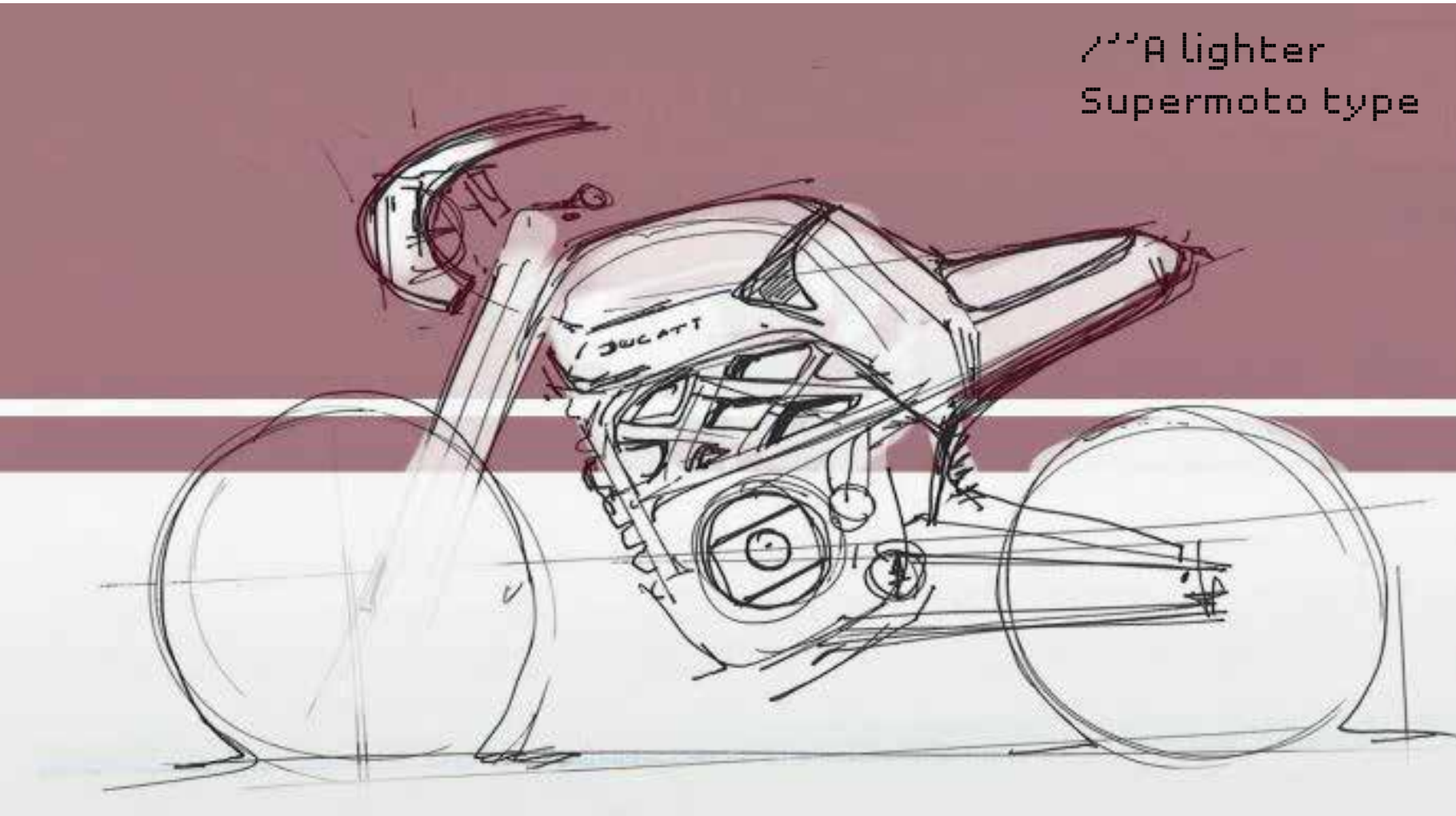

Ducati light city electric bike for 2040

packaging of a E-bike : ideation & thinking

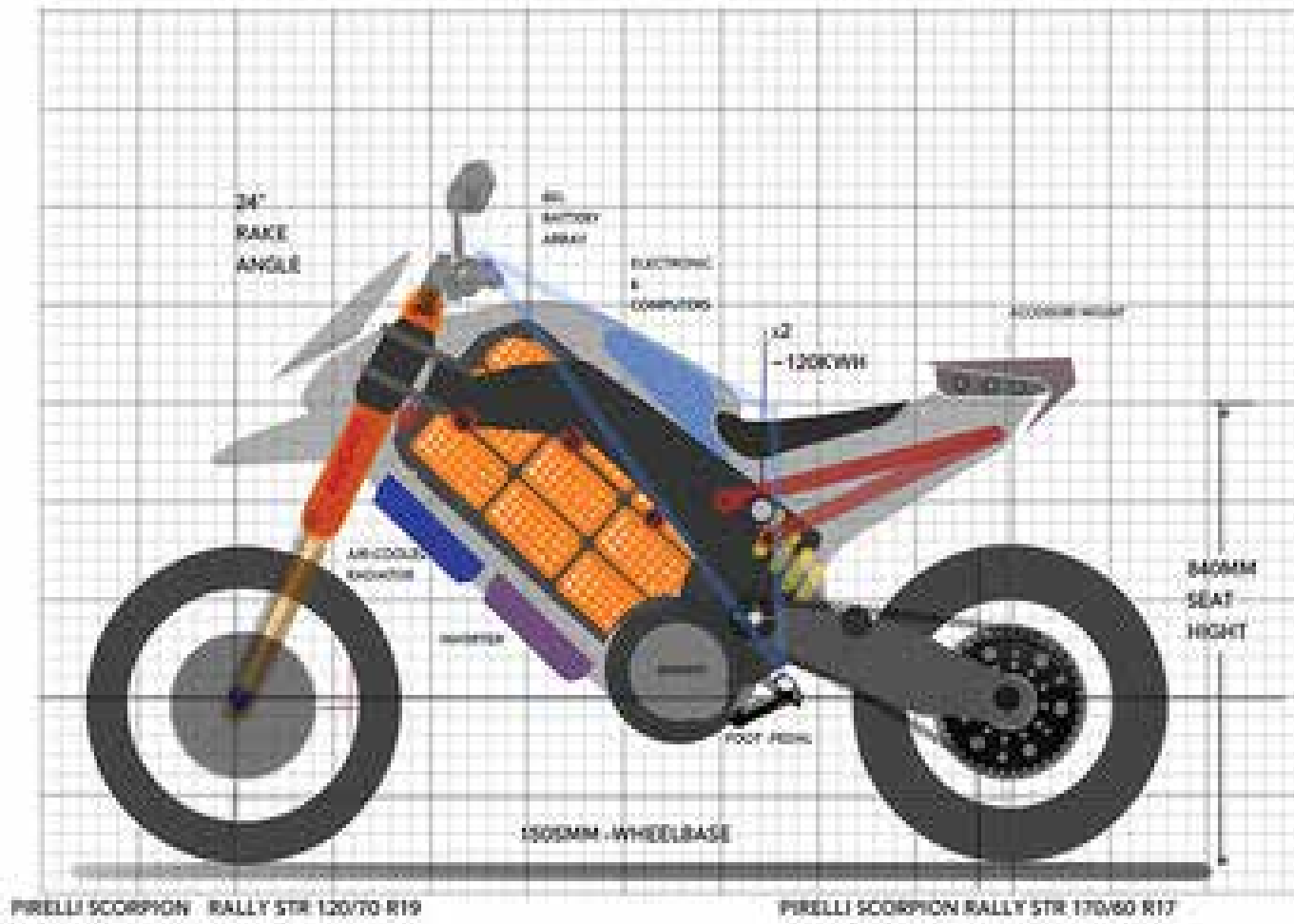
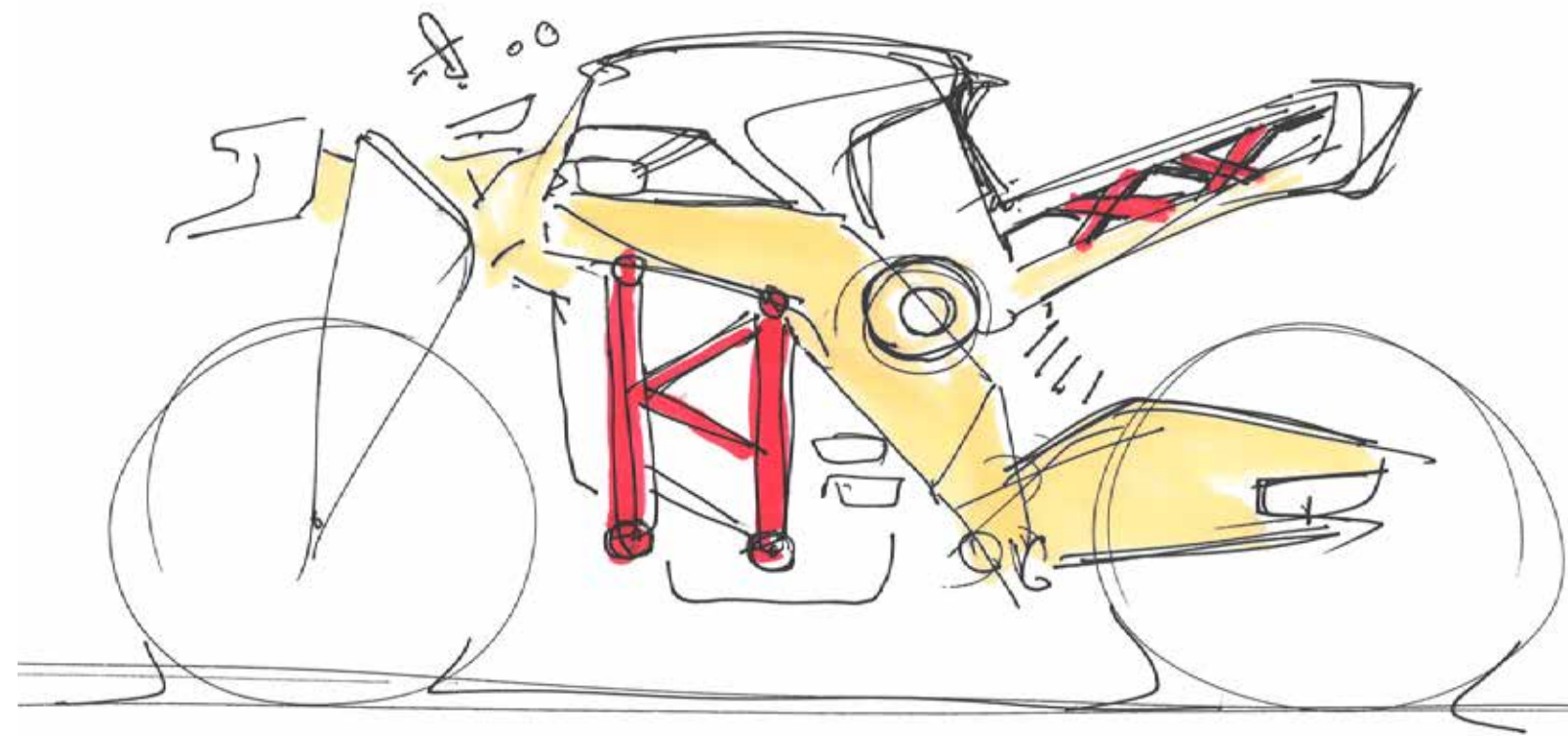

stage 2 :



balance of package
and aesthetics//

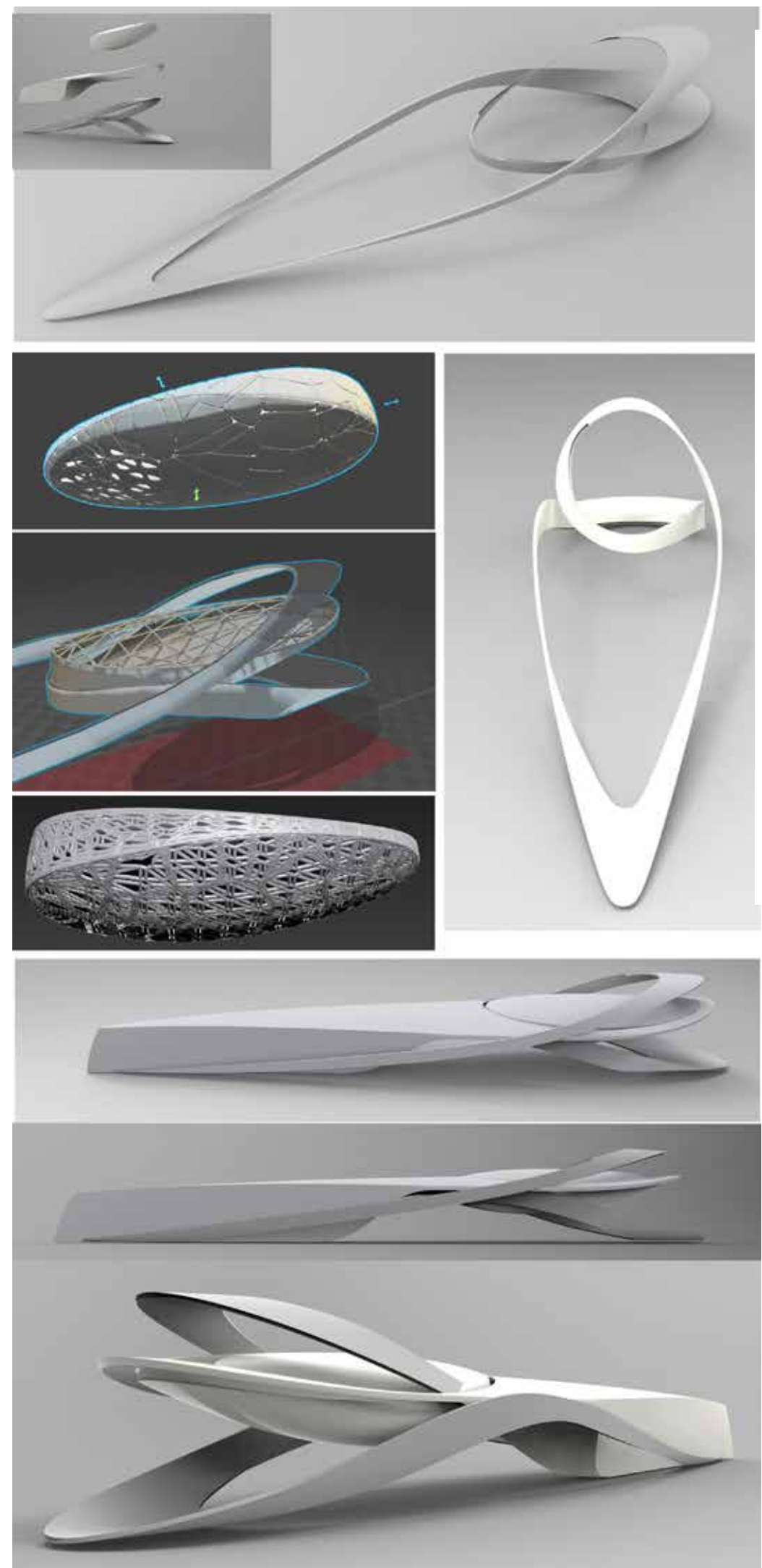
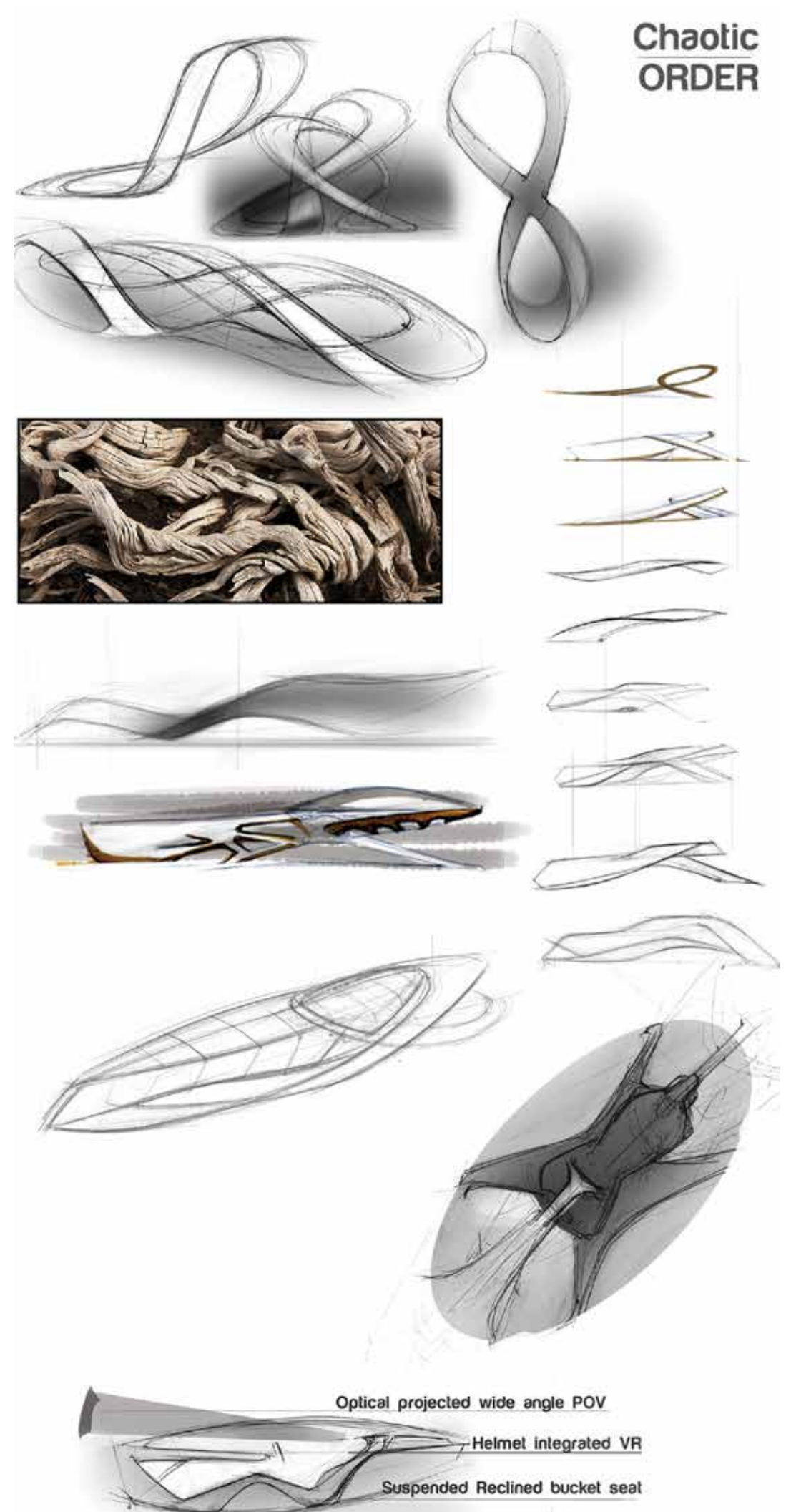

stage 3 :
 experiment with
 parametric and generated design and
 feed it back to handsketch process

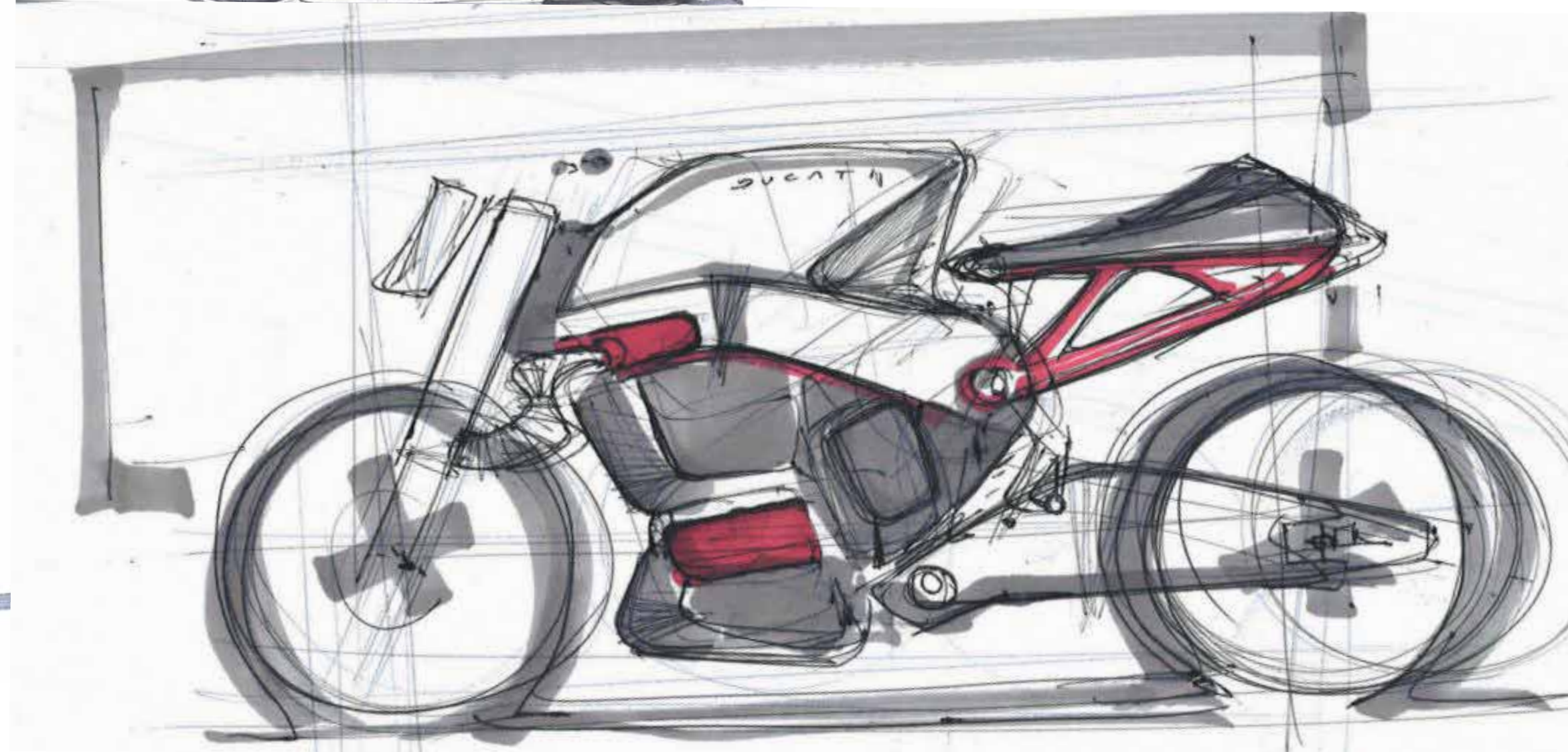
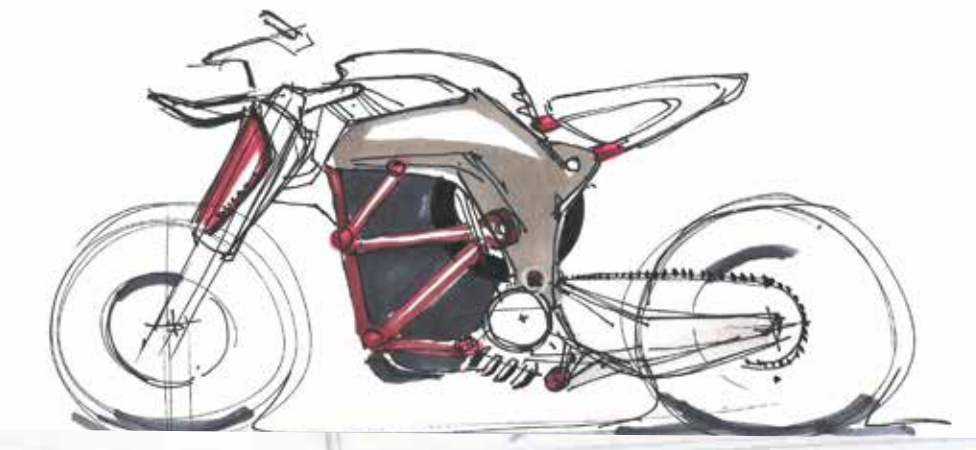
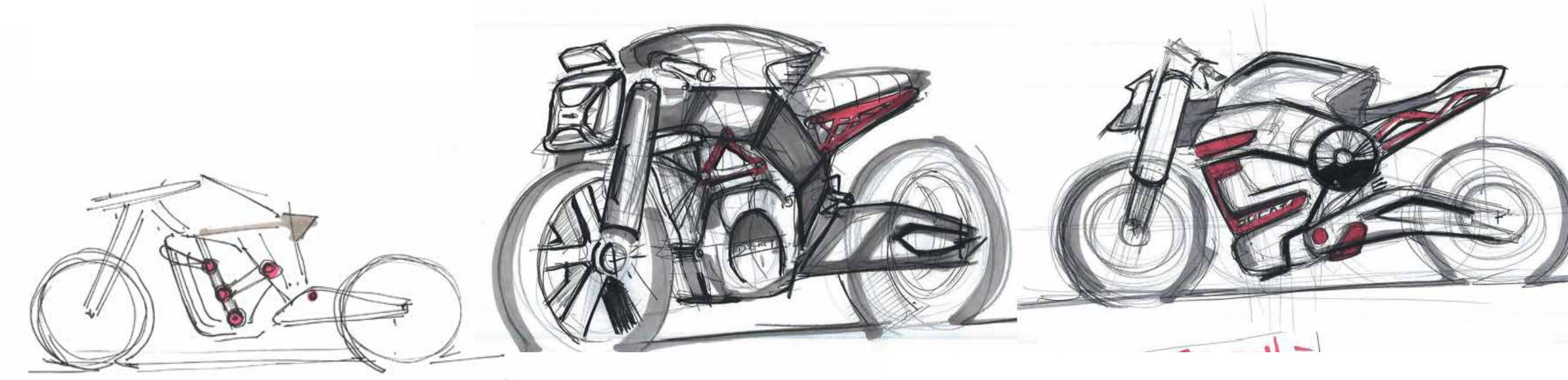
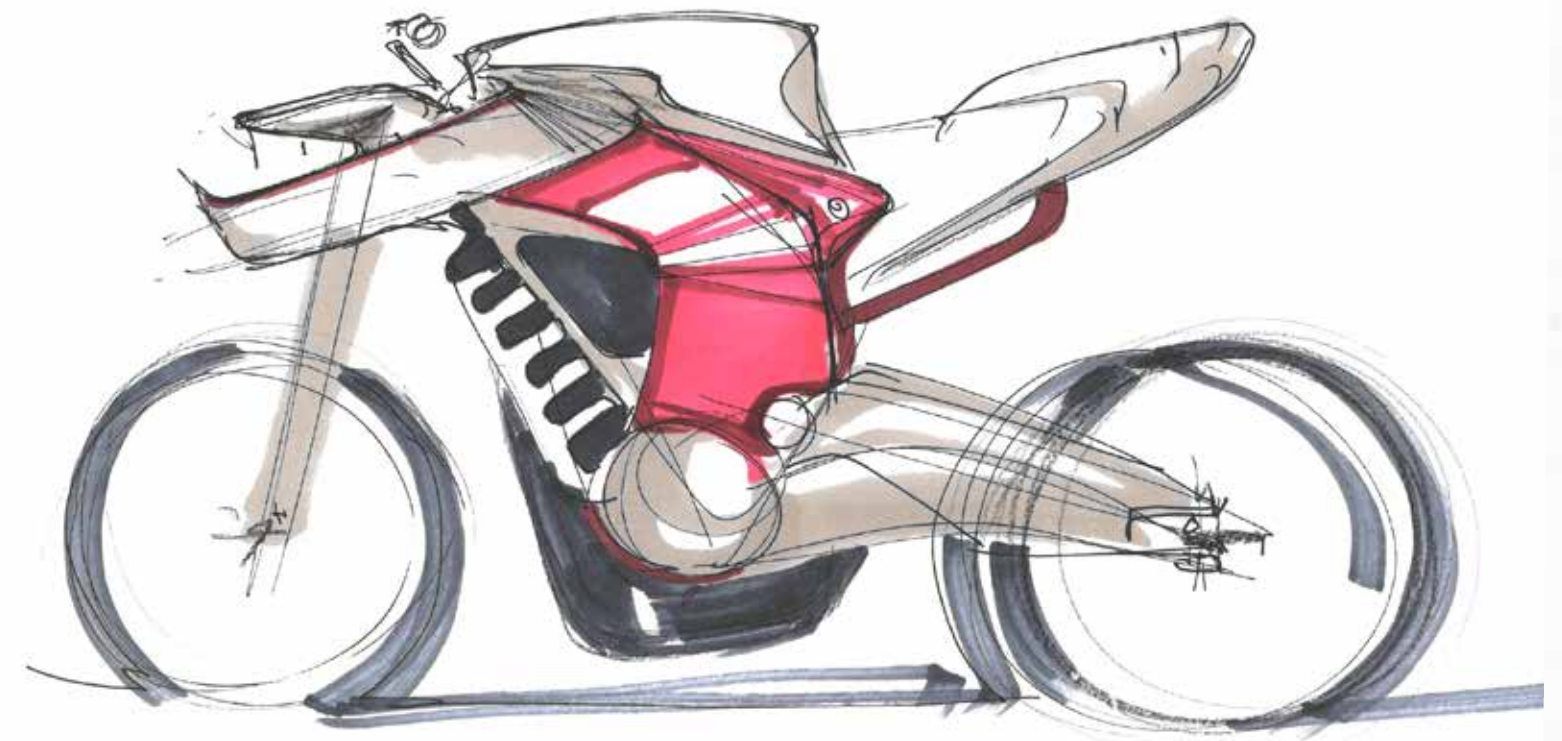
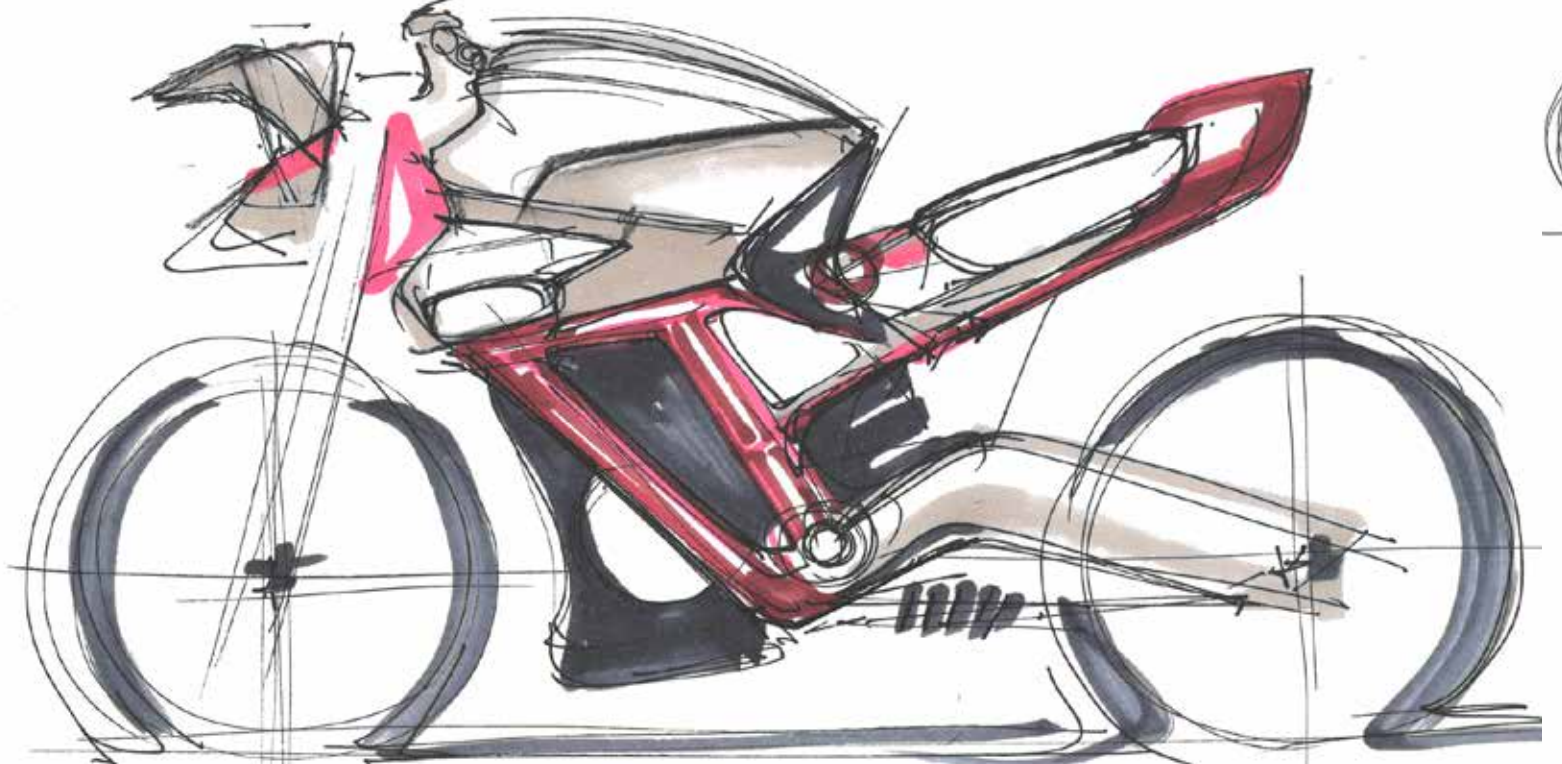

Stage 4 :

3D
CAS

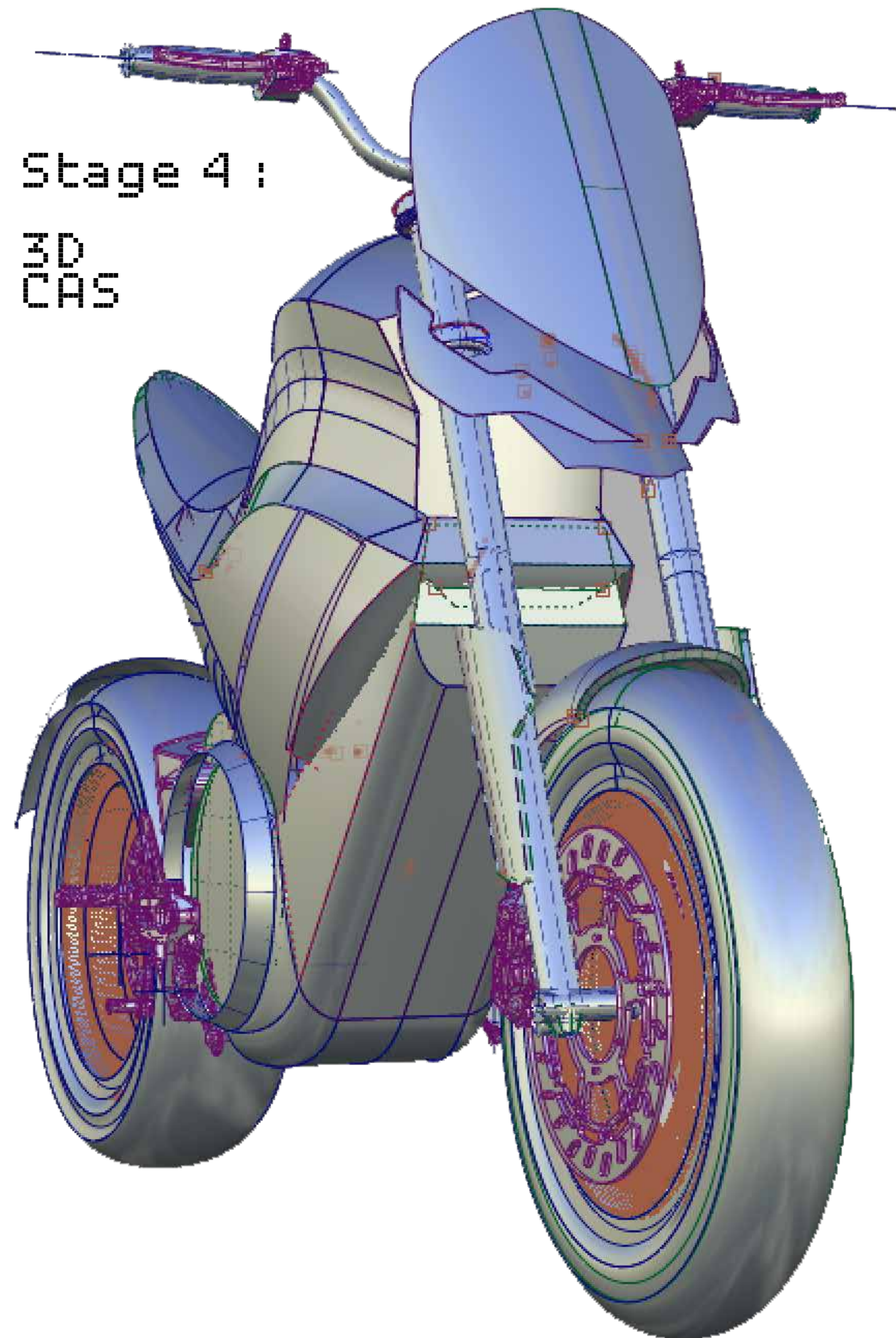

Colour Palette

1 0 95 94 28	2 69 53 46 22	3 47 73 48 67	4 0 19 79 0	5 100 0 38 2
6 4 2 4 8	7 23 16 13 46	8 40 30 20 66	9 0 0 0 94	

Exterior Colour Harmony



Stage 5 : C&T poster for material choice



- A**
 - Material :** Aluminum
 - Finishing :** Combination of satin and high gloss
 - Process:** Anodization
 - Color:** PANTONE 19-4517 TPG (69-53-46-22)
 - Accent :** PANTONE 7620 C (0 95 94 28)
- B**
 - Material:** High-density fibre polymer or high-density Hemp -
 - Finishing:** Textured hard fabric
 - Color:** PANTONE Cool Gray 10 C and 9 C (CMYK 40 30 20 66) (CMYK 0 0 0 94)
- C**
 - Material:** Aluminum and magnesium
 - Process:** Metal forge
 - Finishing:** Gloss, Power finish.
 - Color:** PANTONE 1225 C (0 19 79 0)
- D**
 - Material:** CNC Aluminum/hard plastic - Anodizing/powder coated
 - Process:** CNC milling
 - Finishing:** Anodized Matte/ powder finish.
 - Color:** PANTONE Cool Gray 8 C (CMYK 23 16 13 46)

- E**
 - Material :** Softwood and foam
 - Process :** Natural wood pressed with foam
 - Finishing :** Dark Smooth Walnut
 - Color:** PANTONE 2478 C (47 73 48 67)
- F**
 - Material:** Aluminium sintered powder
 - Process:** Additive manufacturing
 - Finishing:** Raw sintering finishing
 - Color:** PANTONE Cool Gray 8 C (23 16 13 46)
- G**
 - Material :** Hard ABS Plastic
 - Process:** Injection Moulding
 - Finishing:** Gloss
 - Color:** PANTONE Cool Gray 1 C (4 2 4 8)
- H**
 - Material :** Coring glass
 - Finishing :** Gloss
 - Color:** PANTONE Cool Gray 10 C (40 30 20 66)
- I**
 - Material :** Translucent Film
 - Finishing :** Translucent gloss
 - Color:** PANTONE 19-4517 TPG (100 0 38 2)

Stage 6: PREP for A- class surfacing



/cluster design

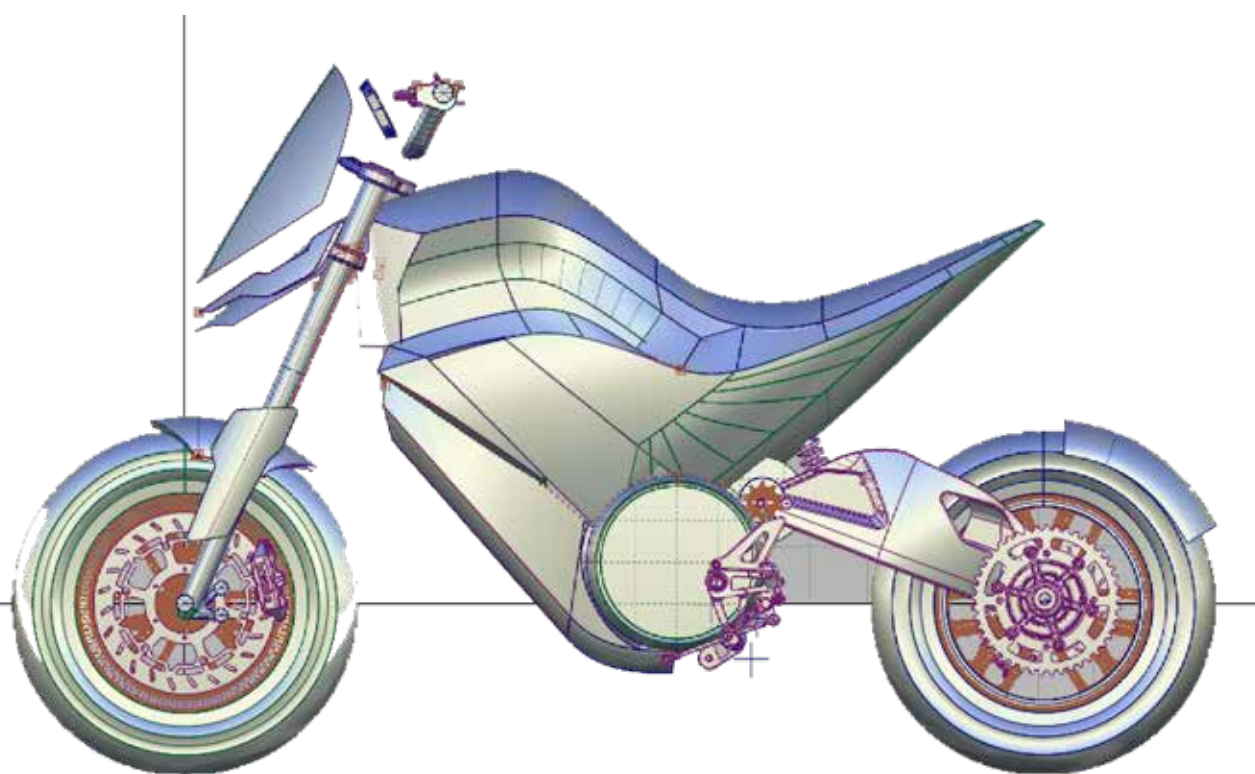

\emotional renders .



Other experiments
and sectional
analysis & thinking

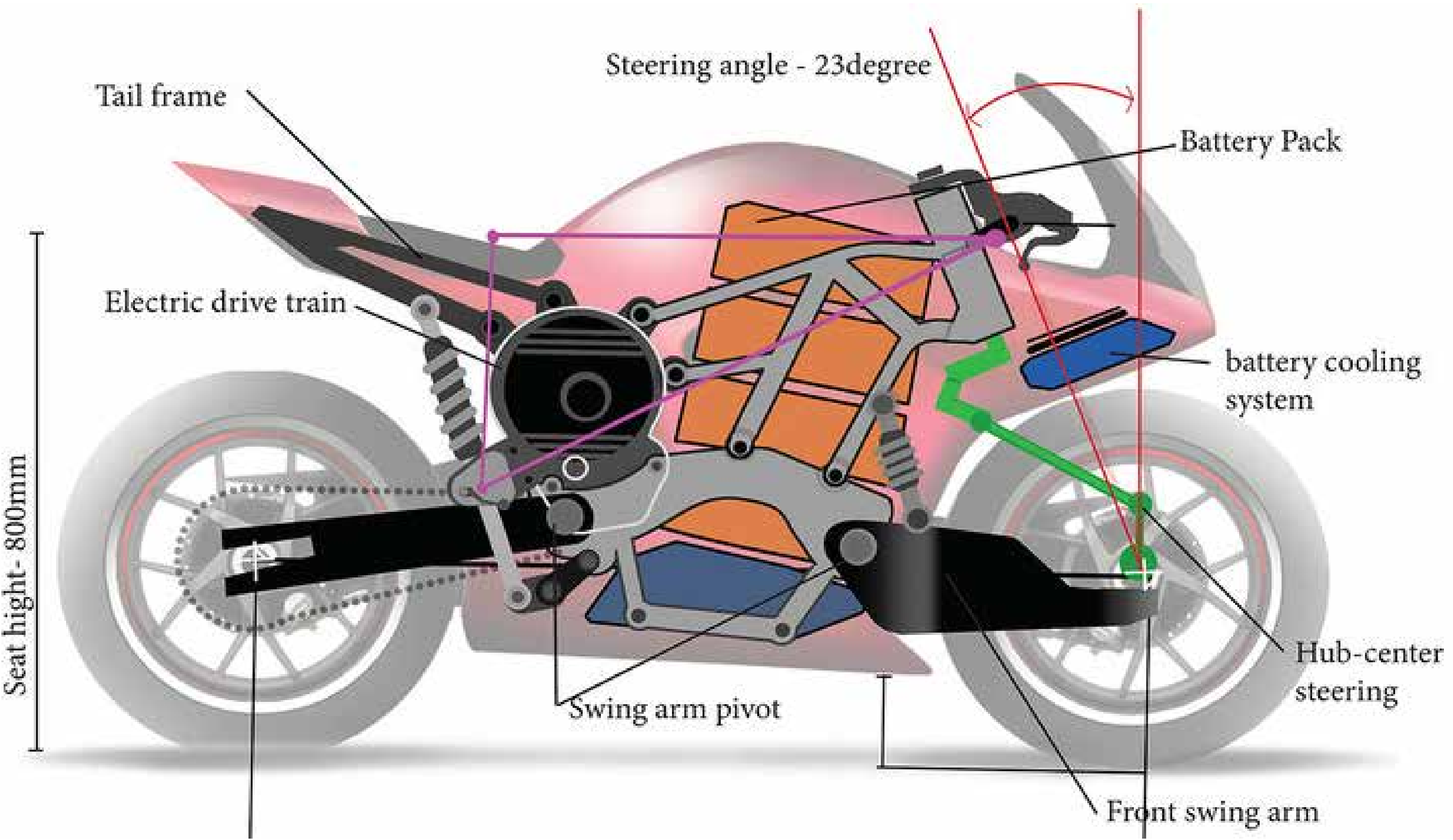

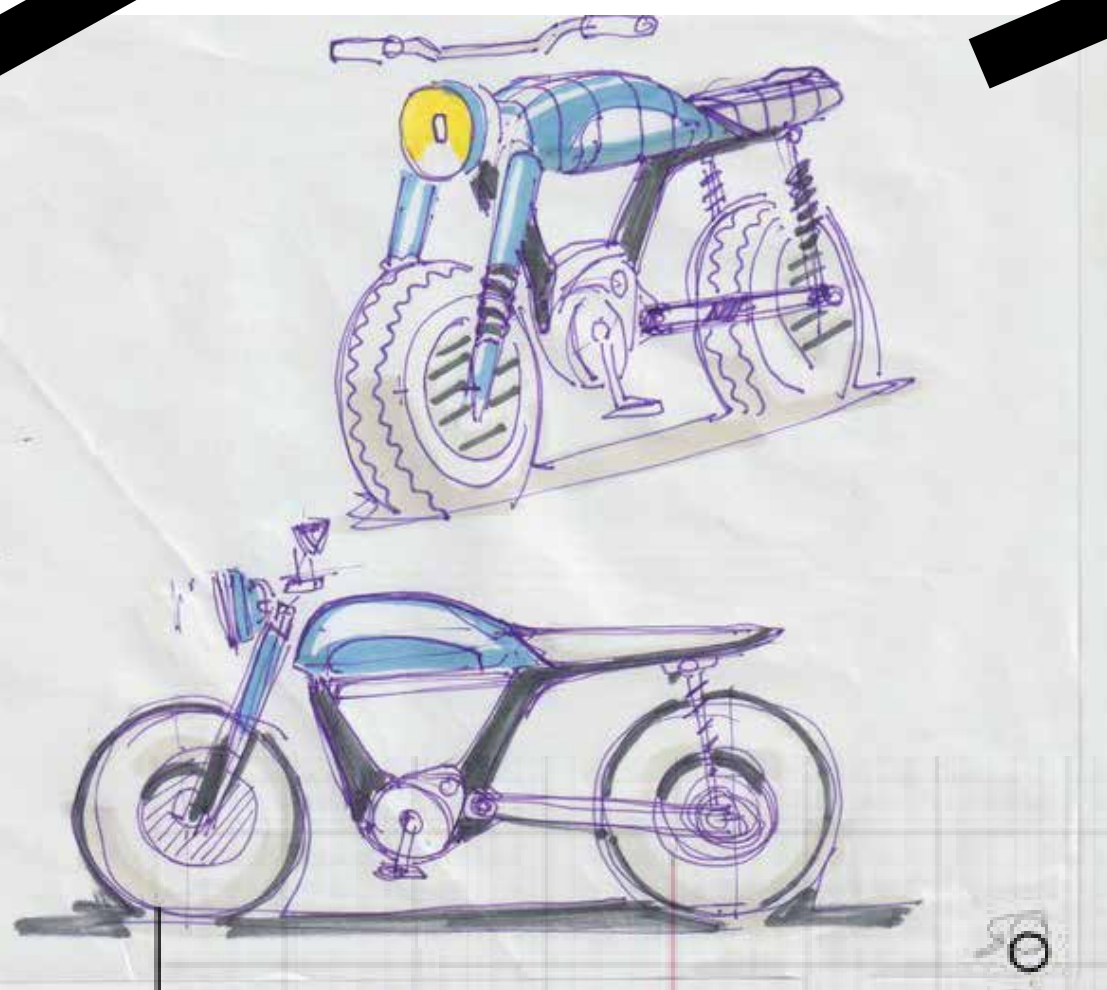

other quick project :
Keysketch to Ured

An ebike for indian
cities

A Ebike made with
off-the shelf
components.

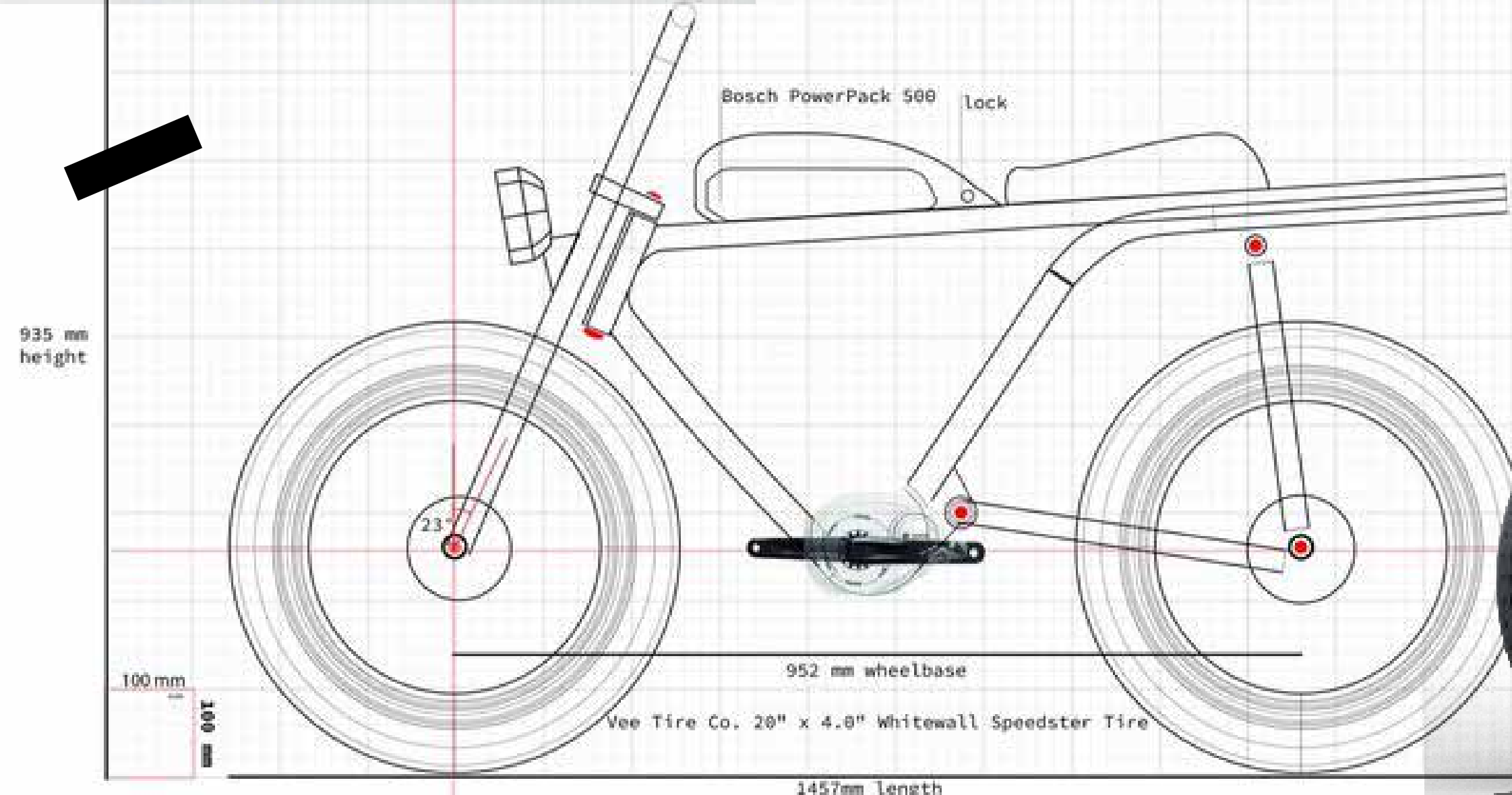
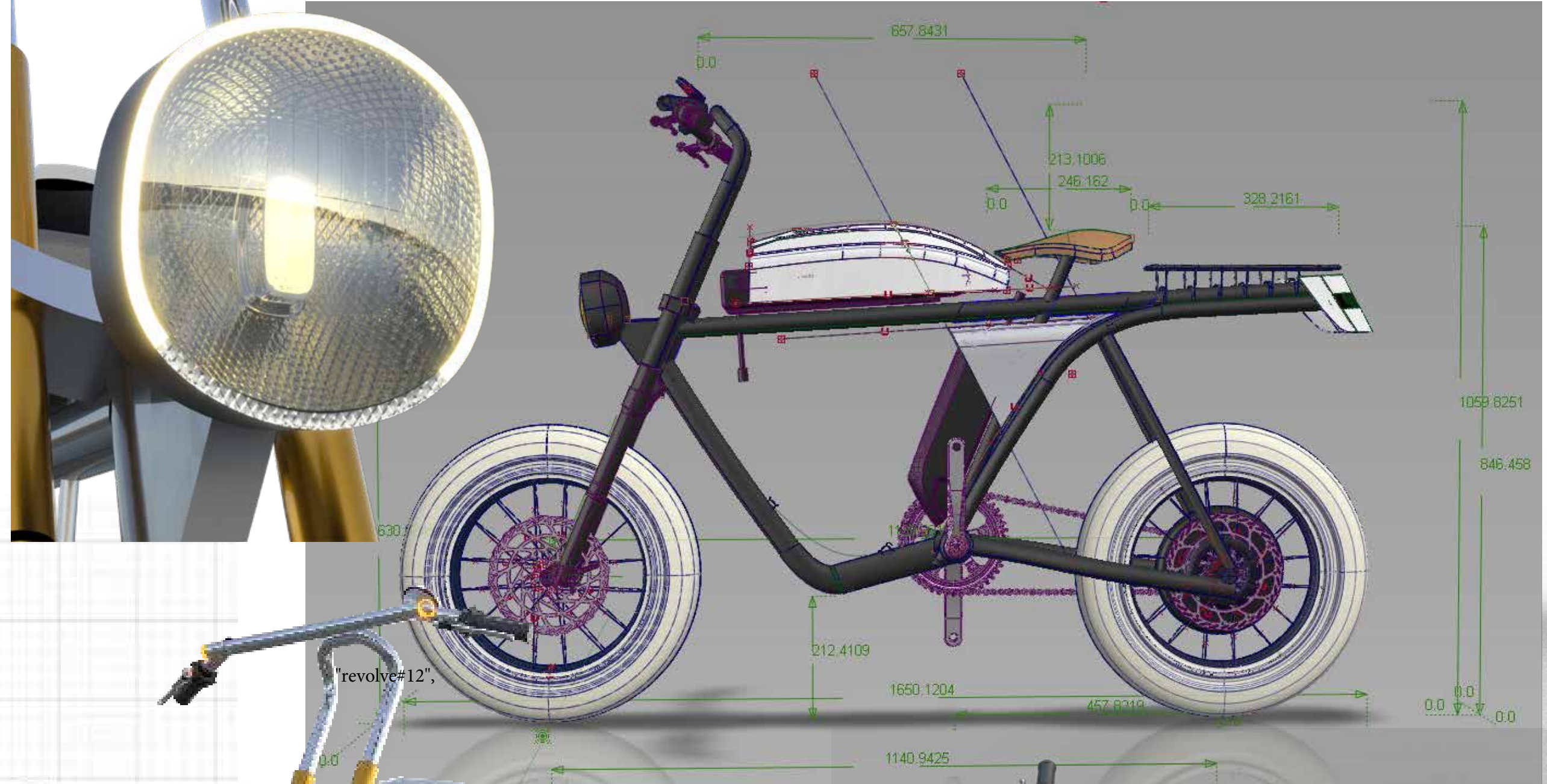



A startup in bengaluru, india
using engineering CAD
data and
Autodesk vred
Images were
rendered for the
company website

<https://e-mobify.com/>

coming soon..









\#skills

Miscellaneous

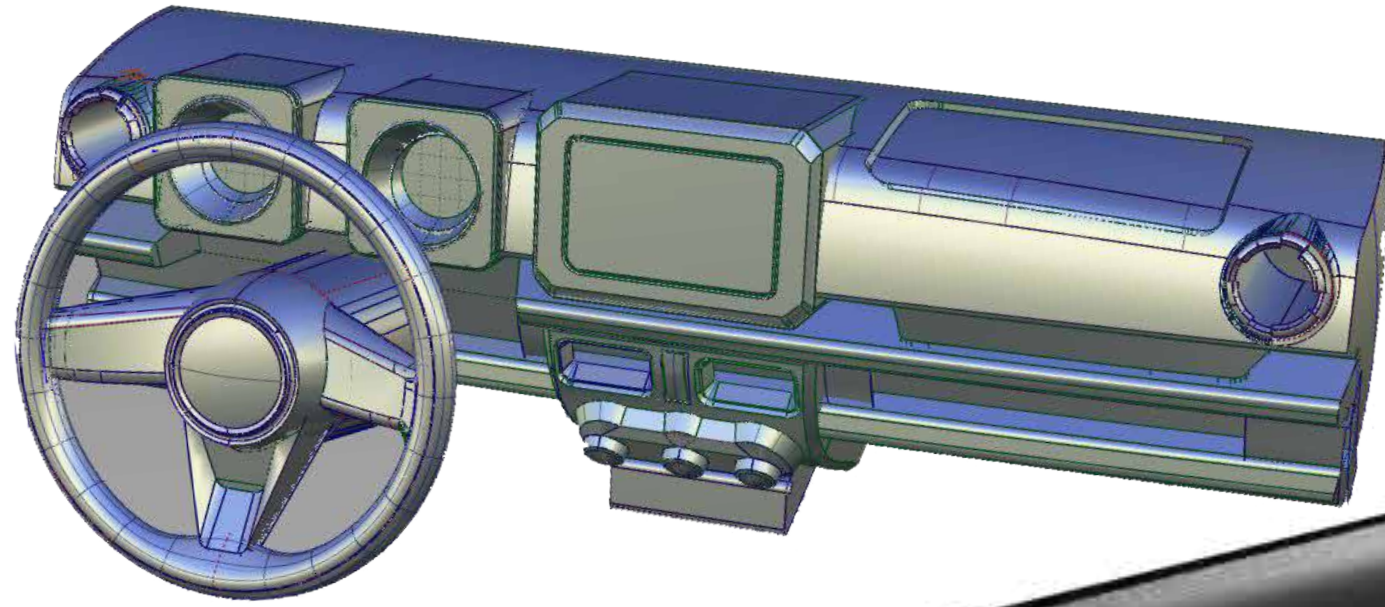

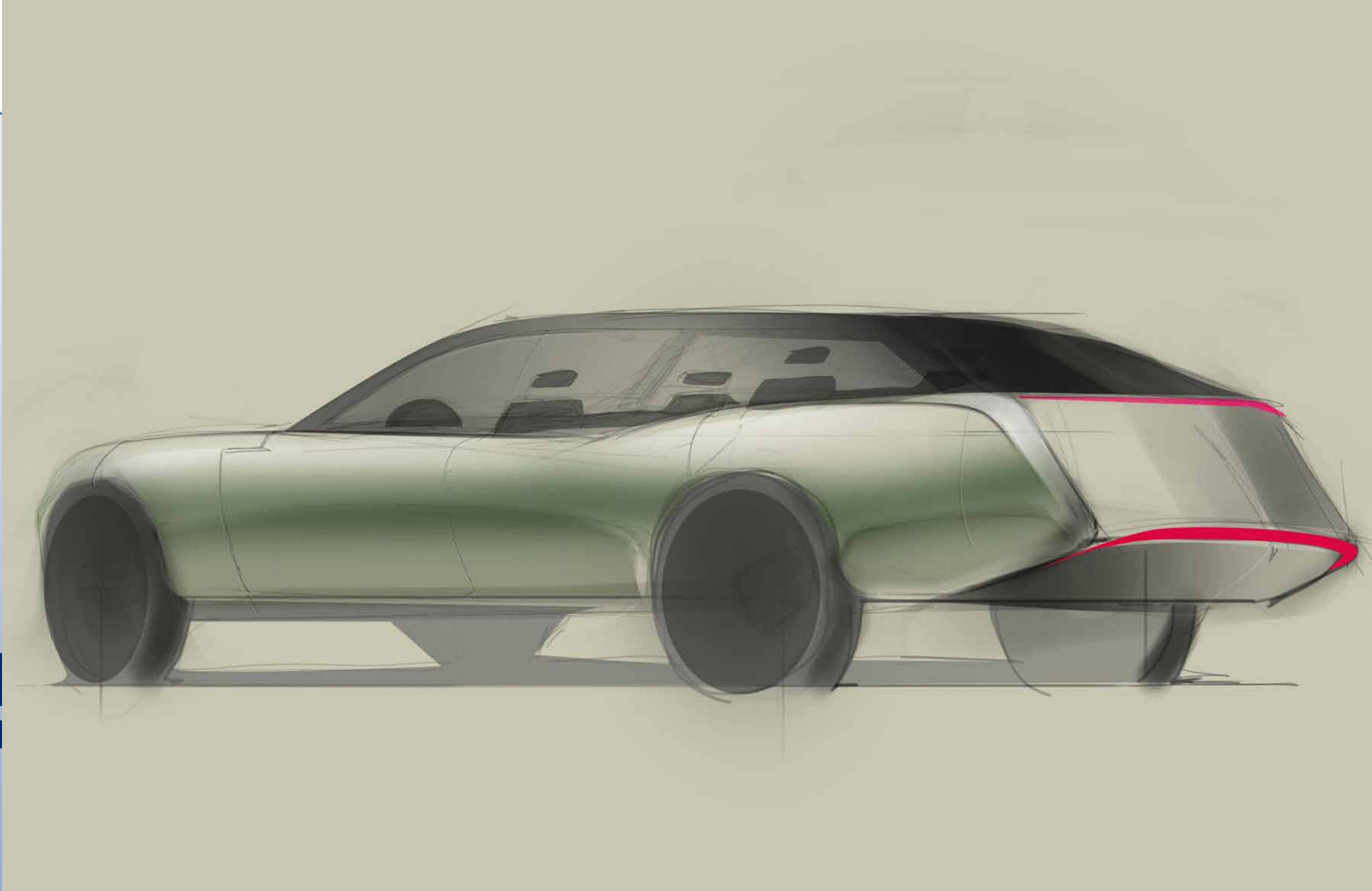



Homage :
tvs glod :
A
Retro
Mechanical
Keyboard

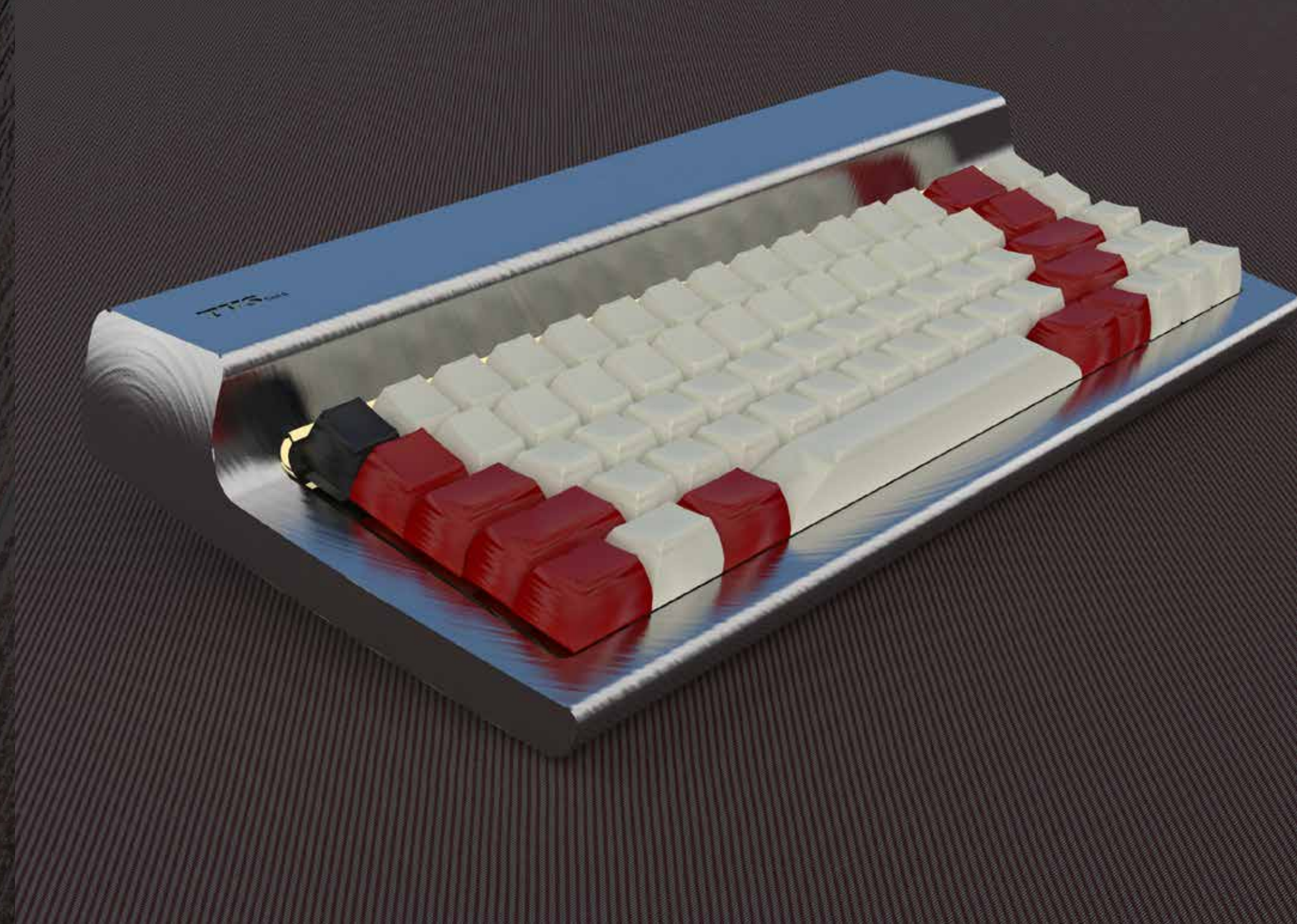
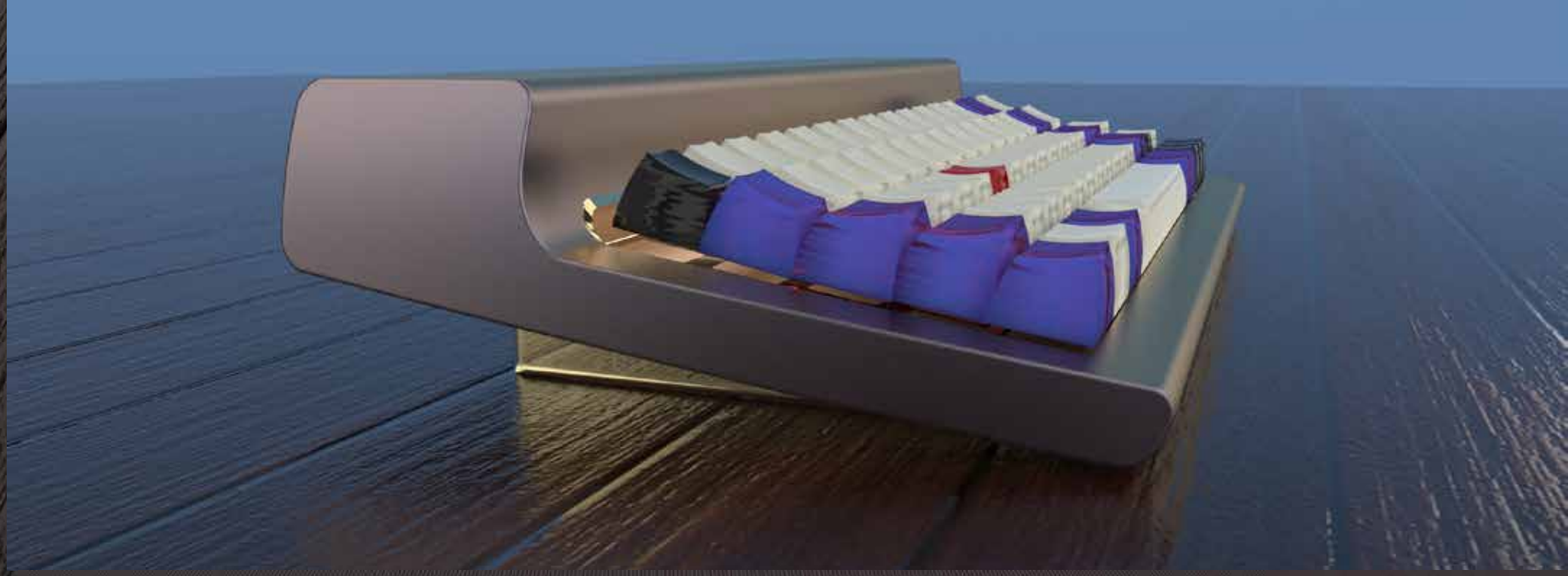



Polestar Sonett-4

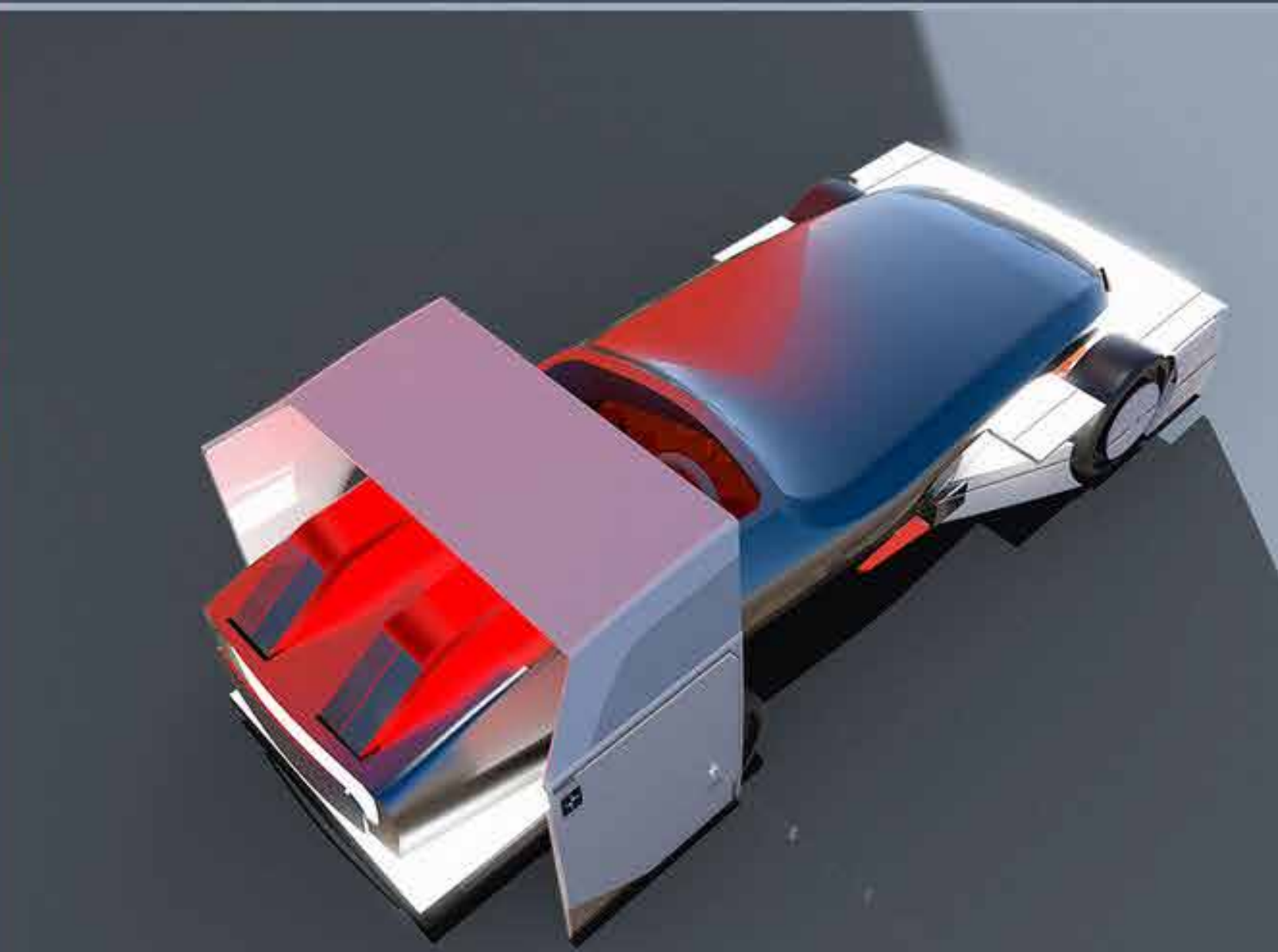
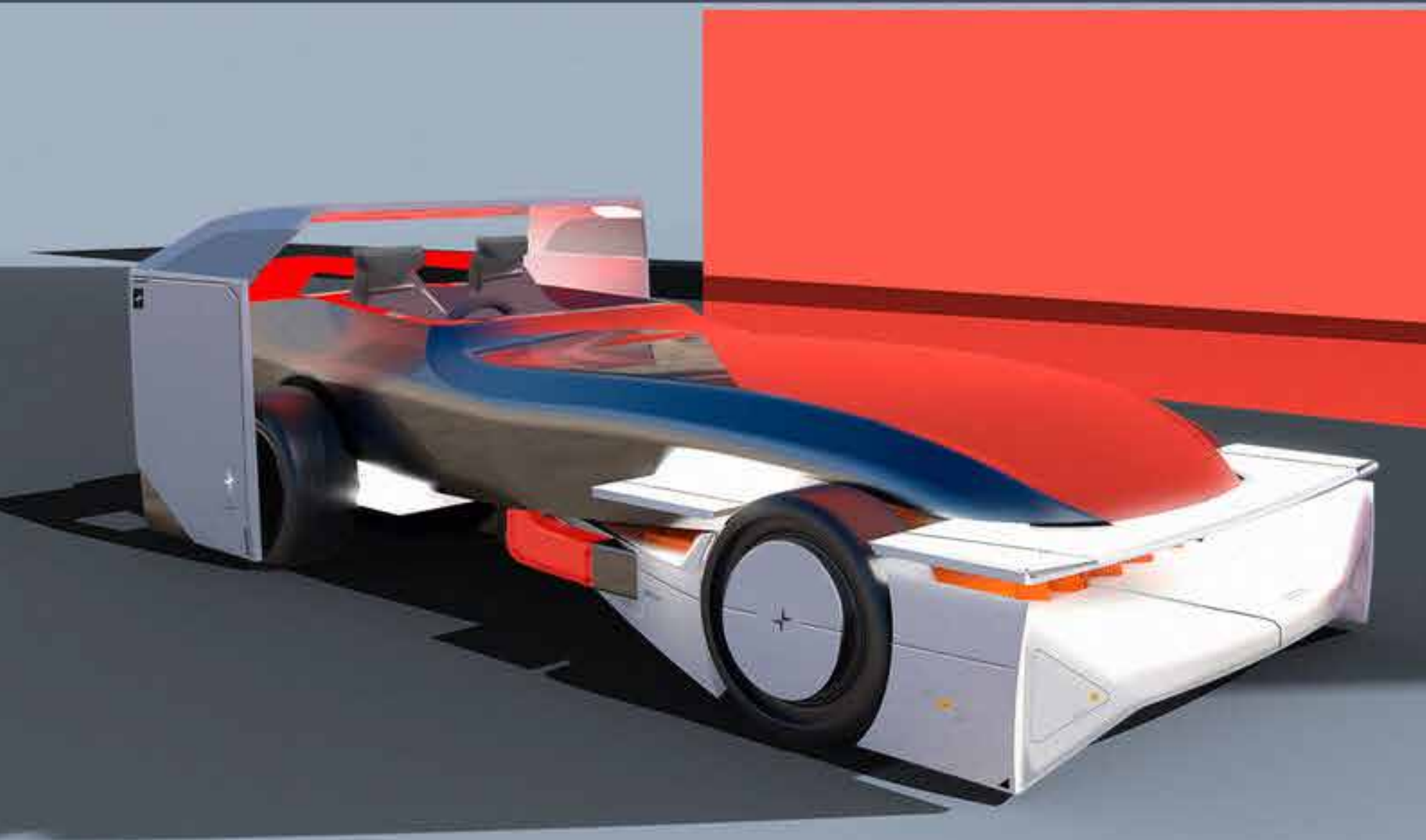

Square

A pure expression of a ridge shape is a clean square. Scandinavian design principle. A feeling of openness to light.



Contrast

White b/w Black represents square b/w curves. White towards the future and black to the past.

Connected Emphasized by Polestar accent colors



Engulfed by Light

play of Diffracted light and faces of a square. Invokes a sense of the car to the environment.

- In White.

Ambient diffused light shoots in all directions.

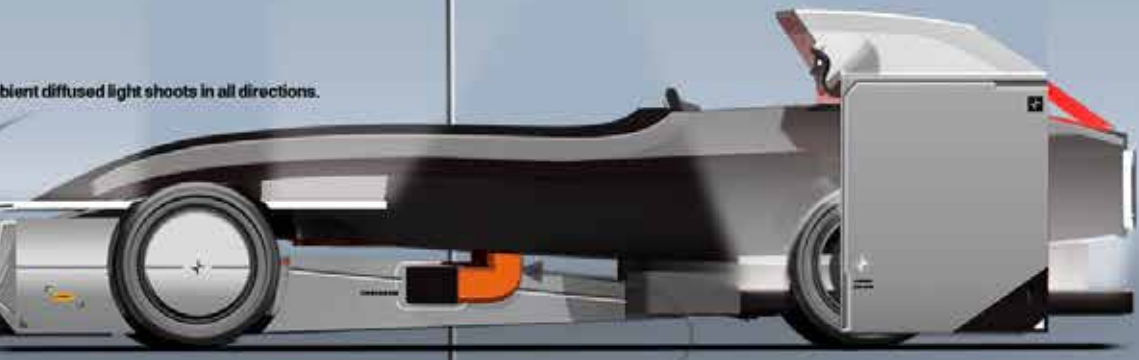

Connect the capsule here

Elegance by sensuality

Curves inspired by p1800, encapsulating the driver. A Pure form balances its edgy counter-form.

- In Black.

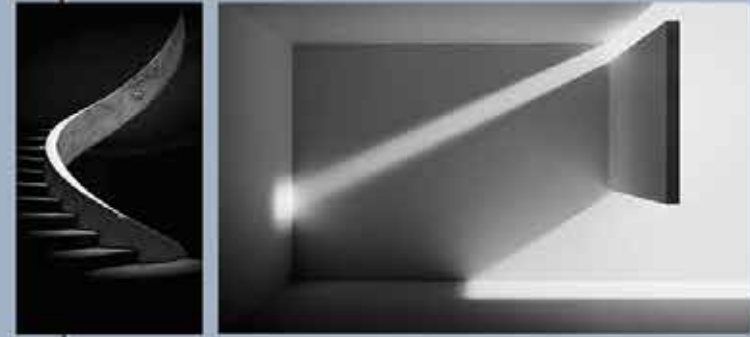

Polestar Sonett-4



Vintage

Curves on Volvo P1800 hints to the golden era for automobiles.

The year 2040 pays Homage to a fallen Scandinavian legend. The Saab Sonett I.

The brand Polestar can revive fallen brothers, by adapting its architecture to a new philosophy

-Homage



1 Semi truck for Mach motors

User need and Package study :
Work / home
Open spaces
Neo-vintage

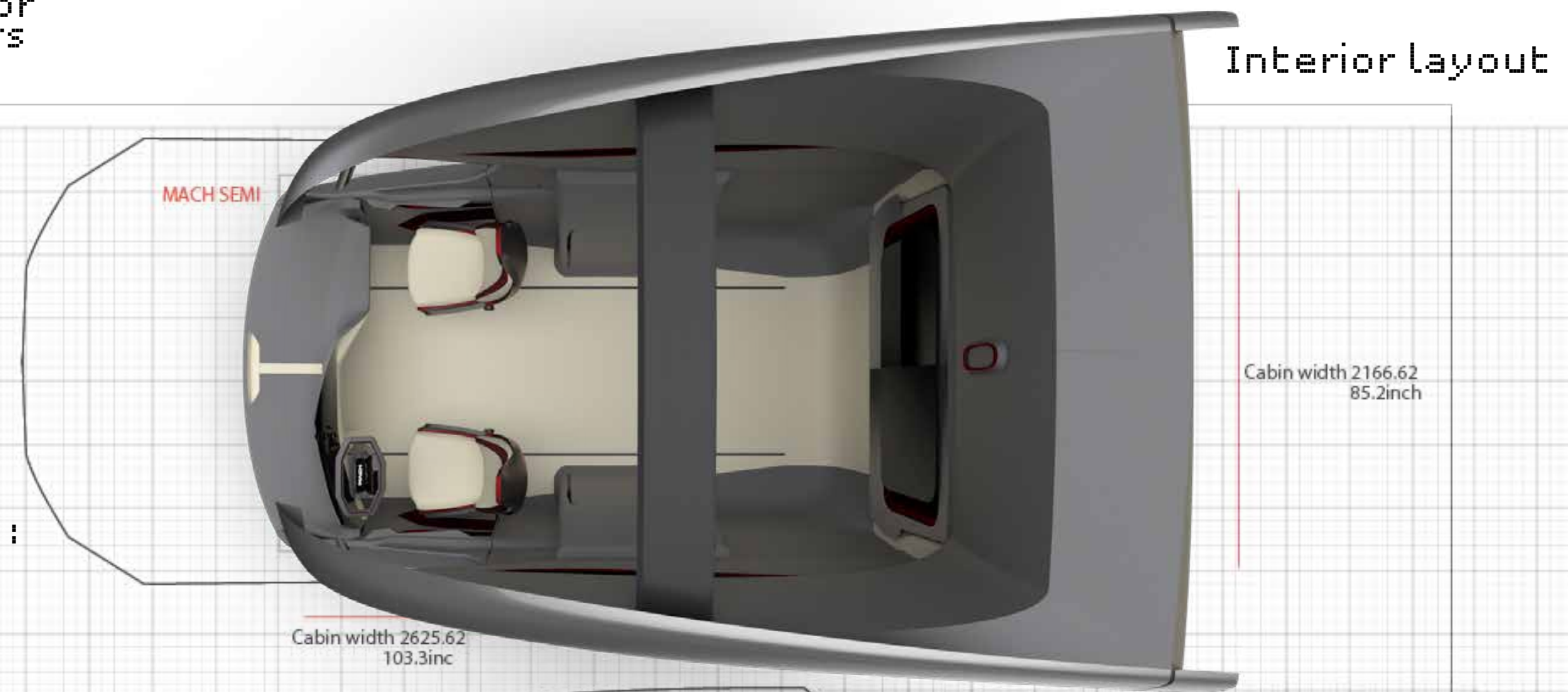

Interior layout

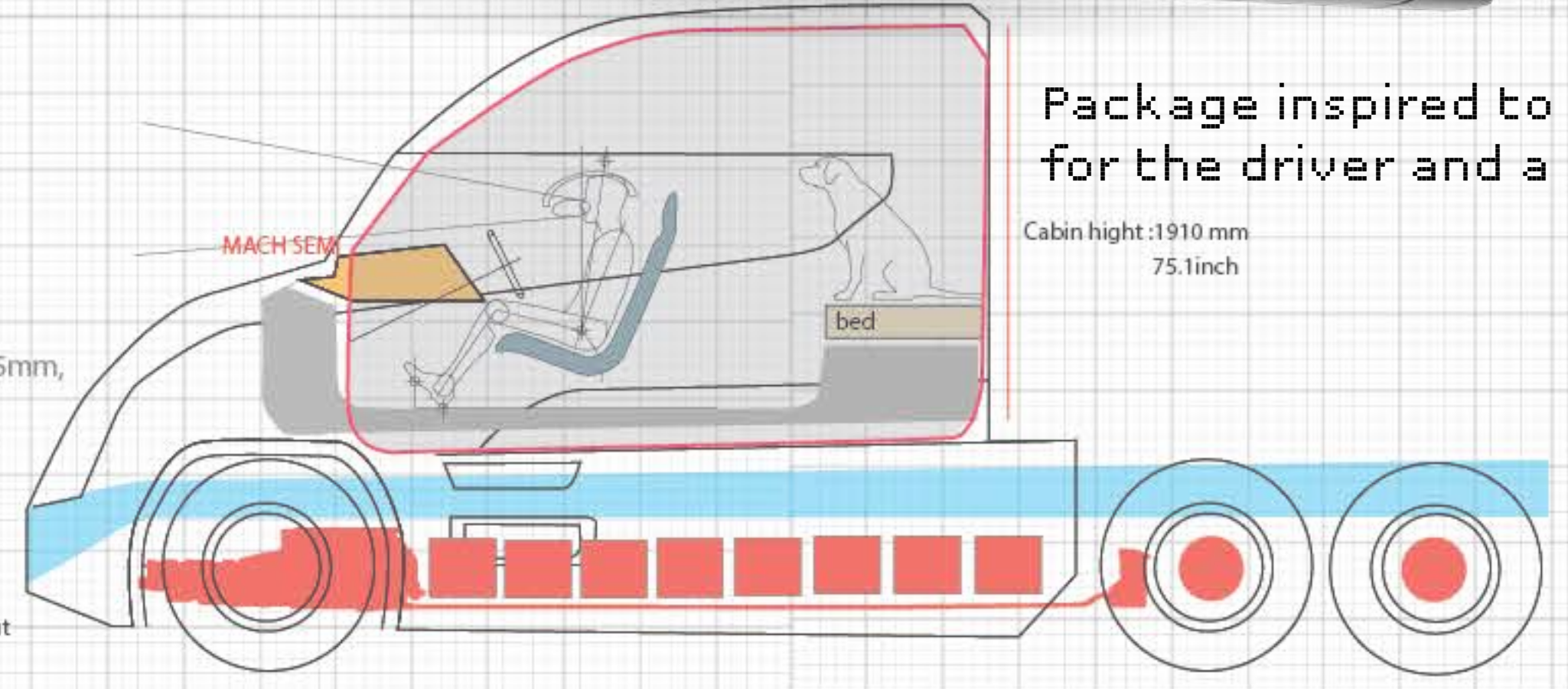

Package inspired to call home for the driver and a dog.



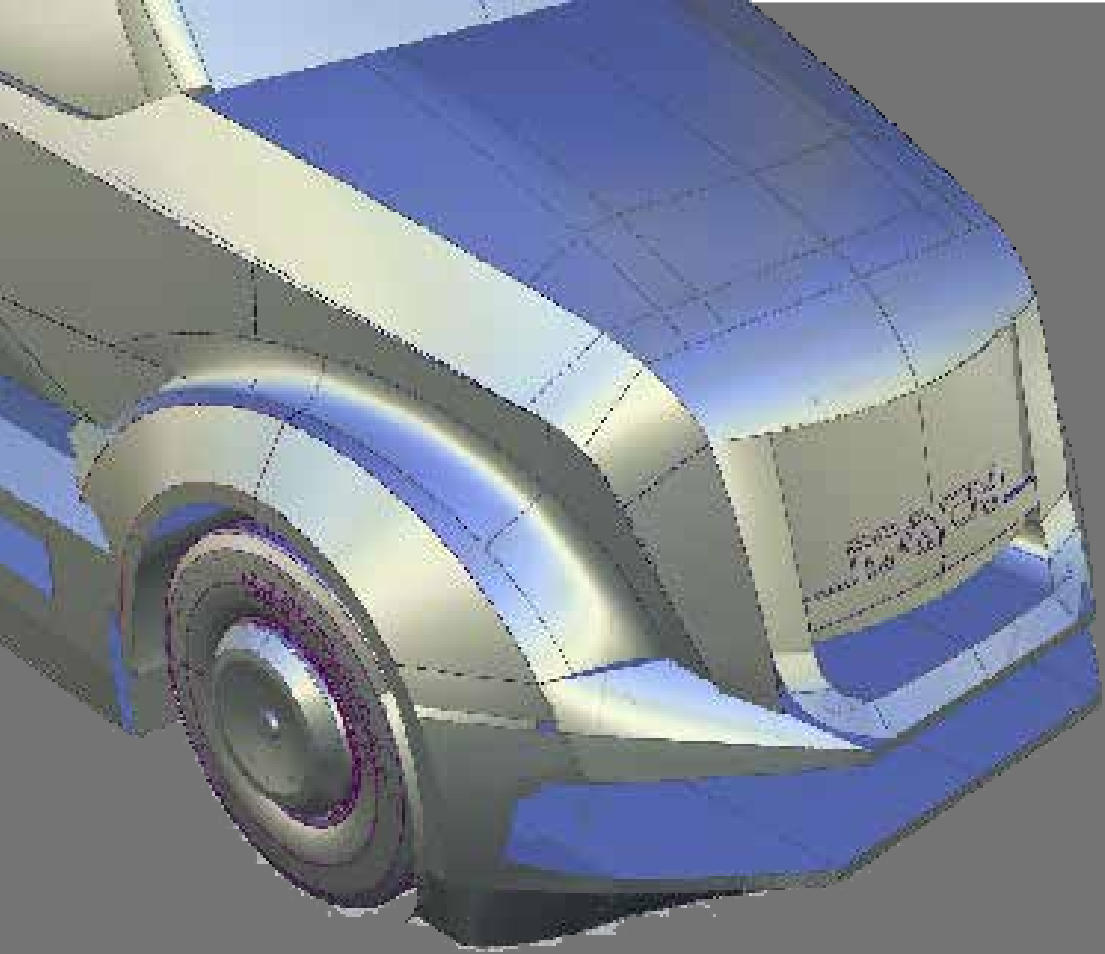

// patch layout

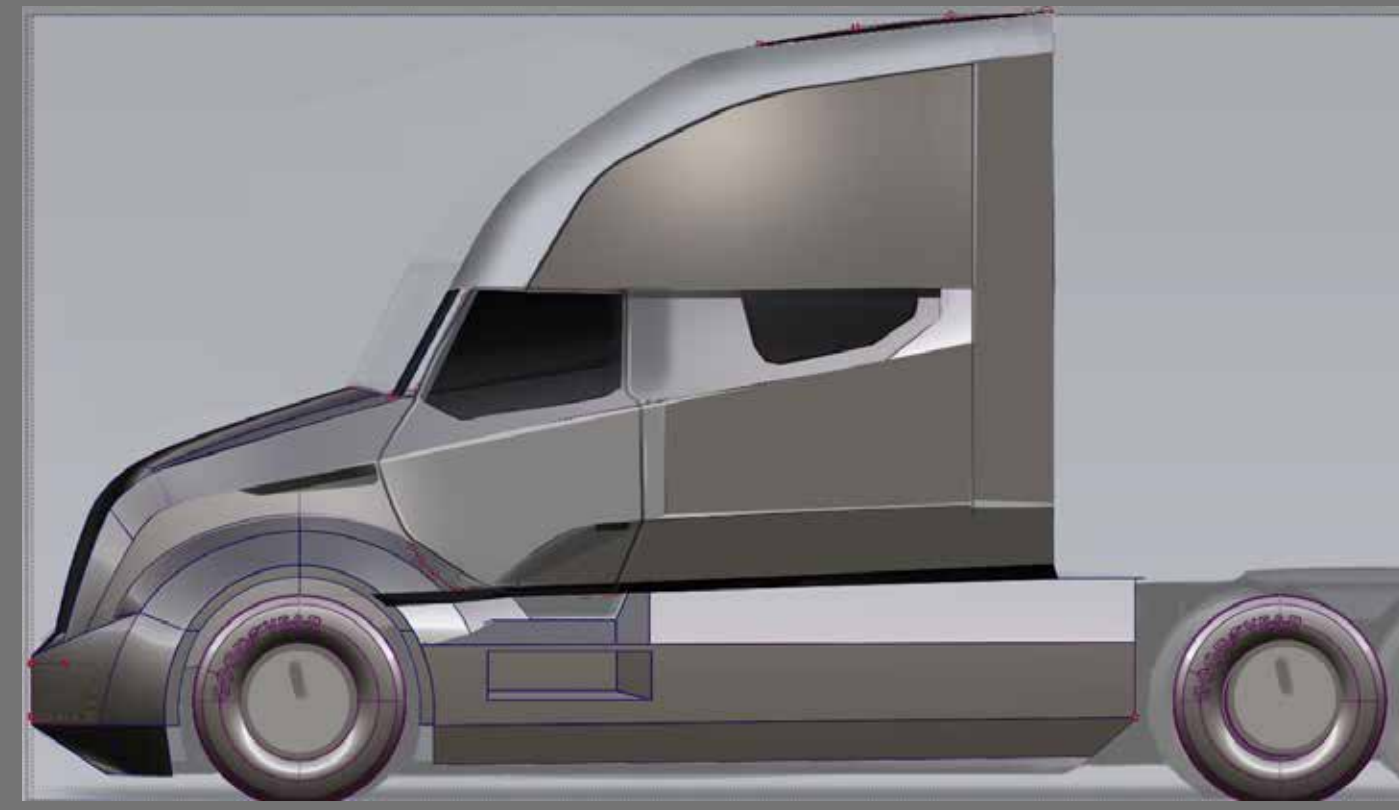

// combination of Autodesk Alias and Adobe photoshop

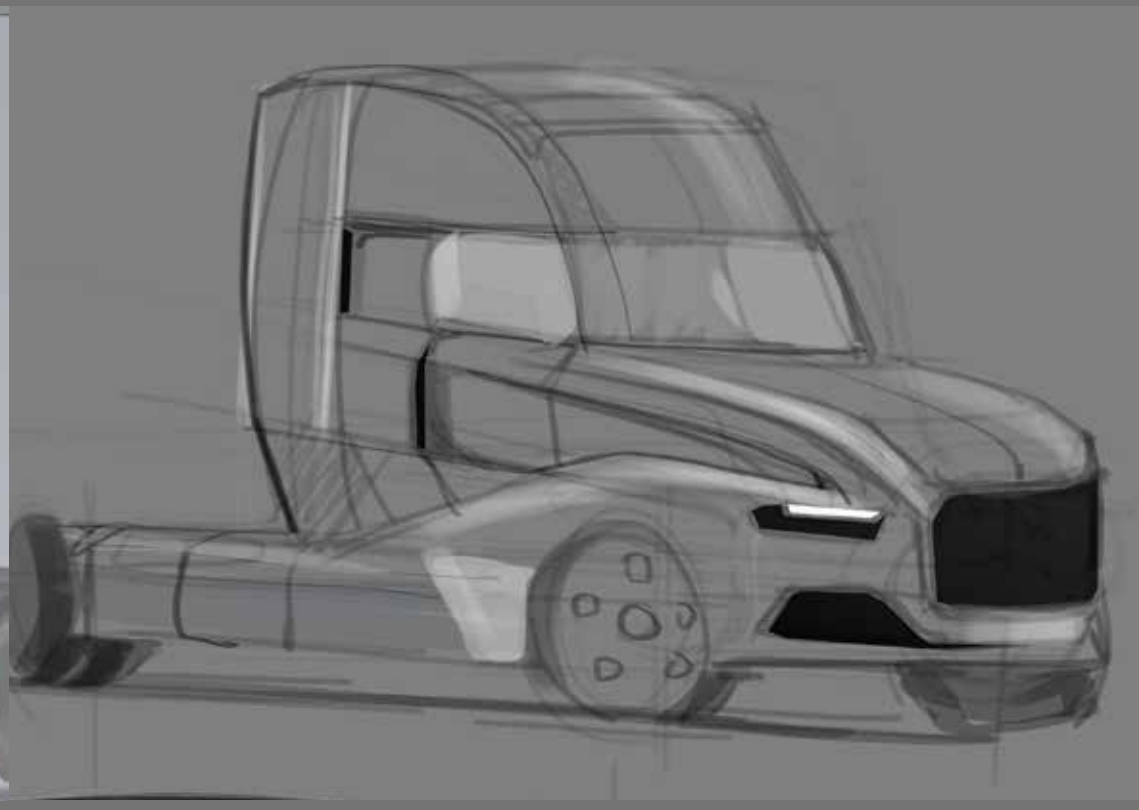

// Emotional sketch

A fast Technique for surface helped to achieve quick shapes, This project was based on a scan of a **Peterbilt 789** truck. images below are pre-fileted This project is for a new startup brand called **Mach Motors** for the American market for 2025.

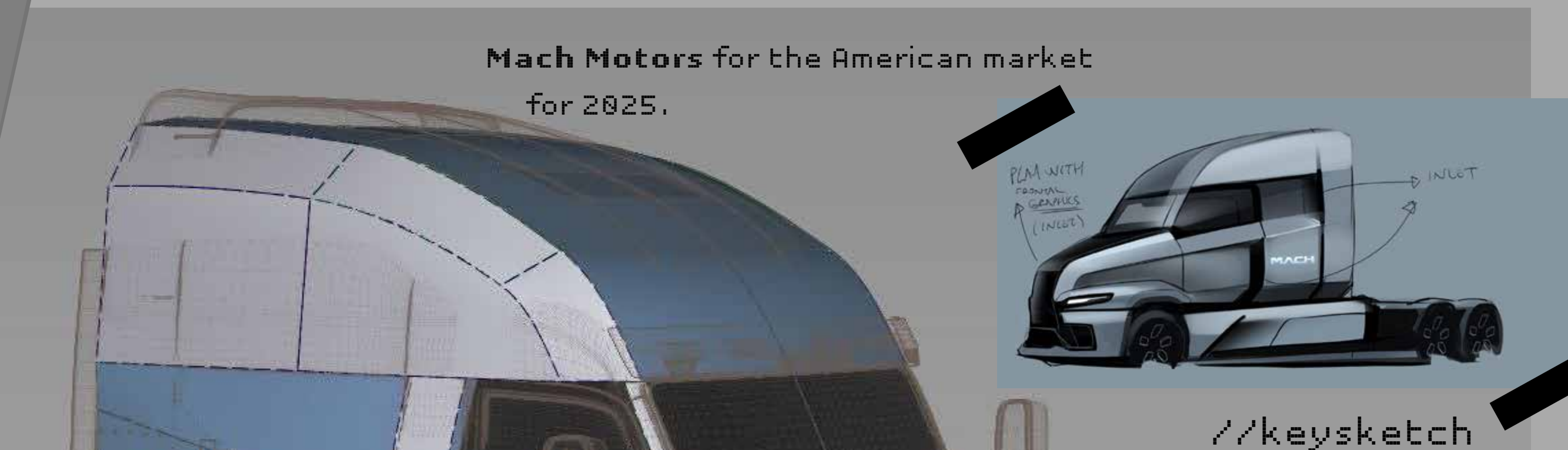

// key sketch

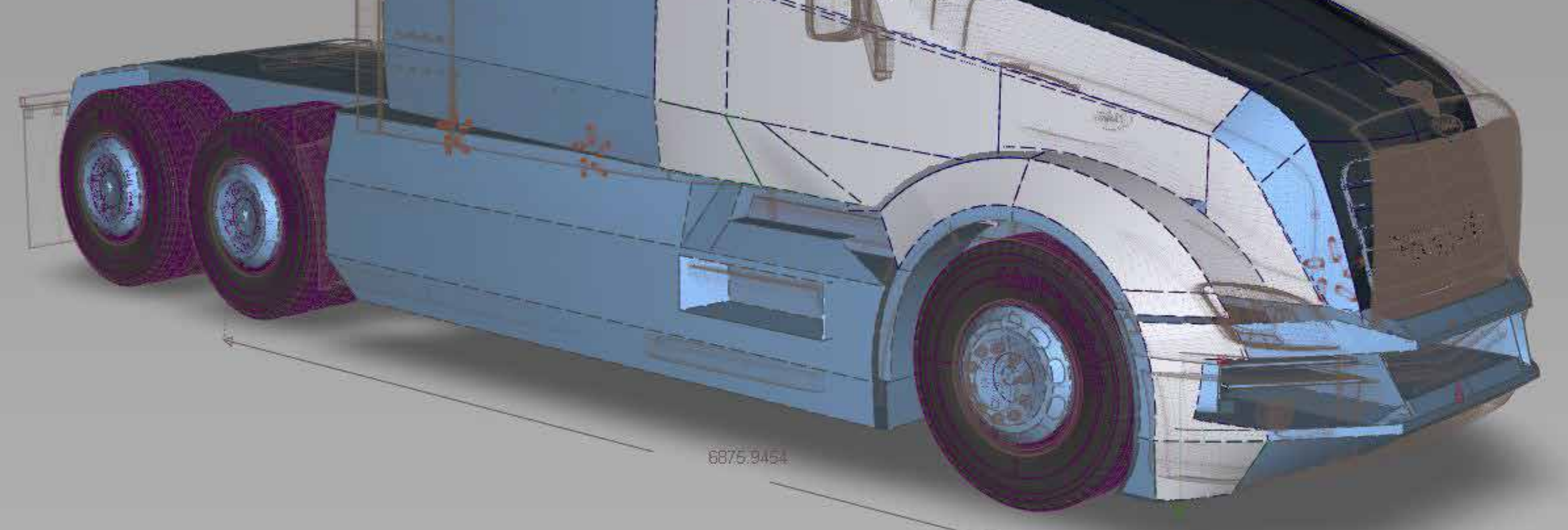
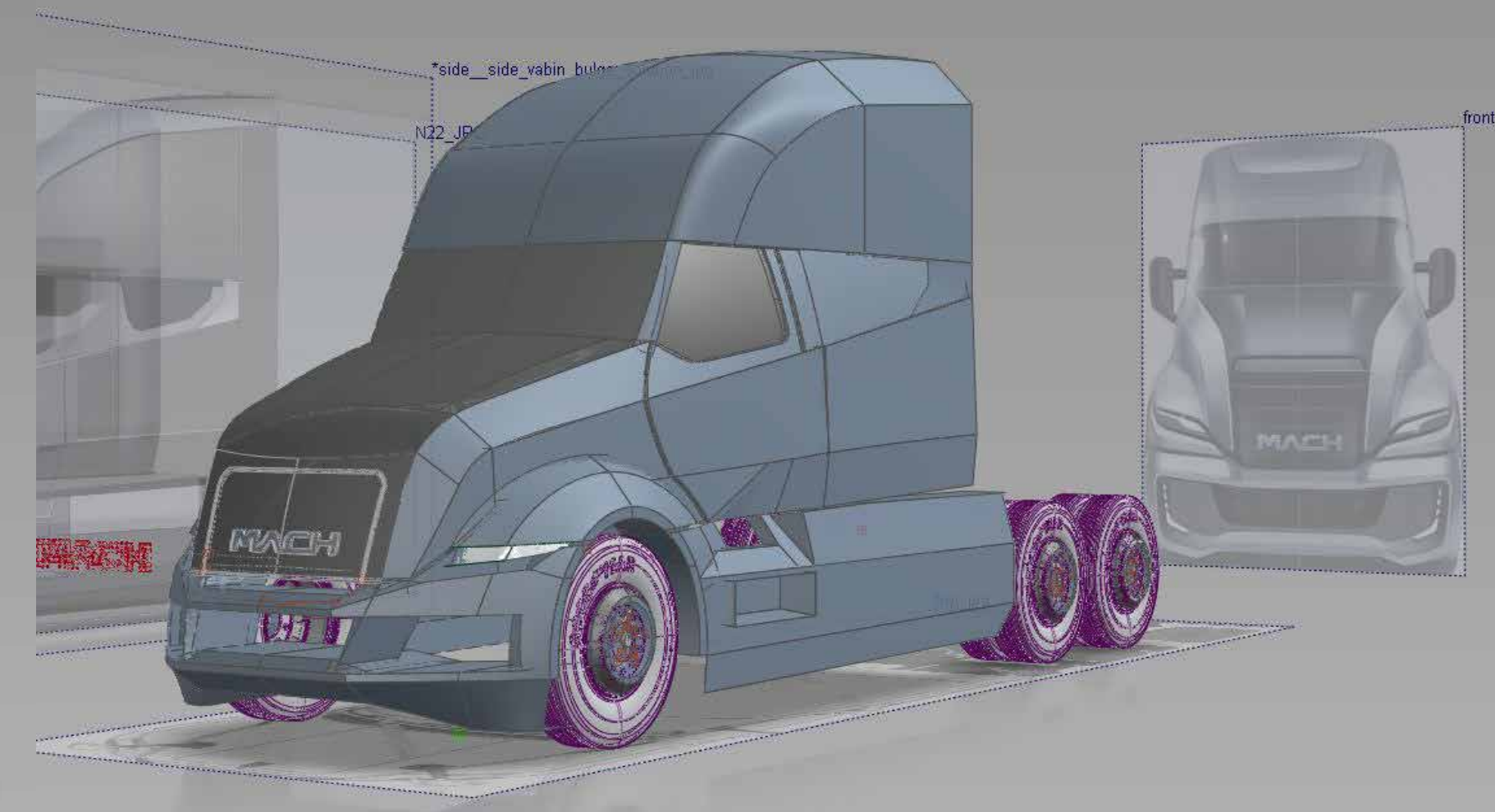
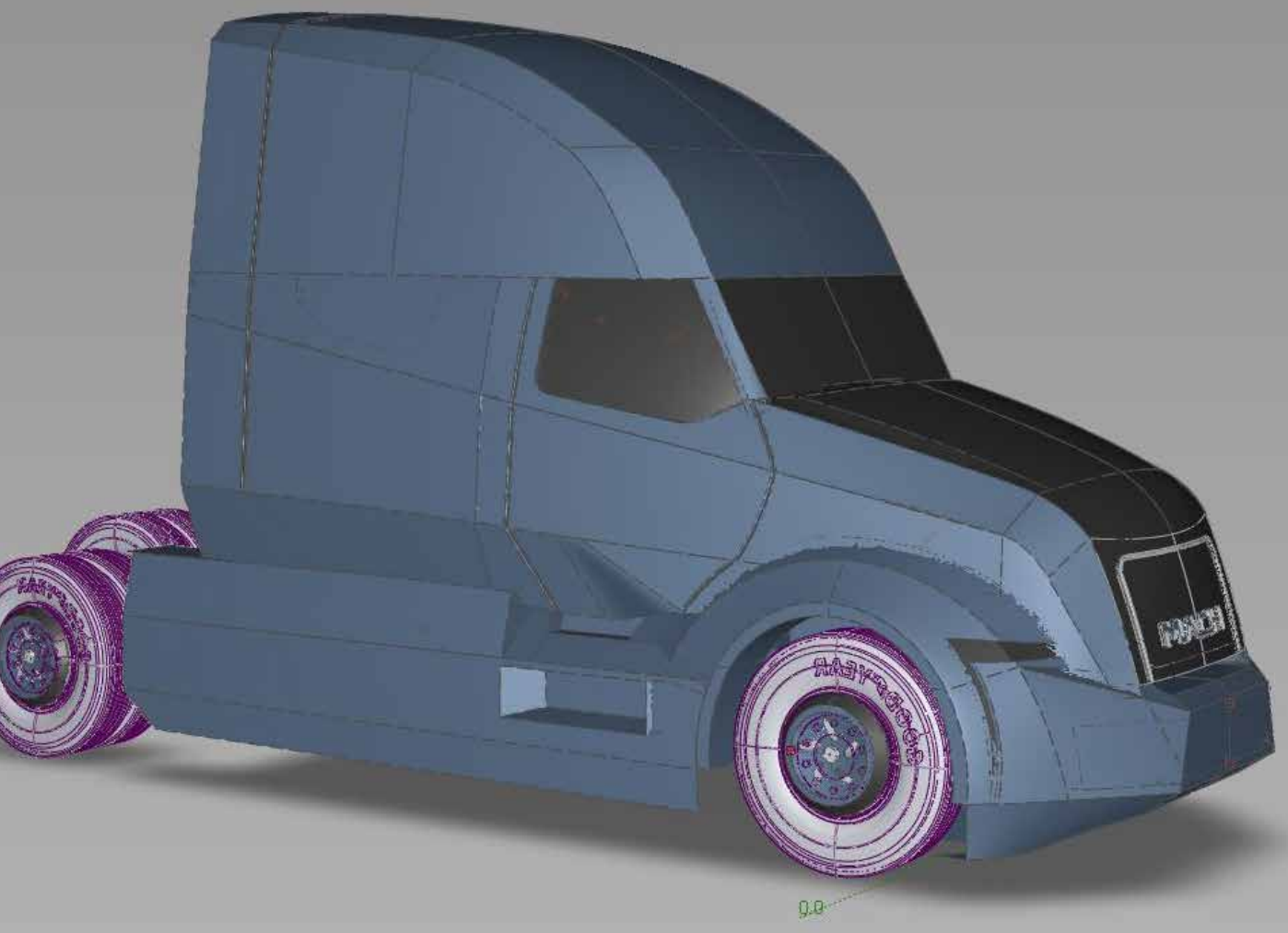



Interior exploration, approach was to create a unique experience, yet familiar environment, the interior is a homage for early trucking in the 1900 with modern Tech influence.



// Interior -
light& ambience exploration

MACH
THRONE

//Ured visualization

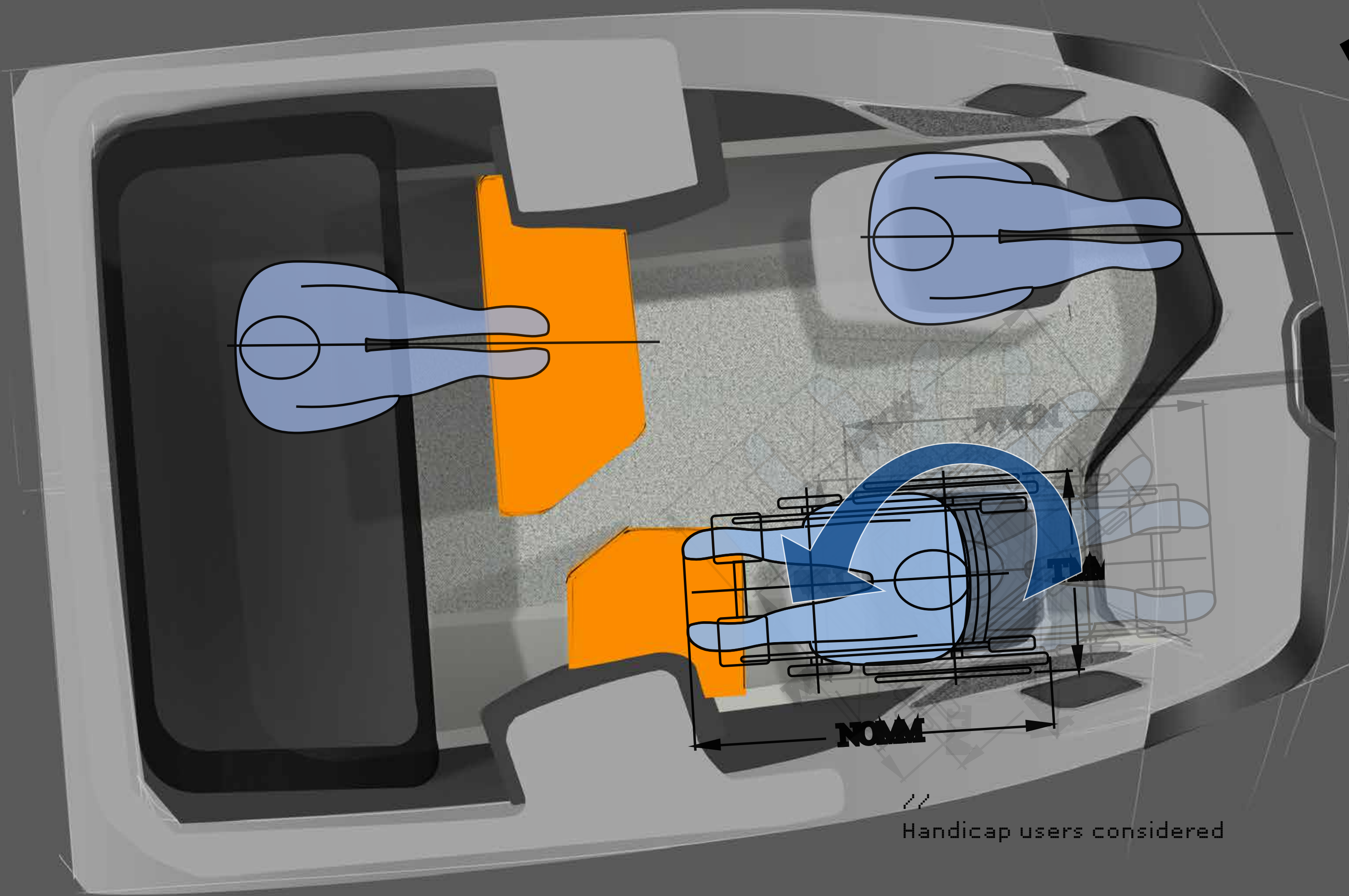

// Handicap users considered

// AIM is promotes users' self-sufficient. the right TABLE placement and manage the overall space inside the cabin.



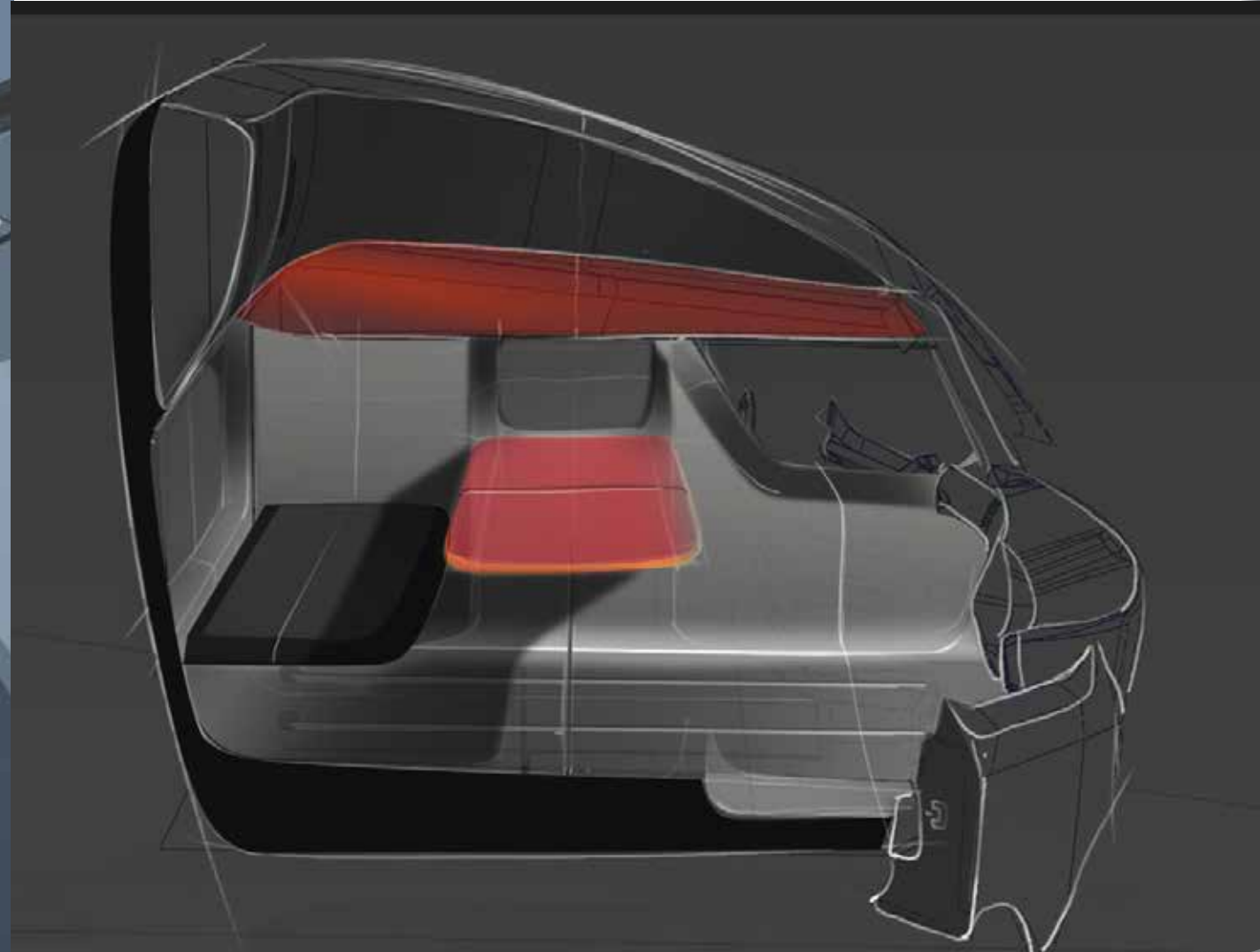
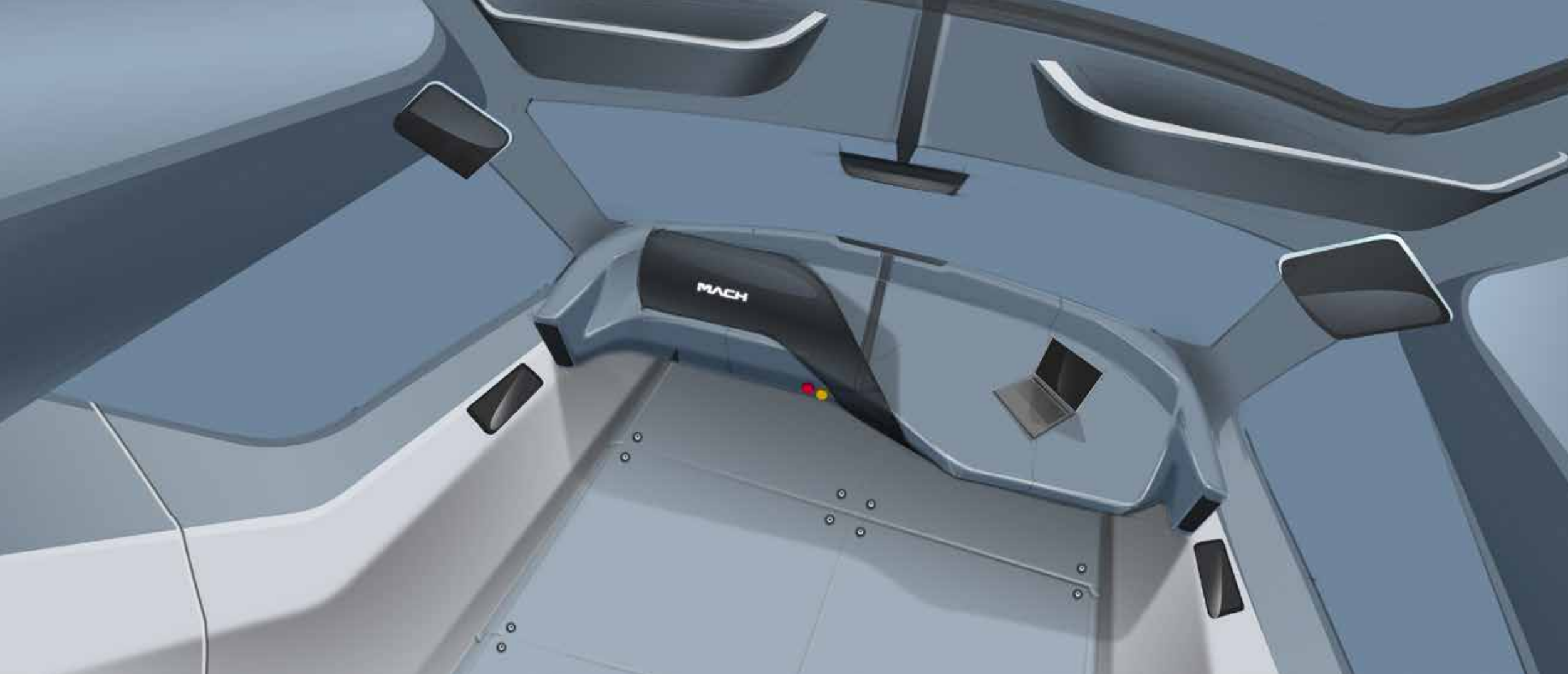

both interior and exterior design process have to match with the design philosophy of self-sufficiency and retro.

an aesthetic was needed to fulfill a traditional attitude in terms of C&T

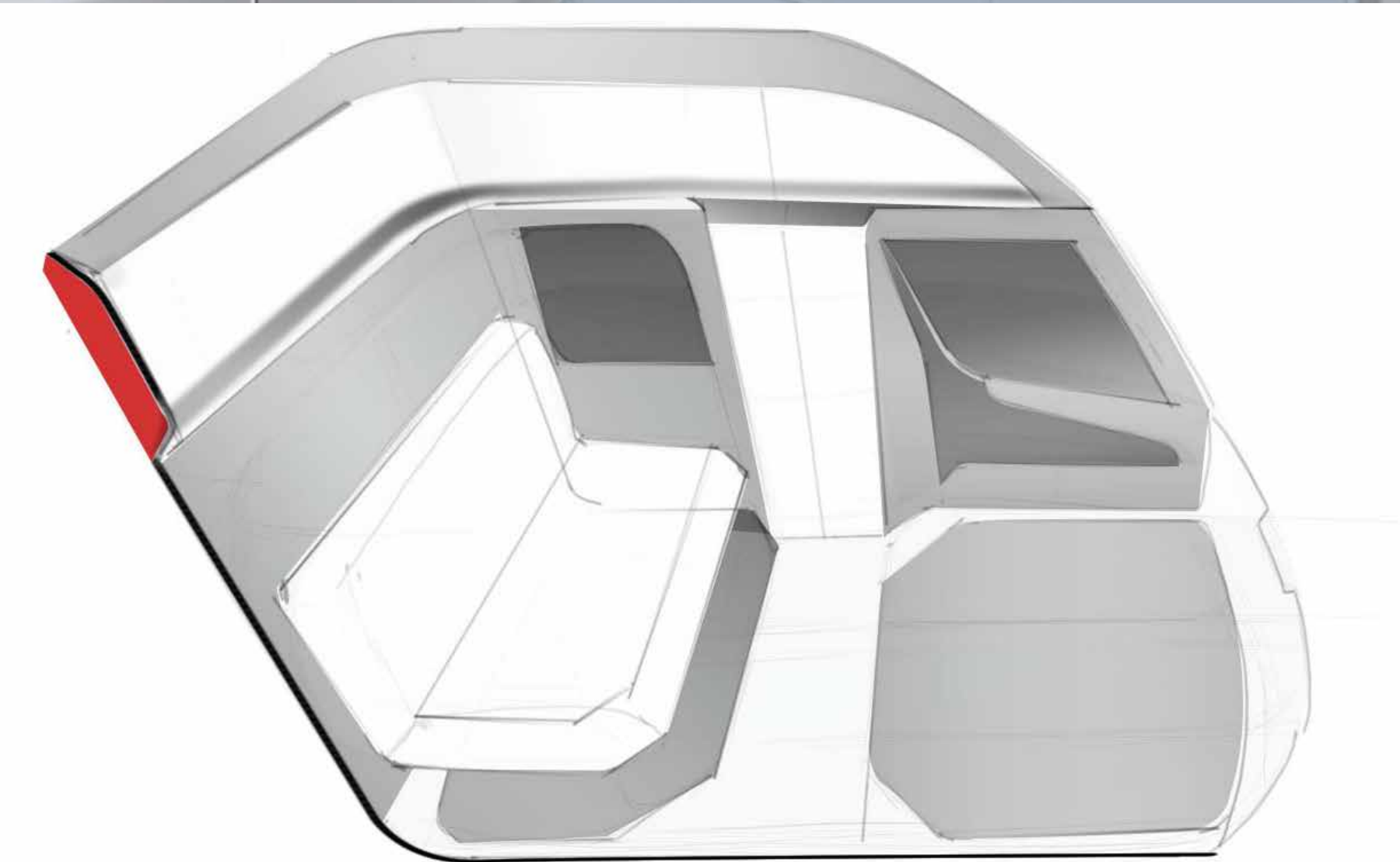

A poster to explain the interiors.

This was my major role in a team.

communication via compile and presentations to the decision-making team.

whilst

working from home.

1 square steering wheel - drive by wire reduces the overall volume of the interface

toggle/button/knob to navigation on the IP screen

MACH

MACH

screen for to replace rear view mirror and side view mirror

2 80% of the dashboard and Digital IP is drive-centric, 20% display with rest of the cabin.

3 Airbags and Hidden Table that comes out for the passenger

4 Information is spread across the cabin Space.

table for side passenger

screen on dashboard

screen on door handel

A large sunroof makes the space inside the cabin more spacious

5 a crossbeam to support an open roof for sunlight.

6 organic placement of the screen which overlooks both rear-view and side view

7 Seat with a single dial for settings

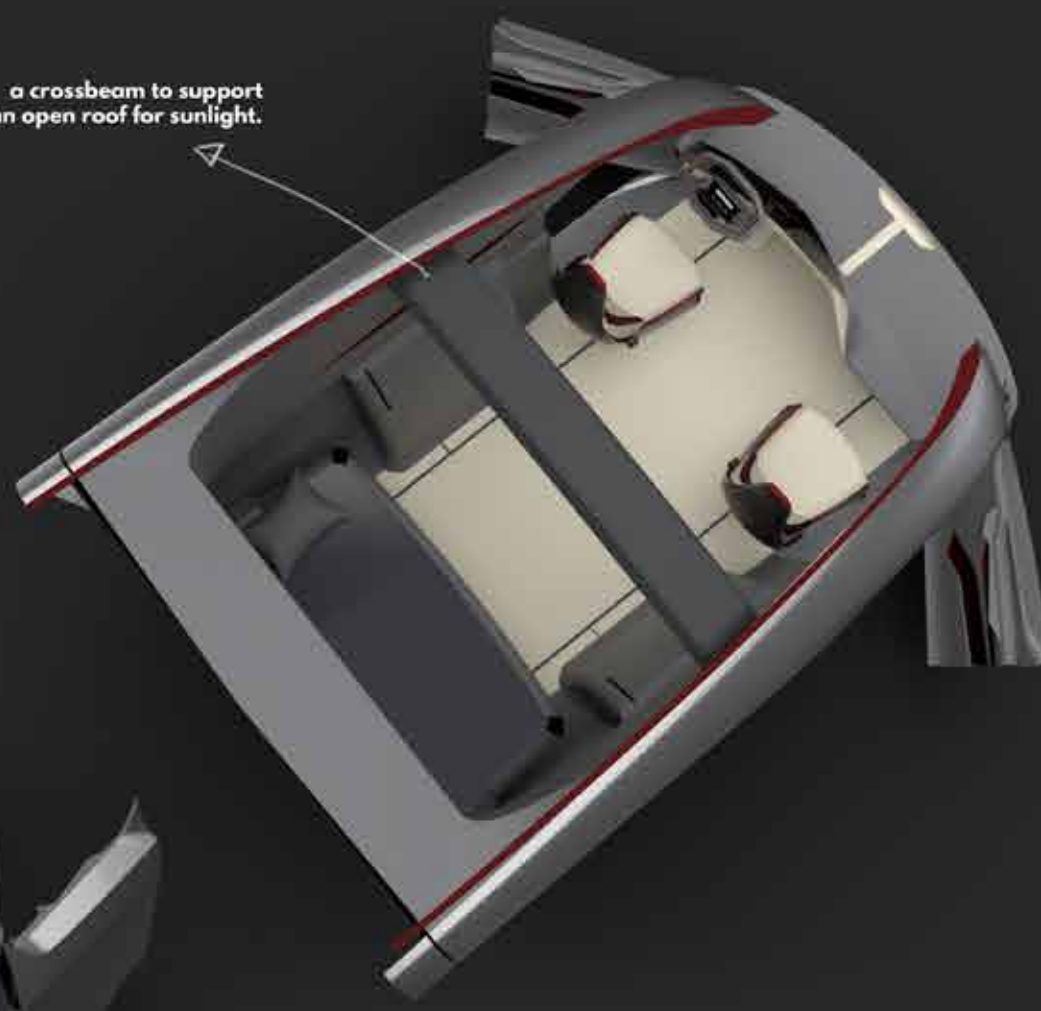

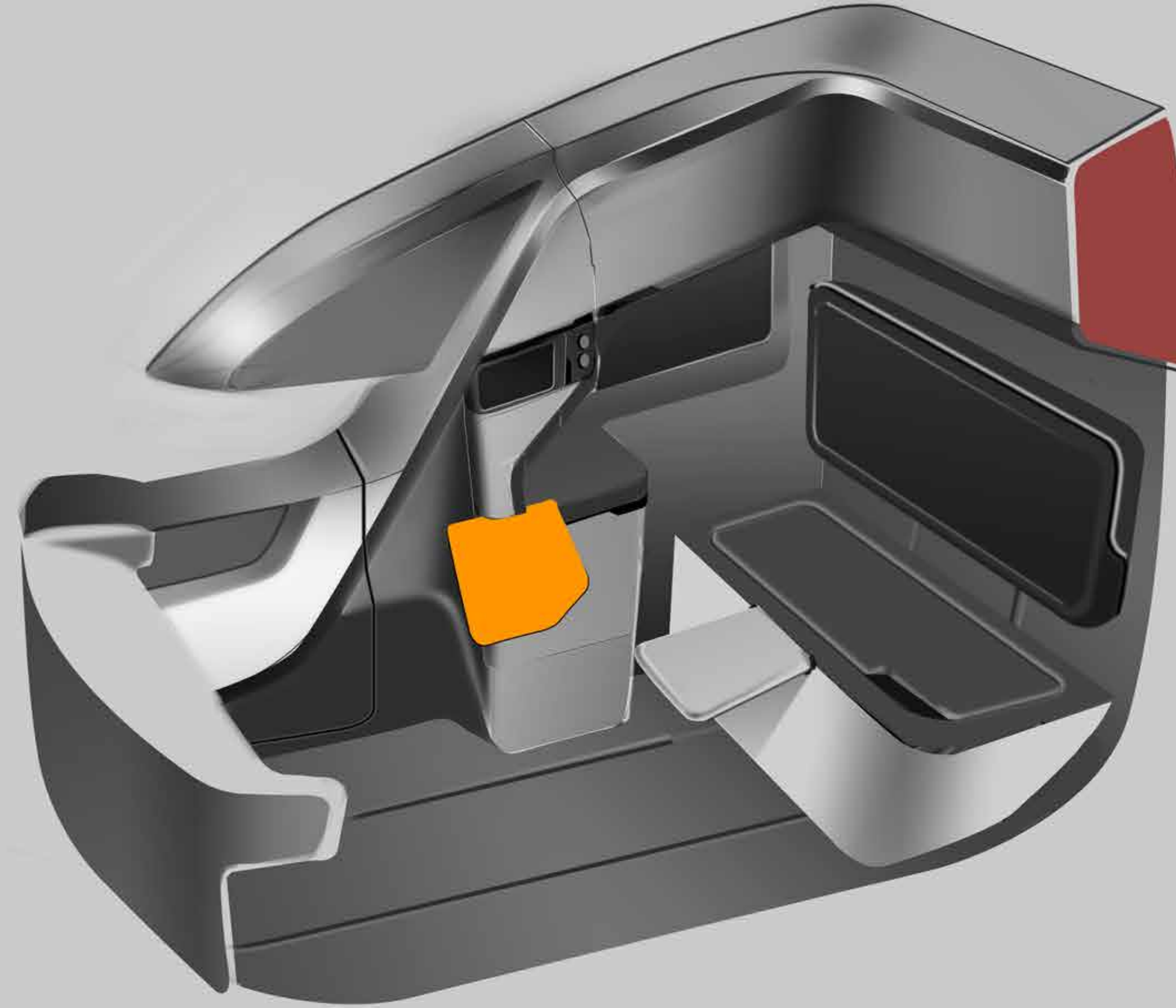
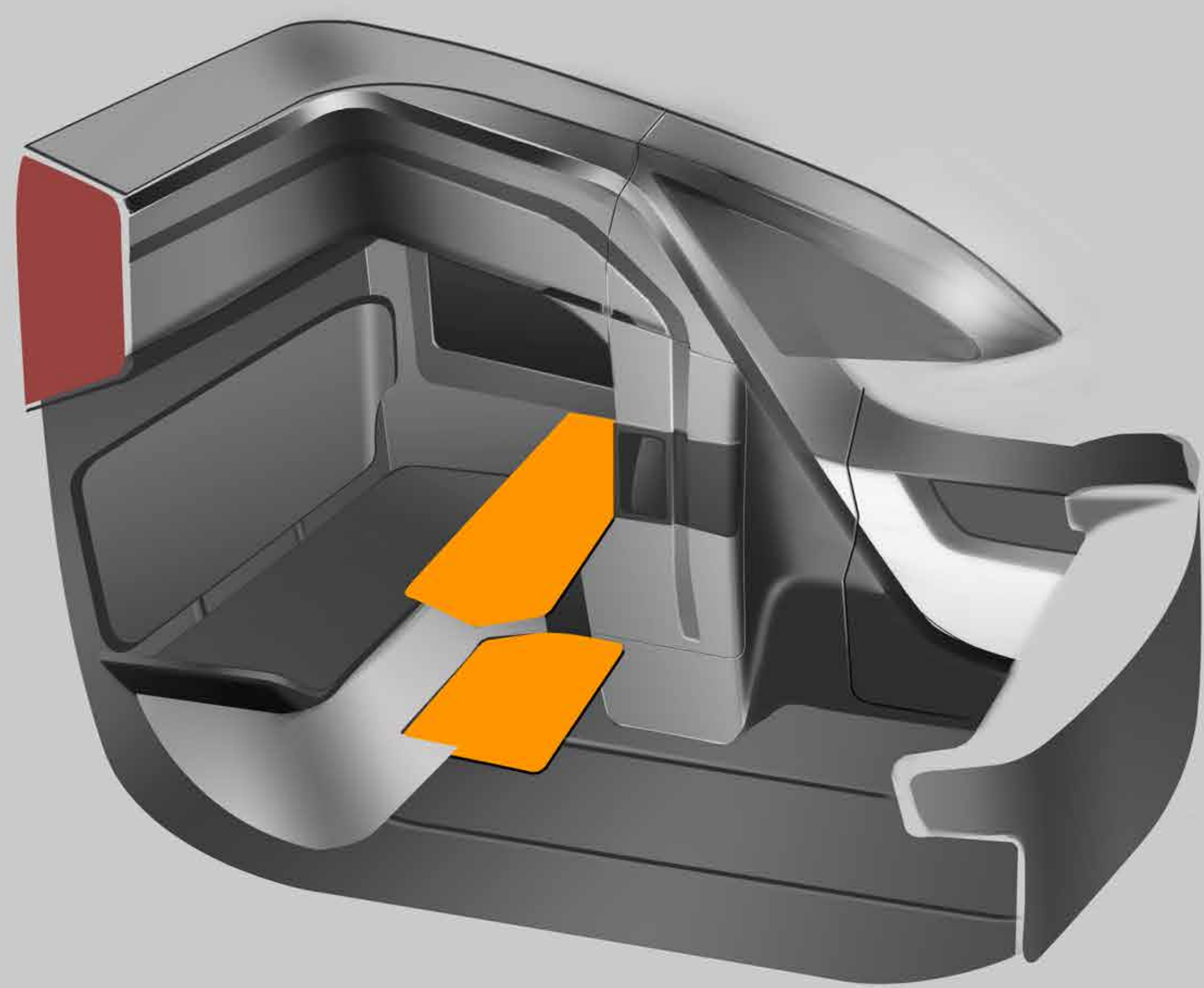

the project need an approach of a motor home,

where every corner had to have a **purpose.**

taking inspiration from Space

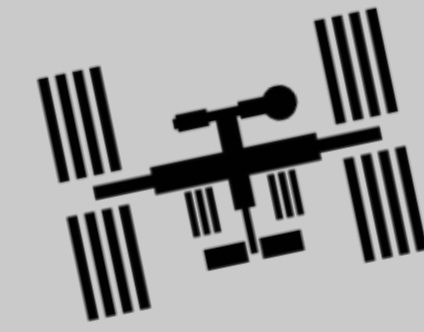

programs like the **ISS**

utilize space as work and livable habitat

for an **extended** period of time.

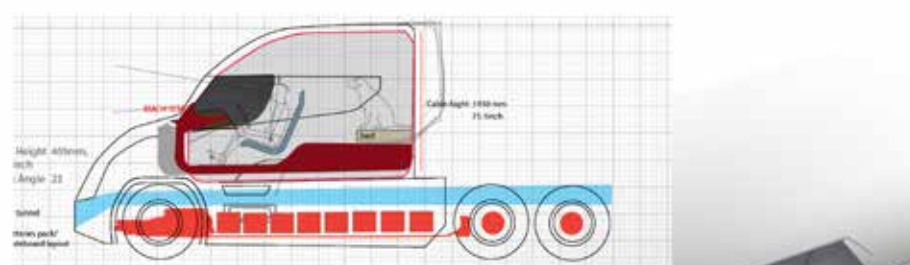
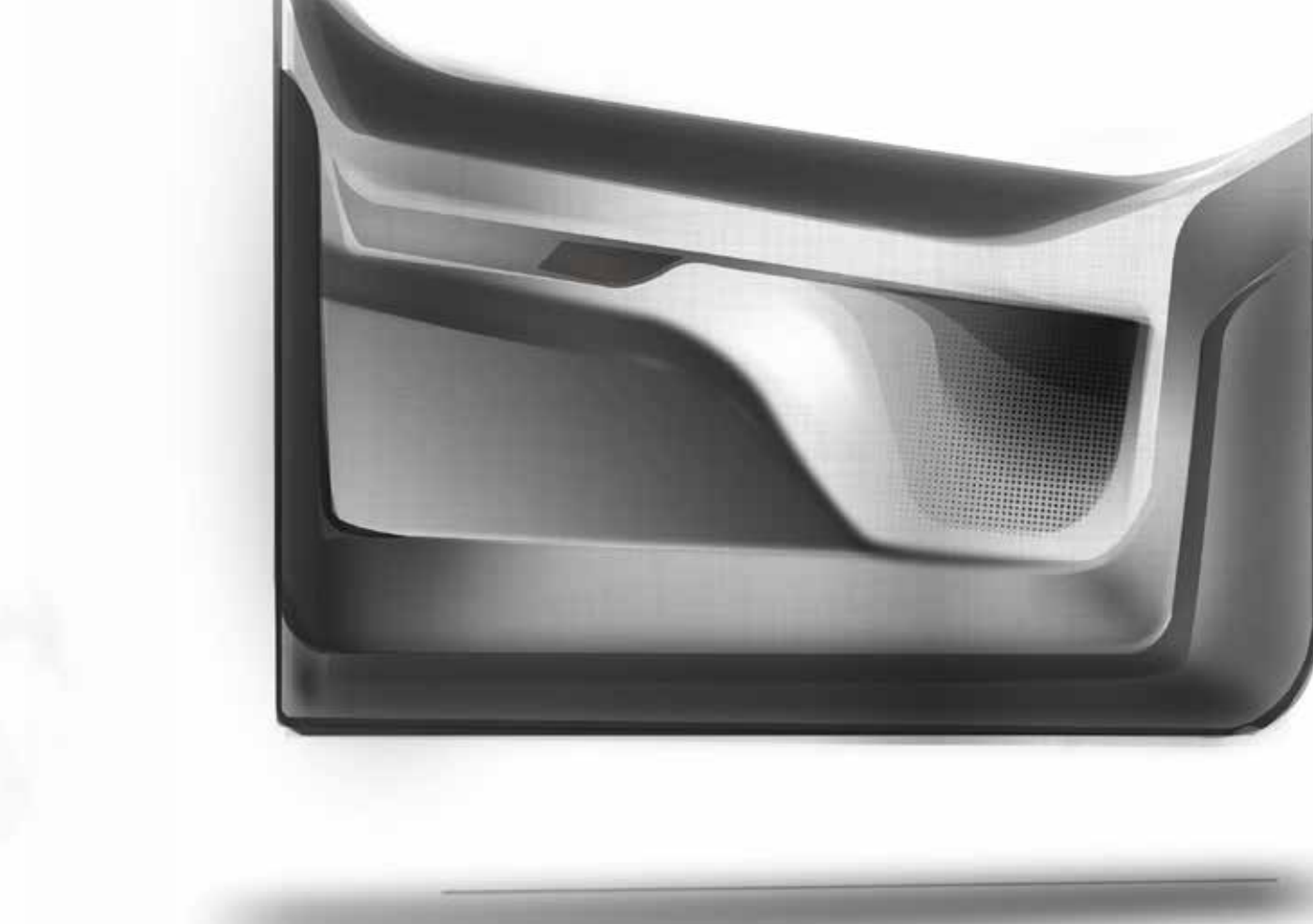
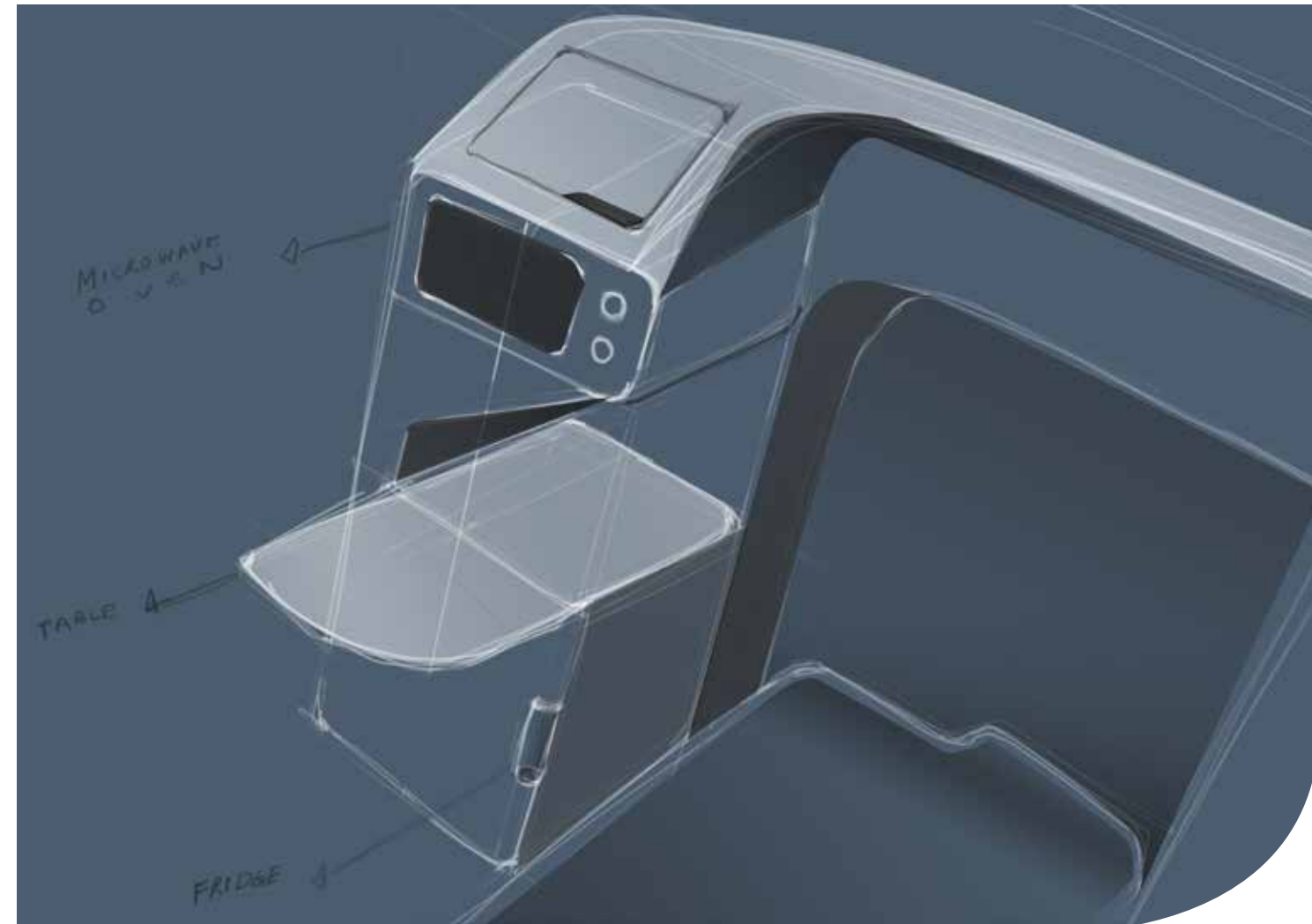

MACH

4



#Lamborghini
super sport sedan.

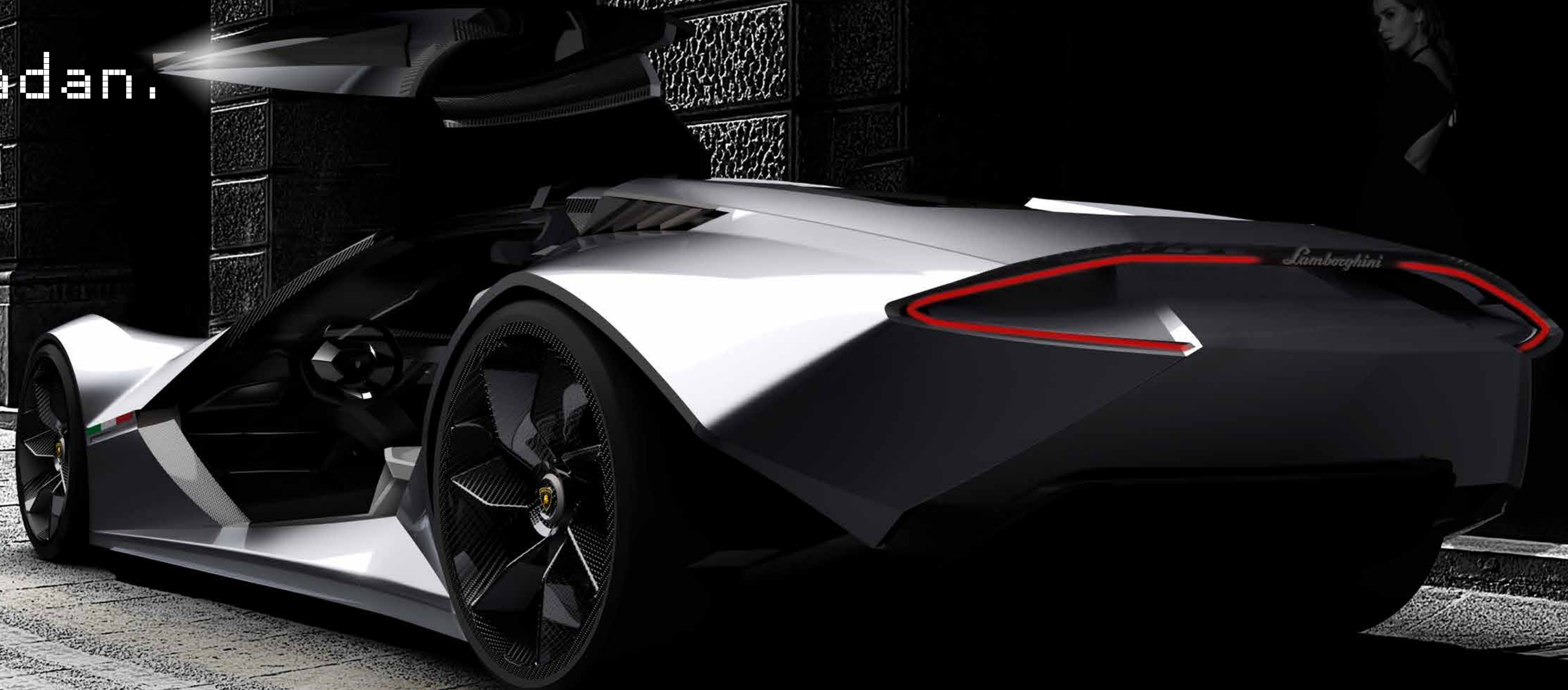

#Lamborghini
super sport sedan.

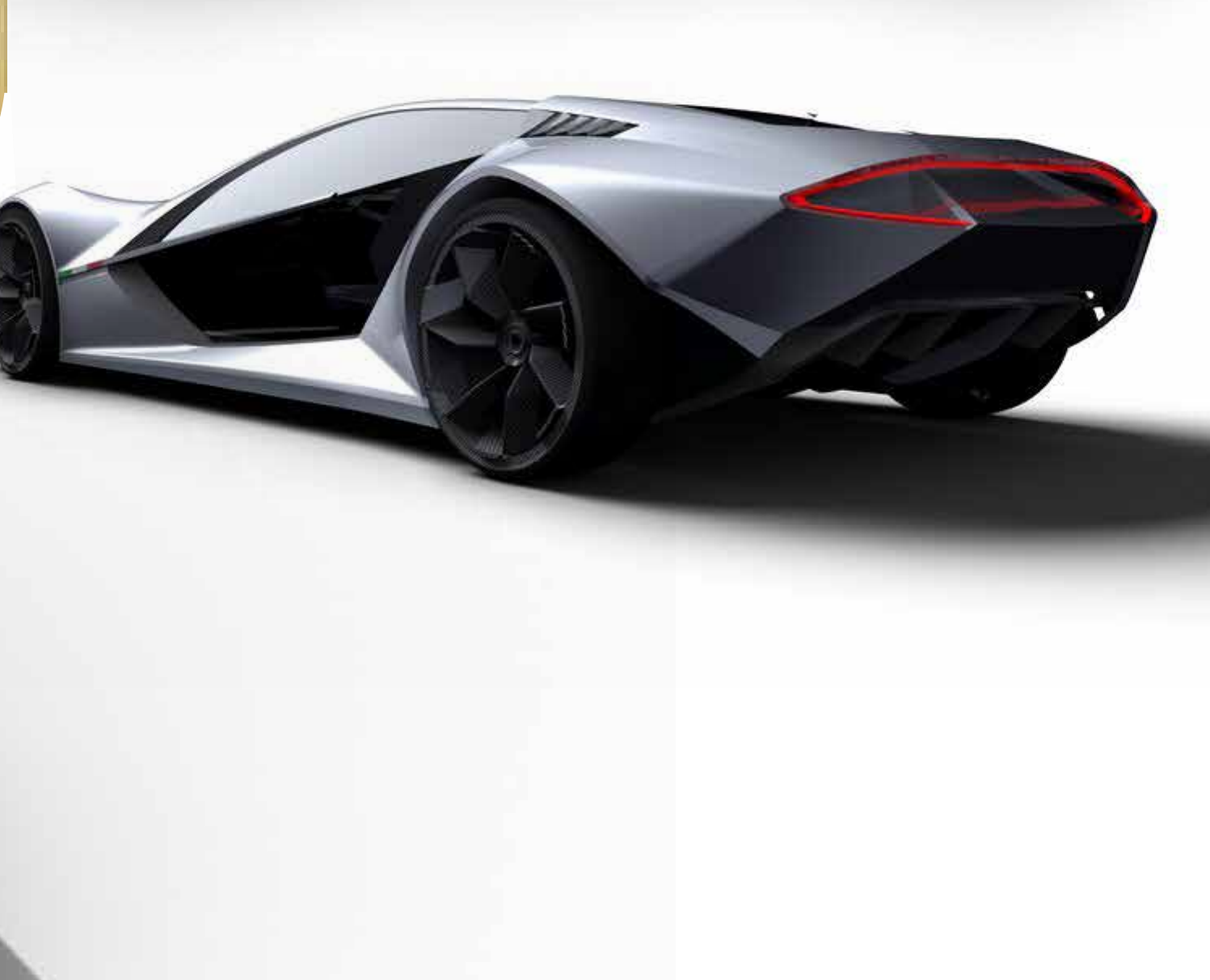
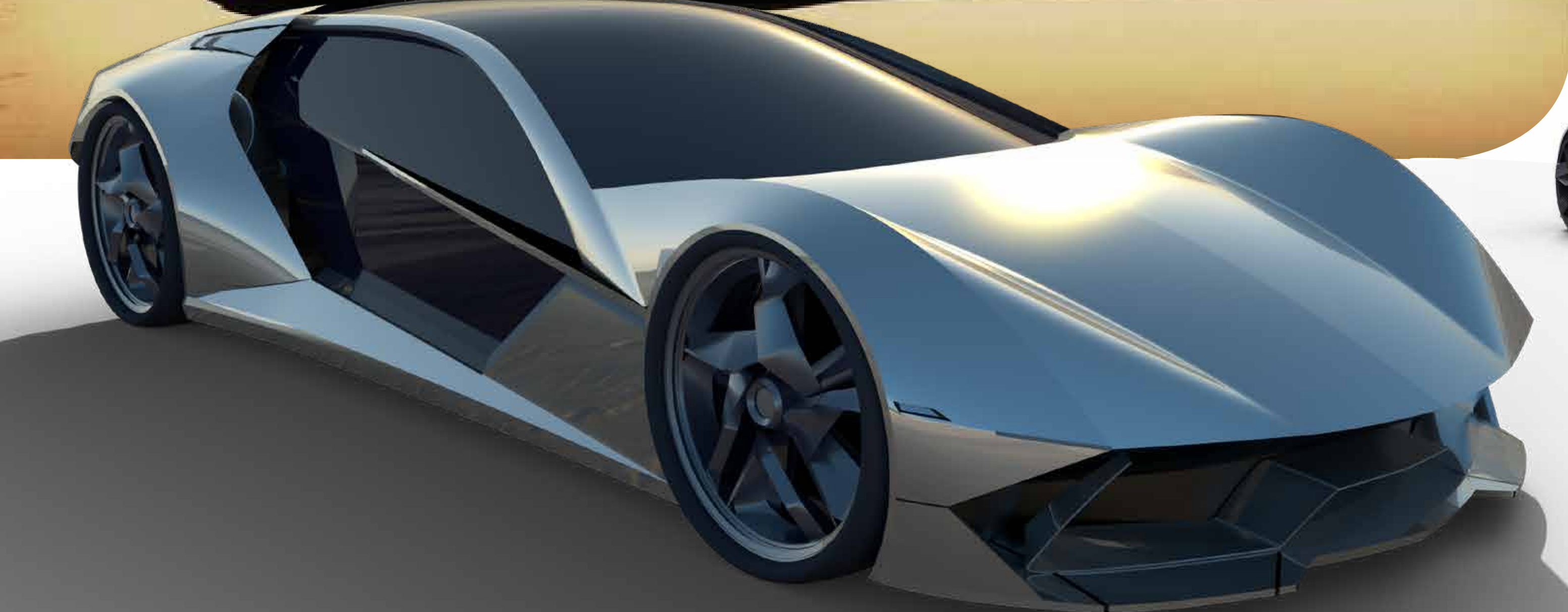
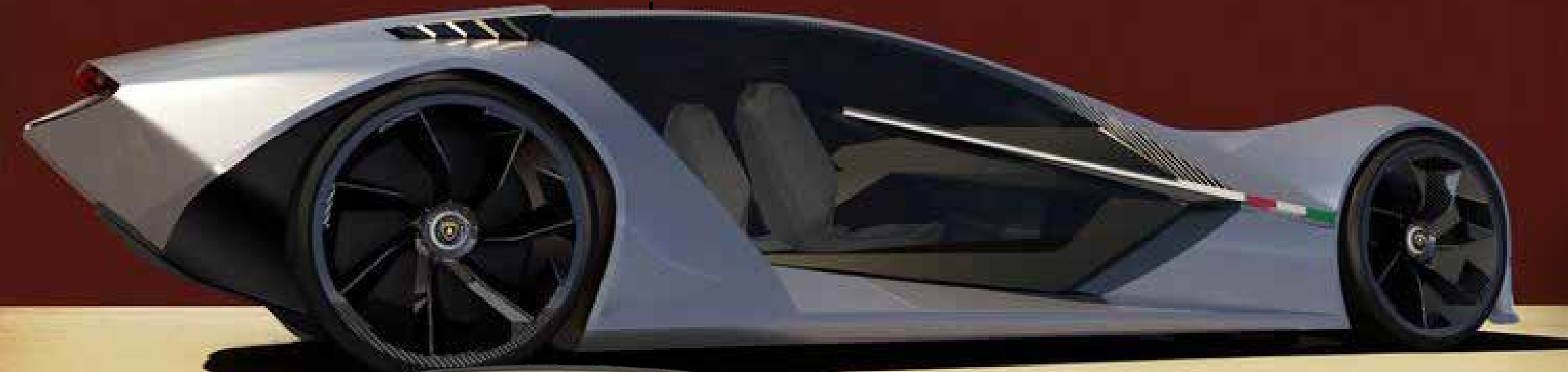

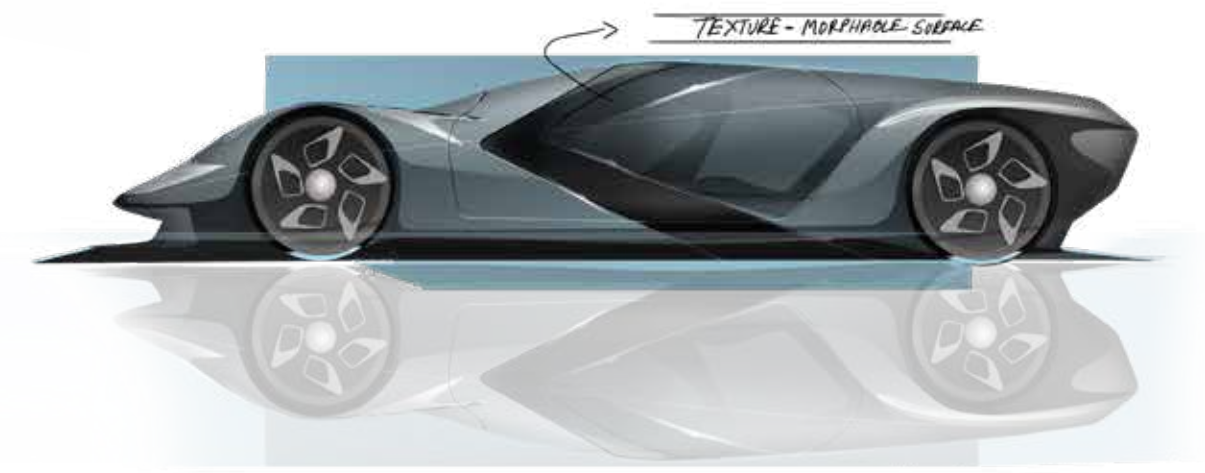
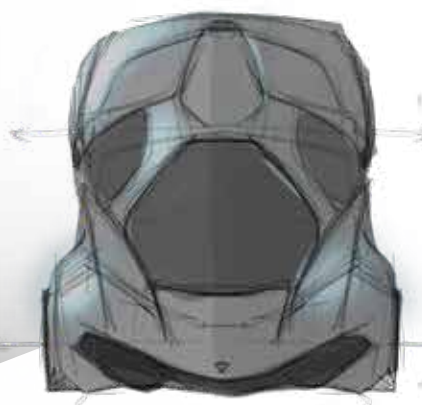
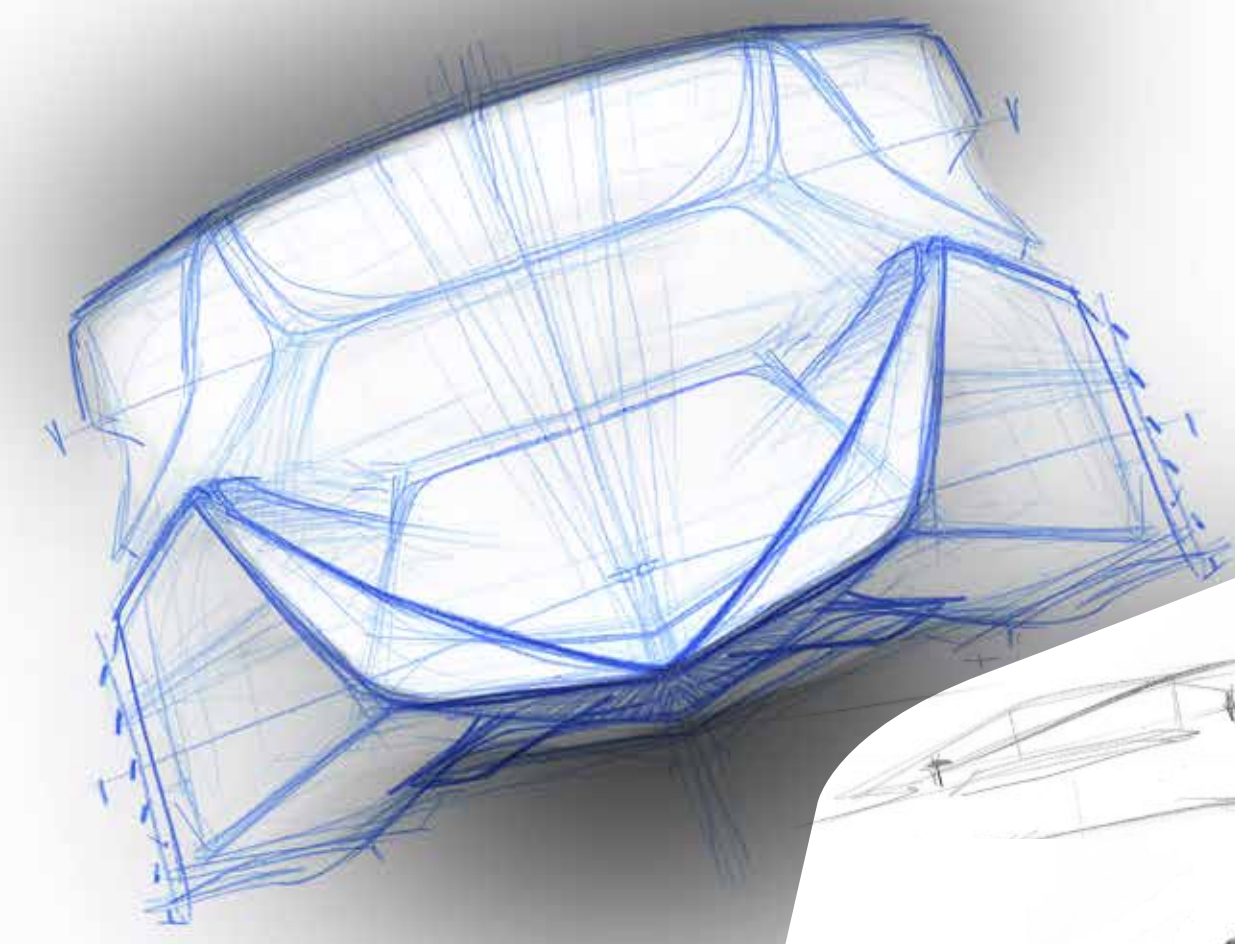
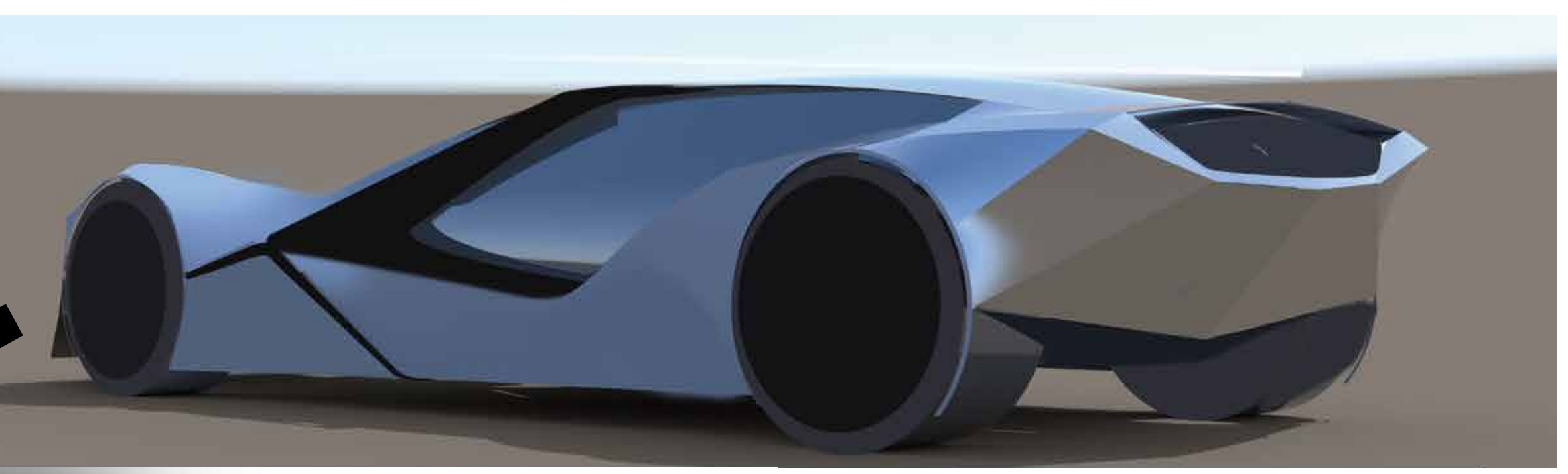
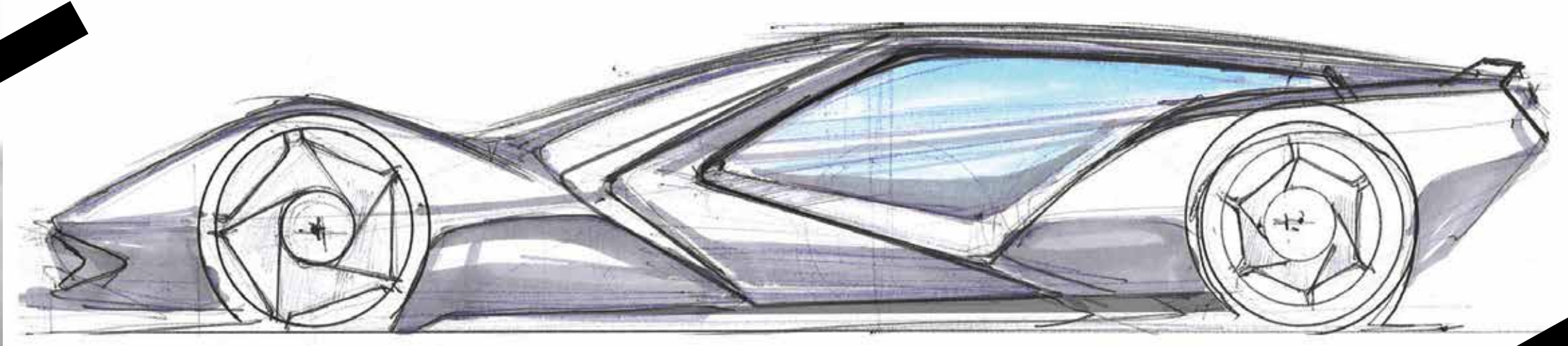
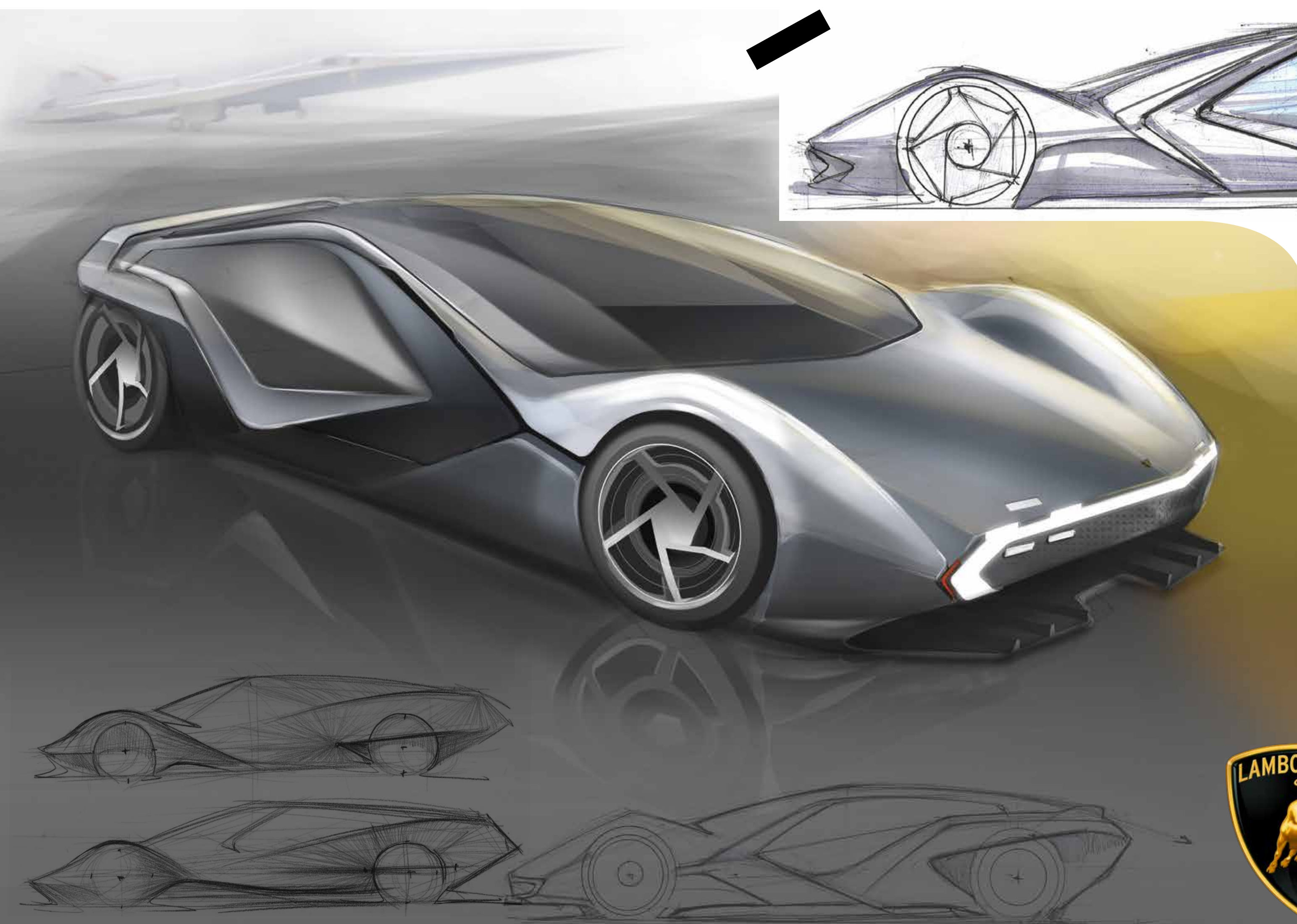

Development

\# 4 seater
&
2 door ingress

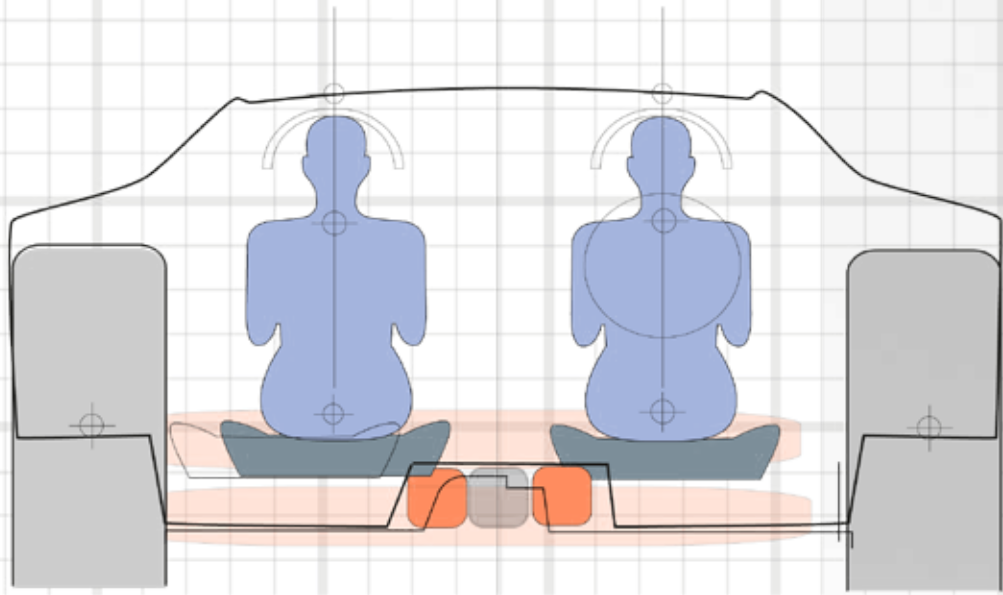

2200mm -Width

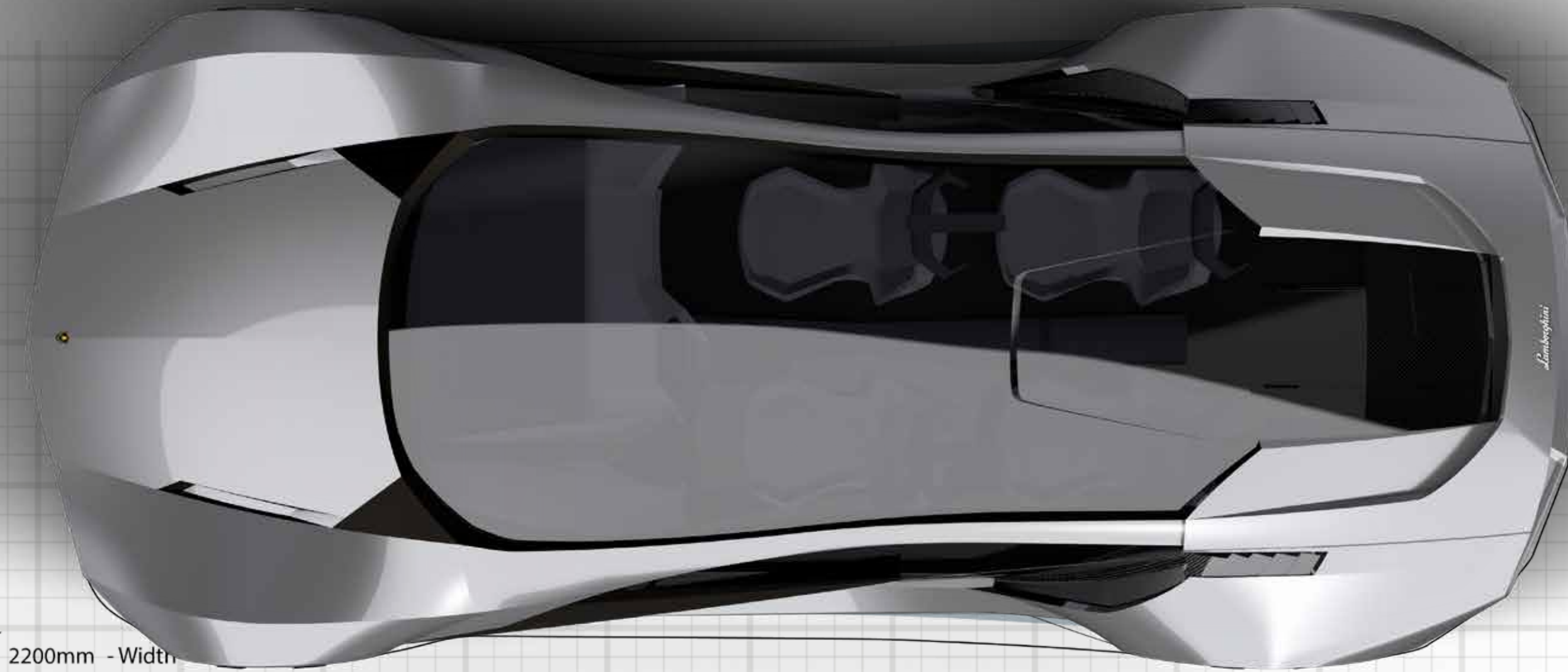

2200mm -Width

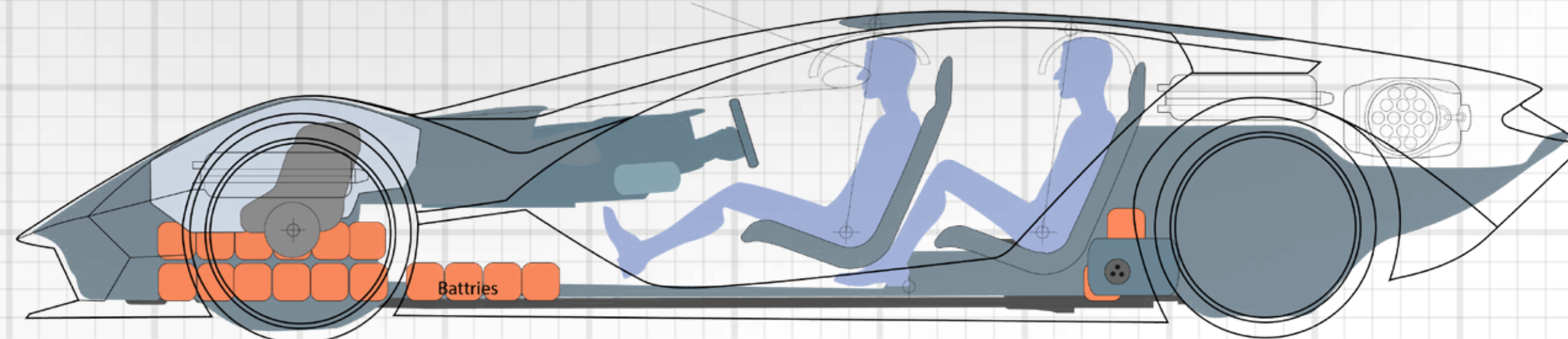

1105mm-Height

255/30ZR20 (92Y)

355/25ZR21 (107Y)

3400mm-Wheel base

5300mm-Length



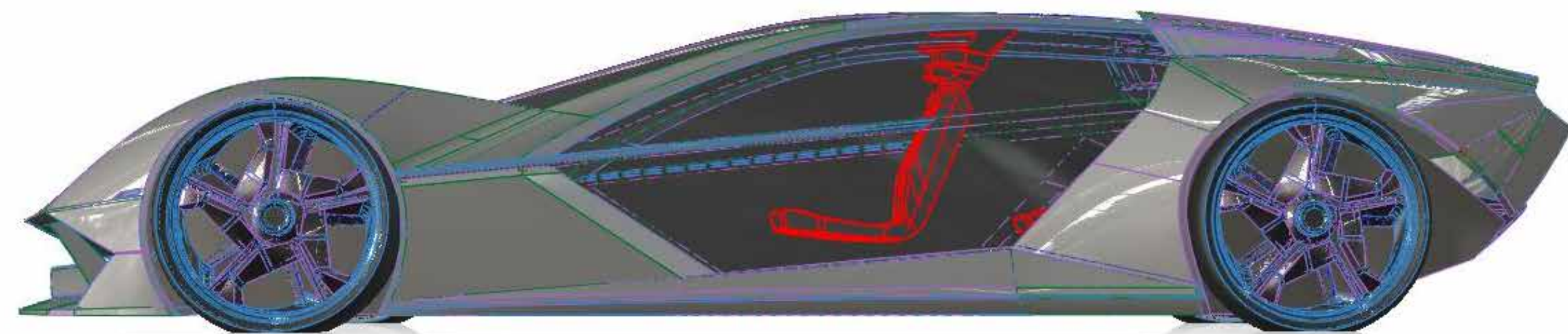
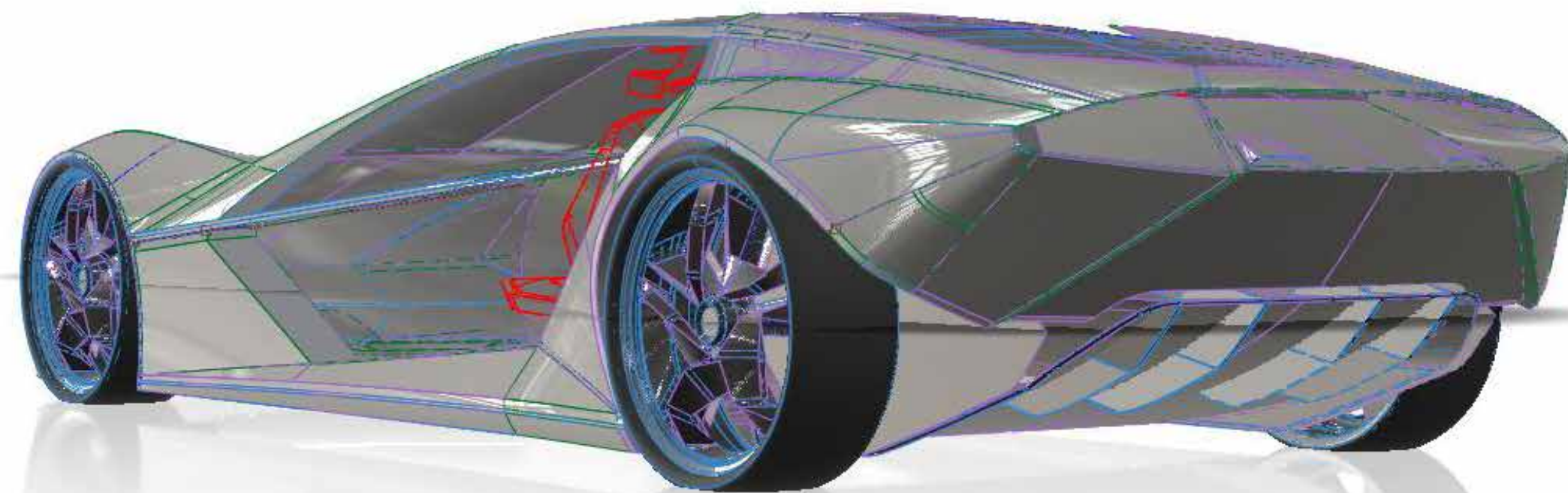
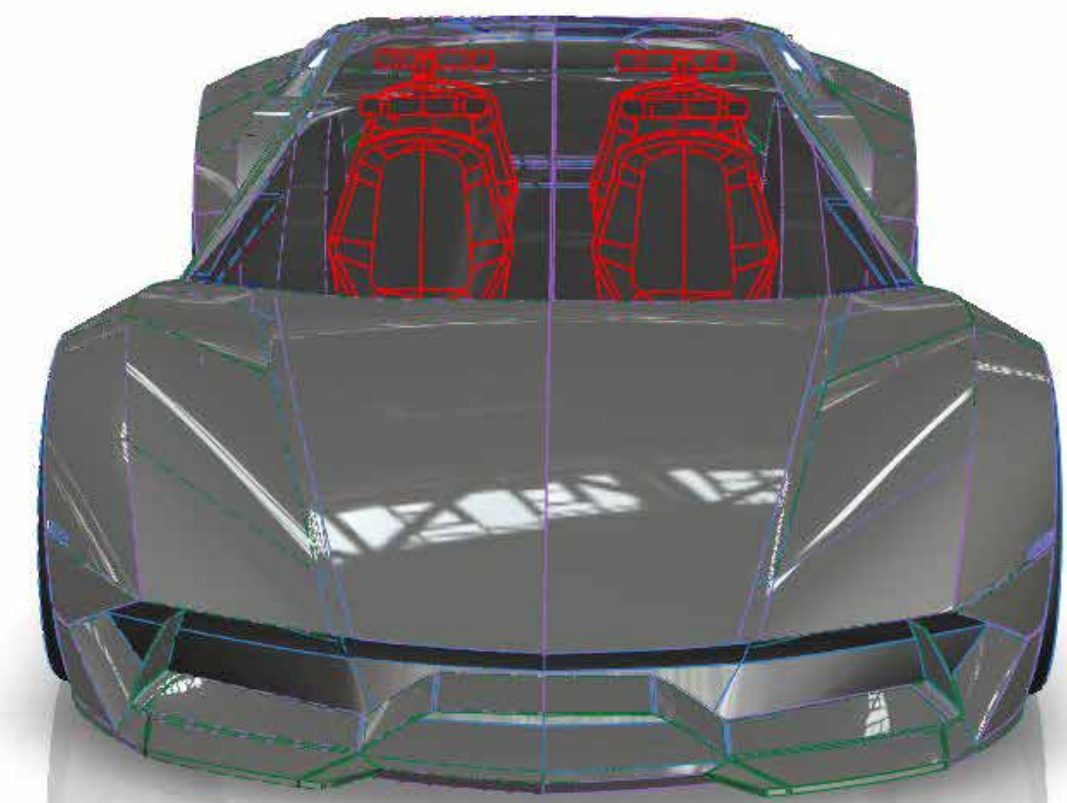
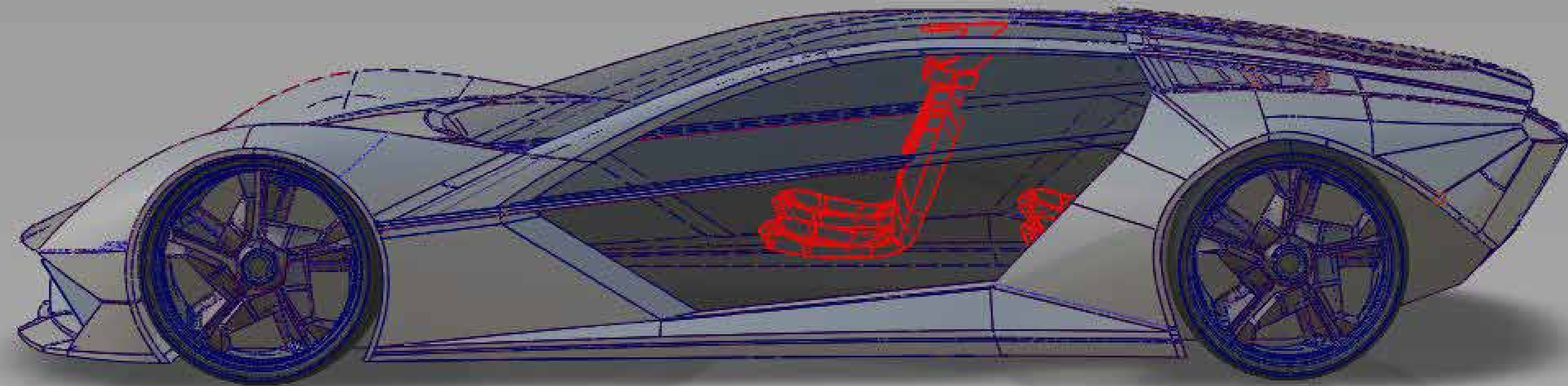
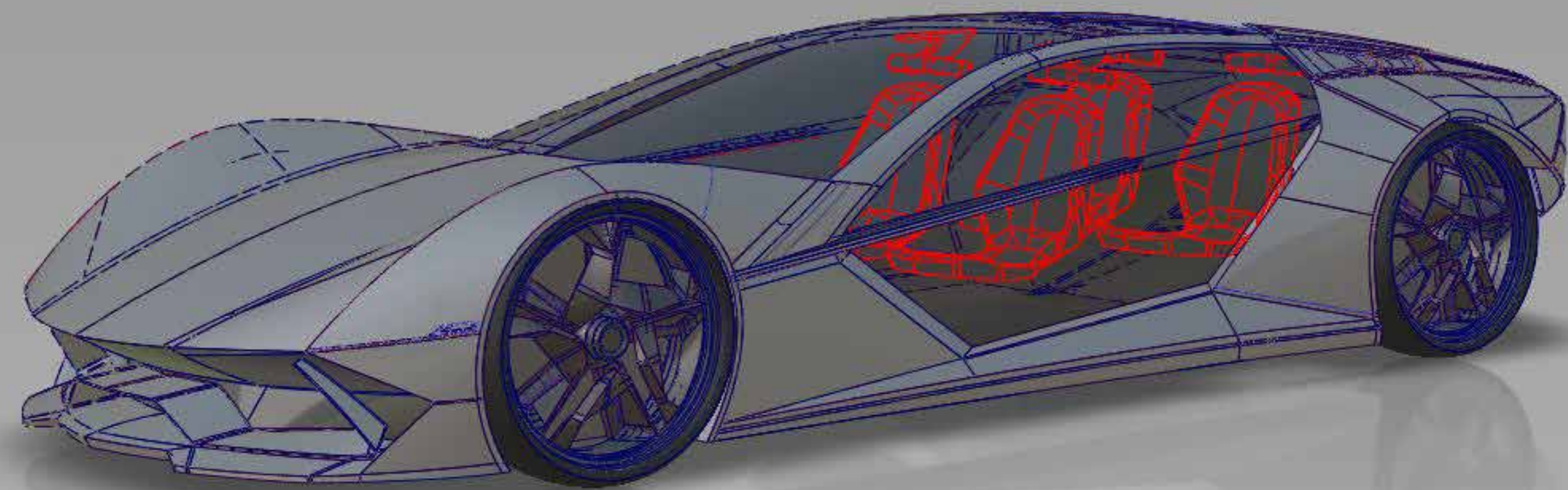

5



// electric SUV



✓ Keysketch

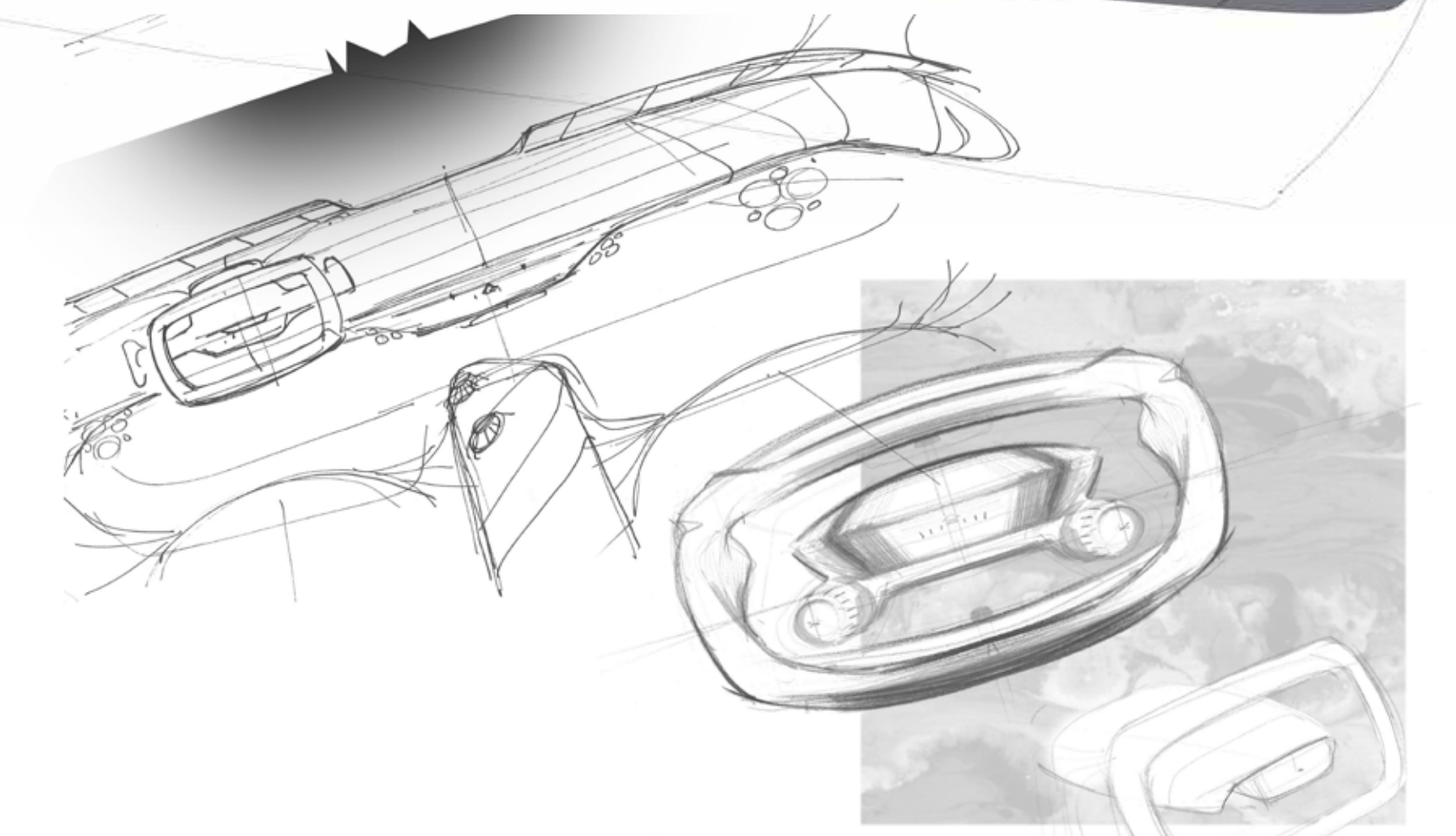
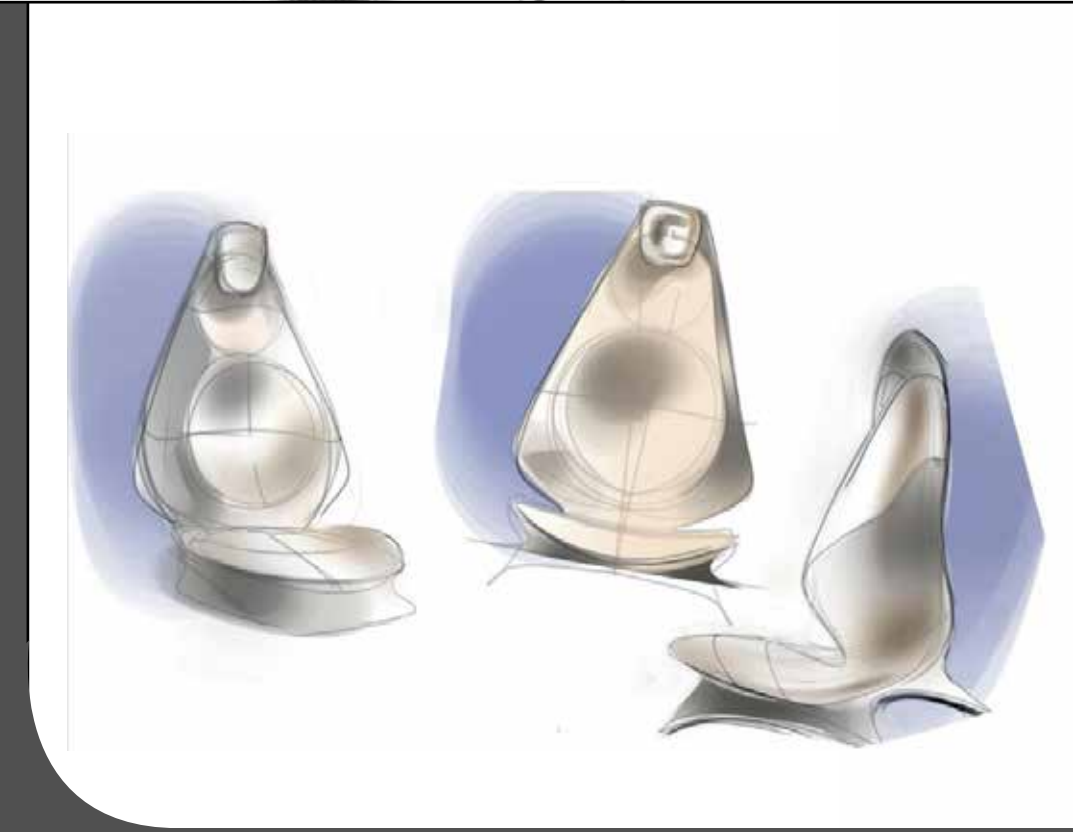
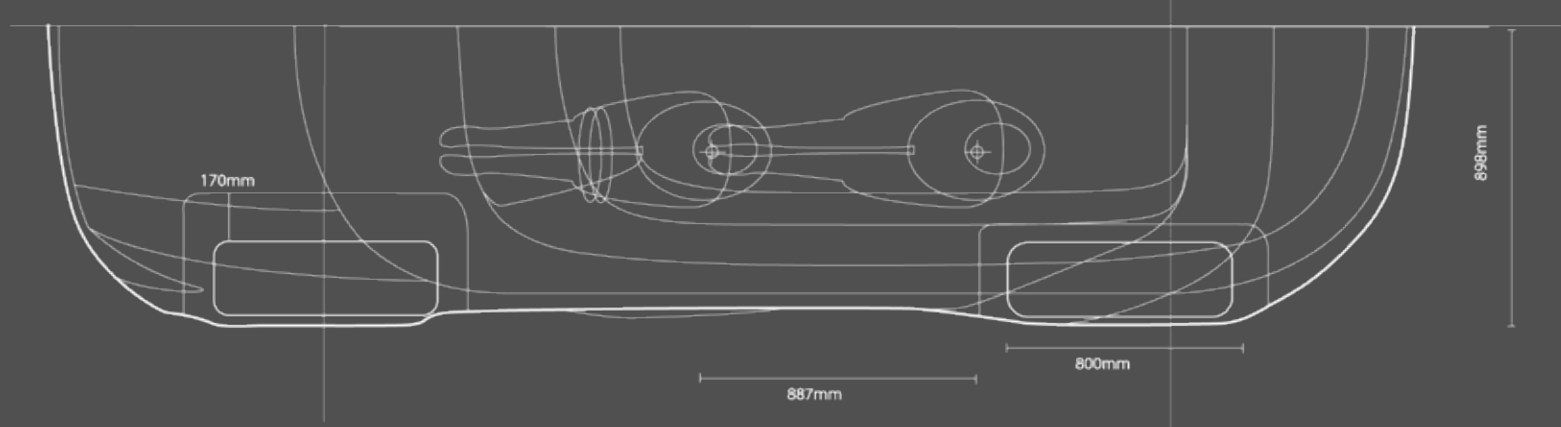
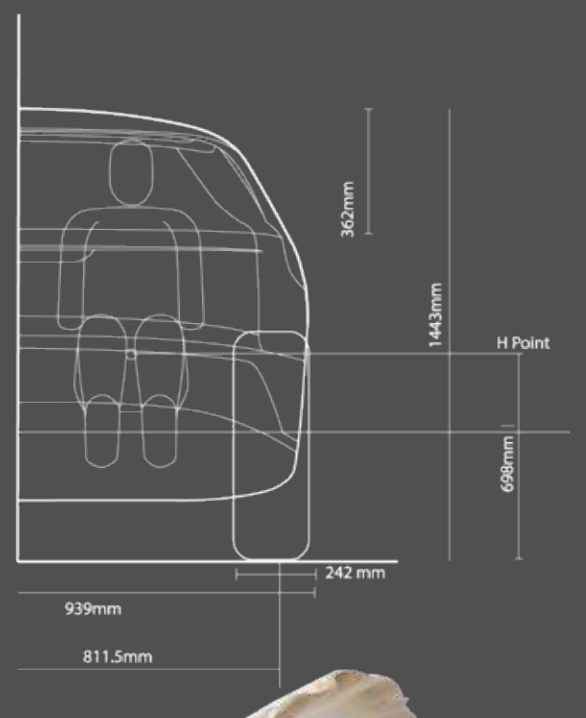
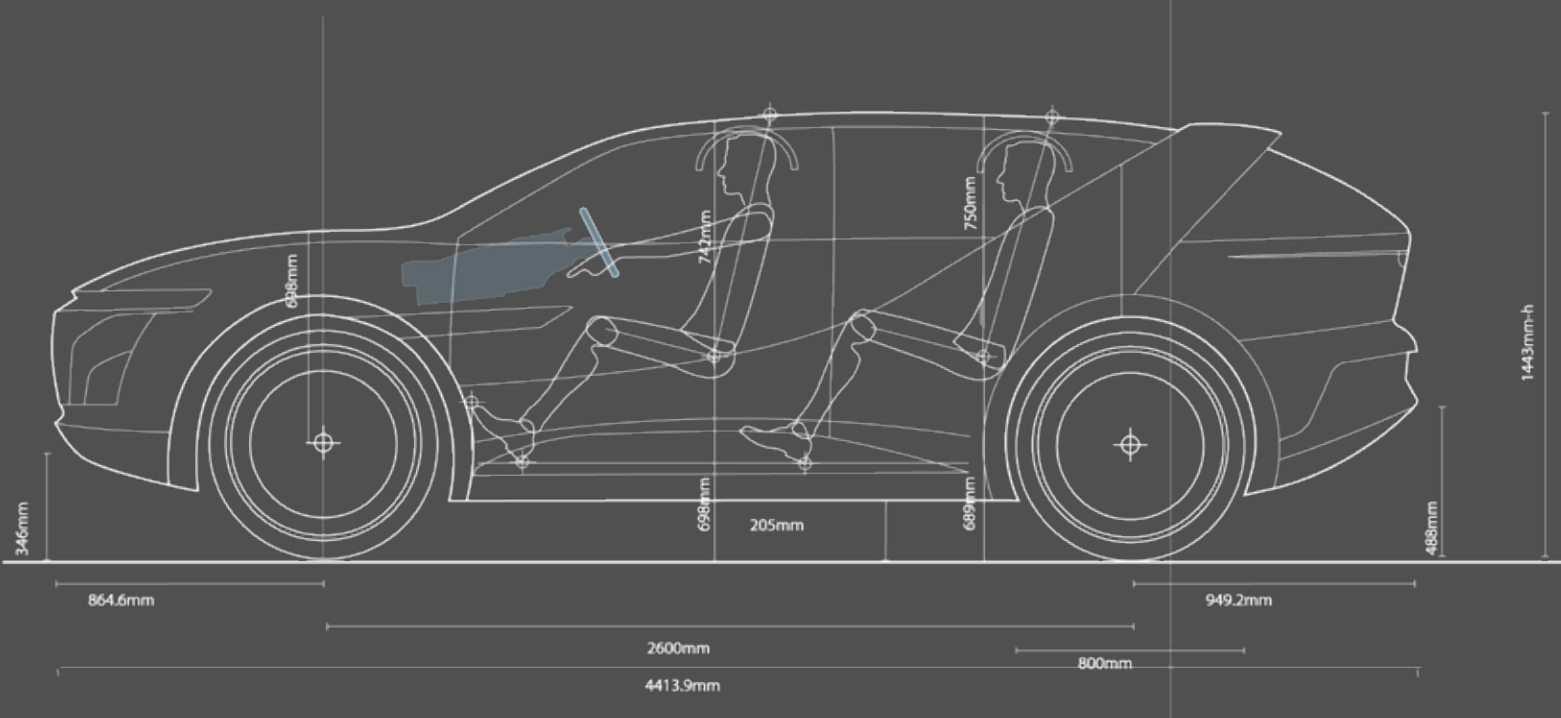
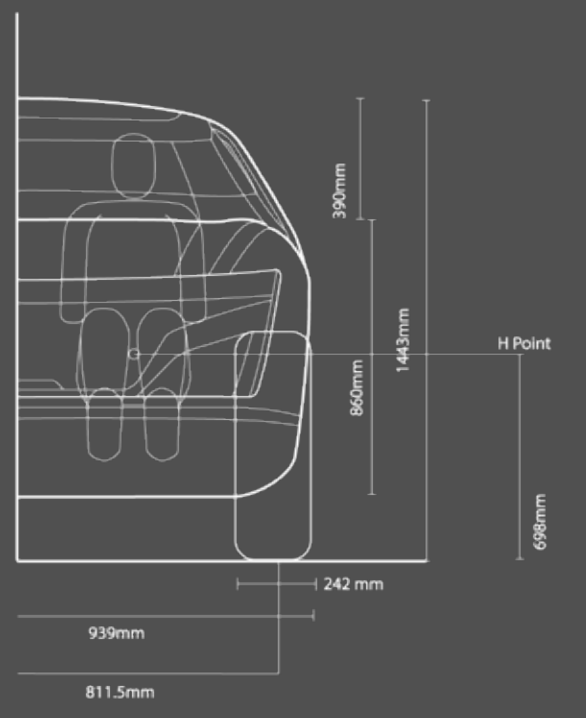
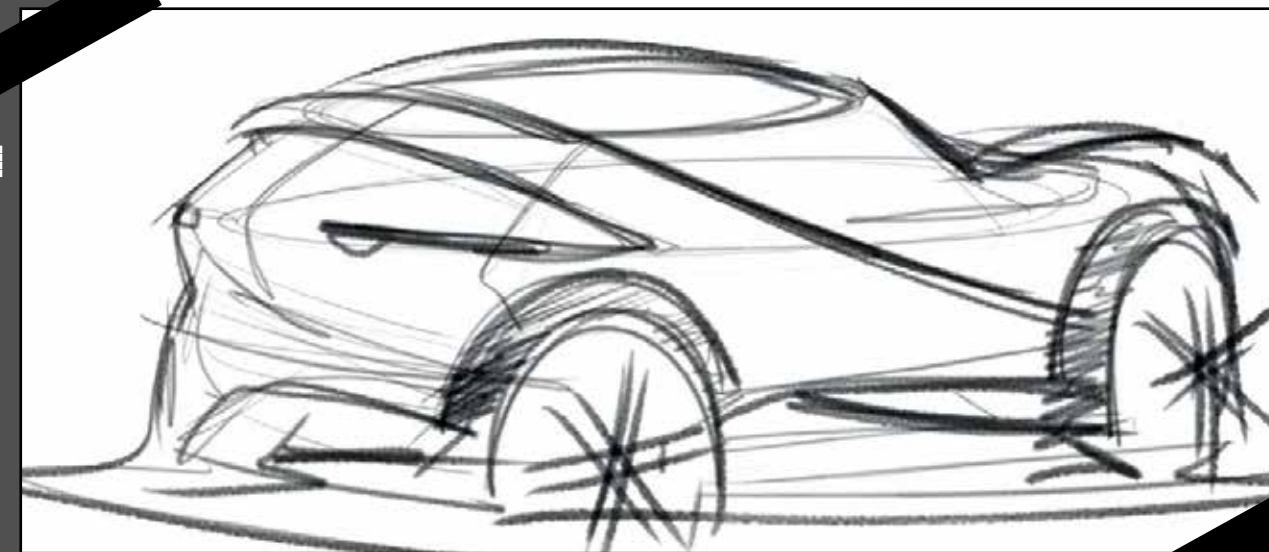

✓# Inspired by Oyster shell

