

CAR DESIGN

PORTFOLIO

ABHINAV
KULKARNI

ABHINAV
KULKARNI

- ● ● JR. TRANSPORTATION DESIGNER (EXT & INT)
- ● A CLASS-SURFACE MODELER
- ● ● VISUALISATION AND PACKAGING

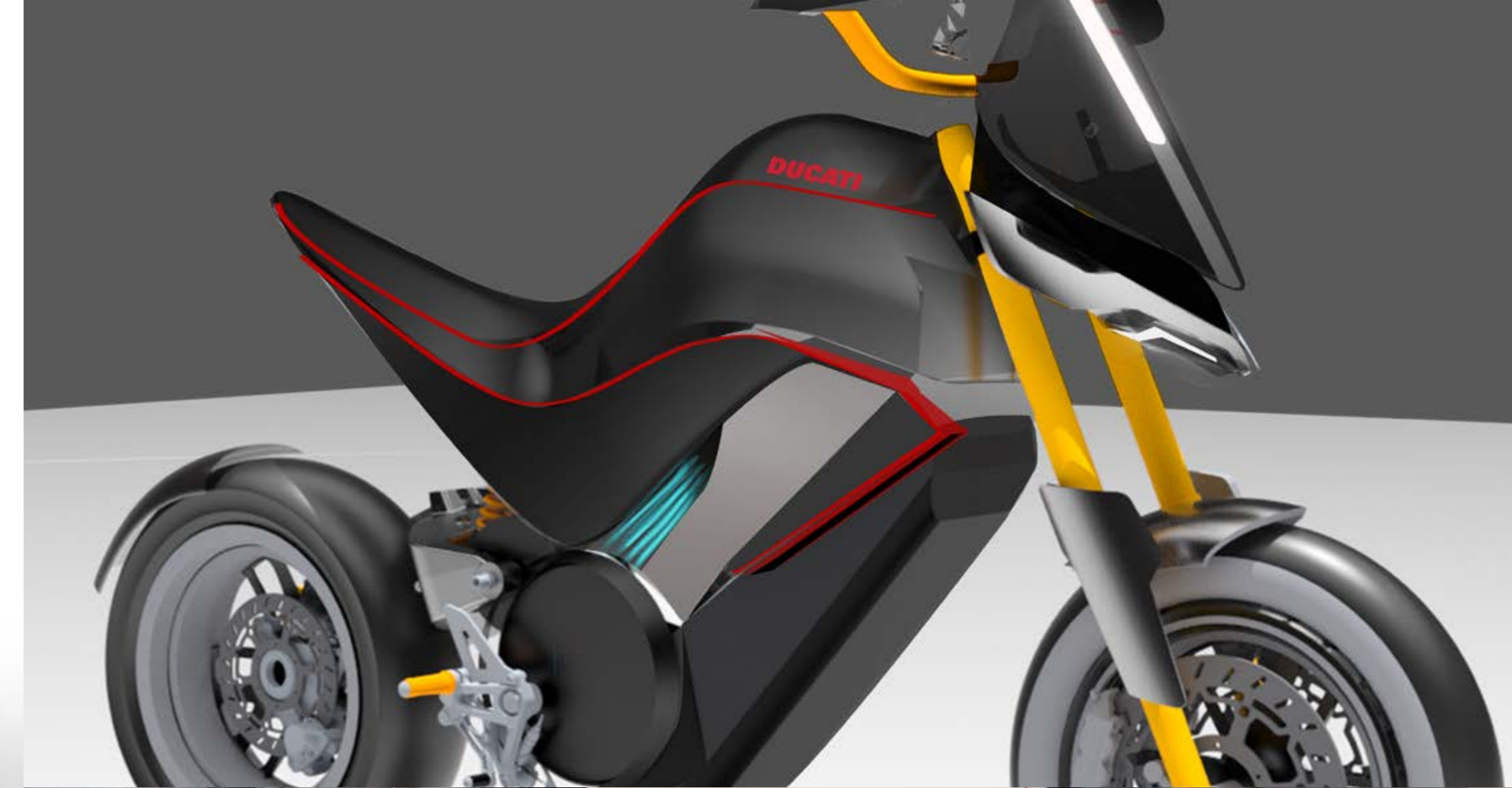
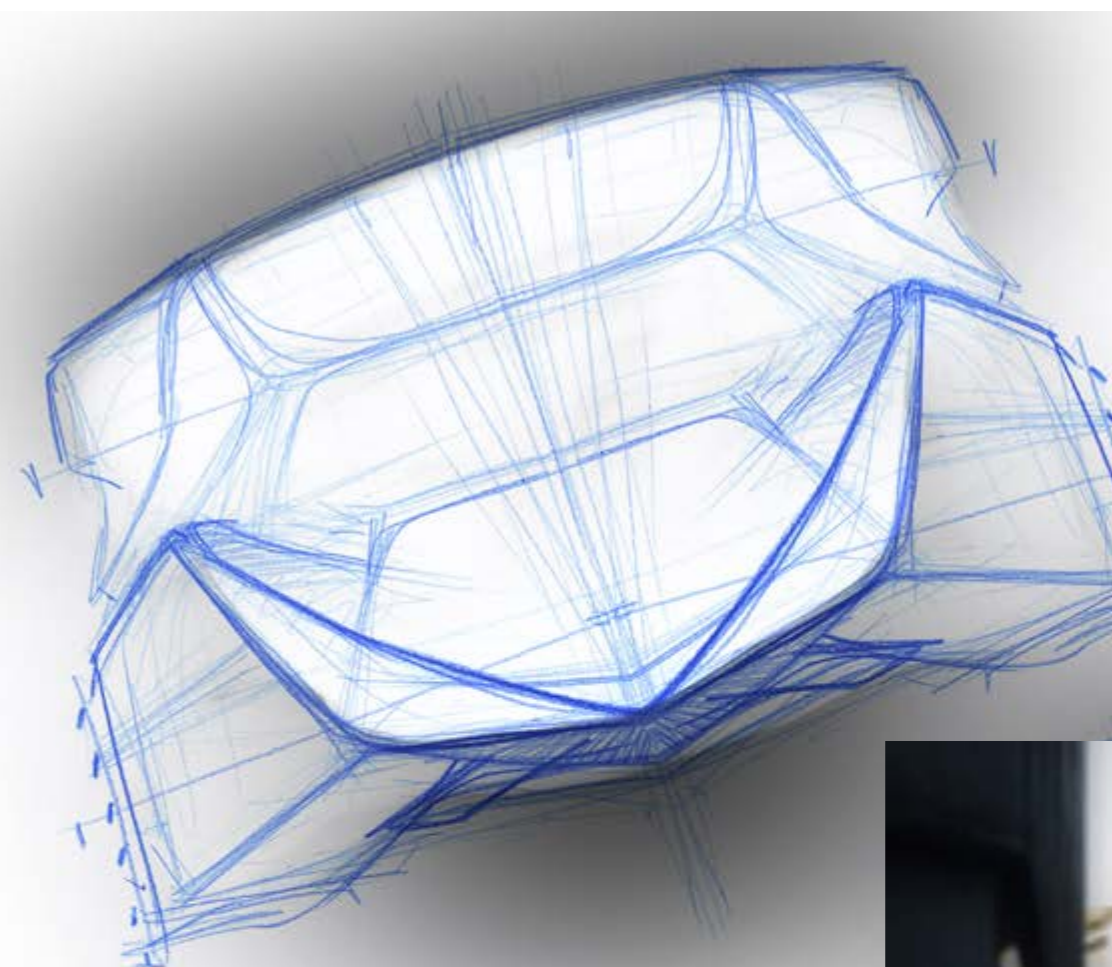

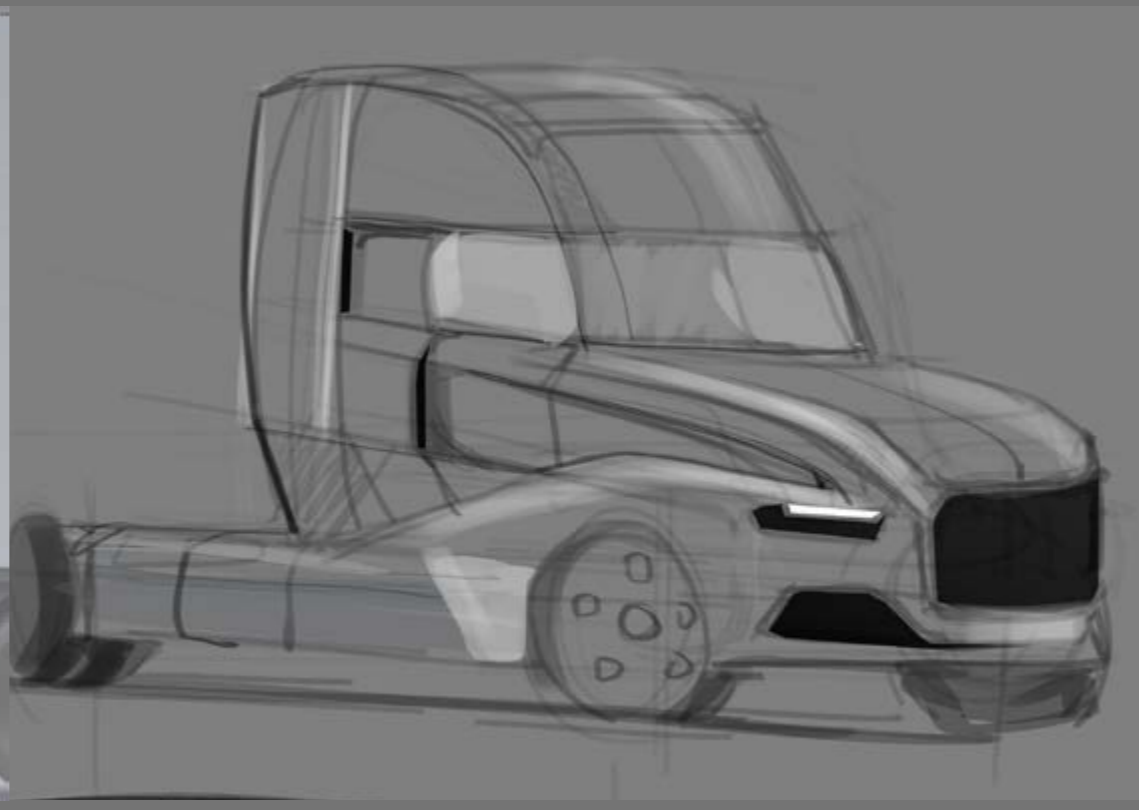
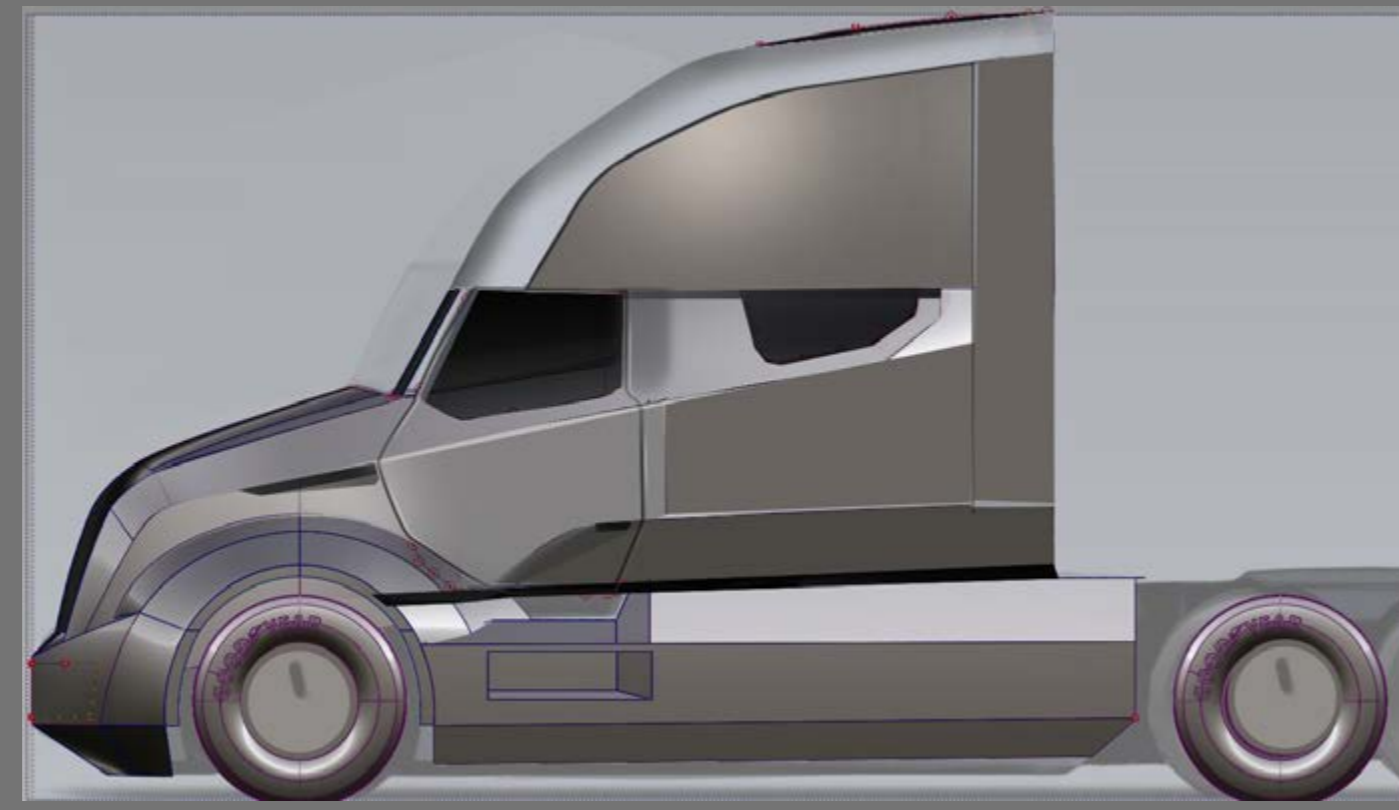
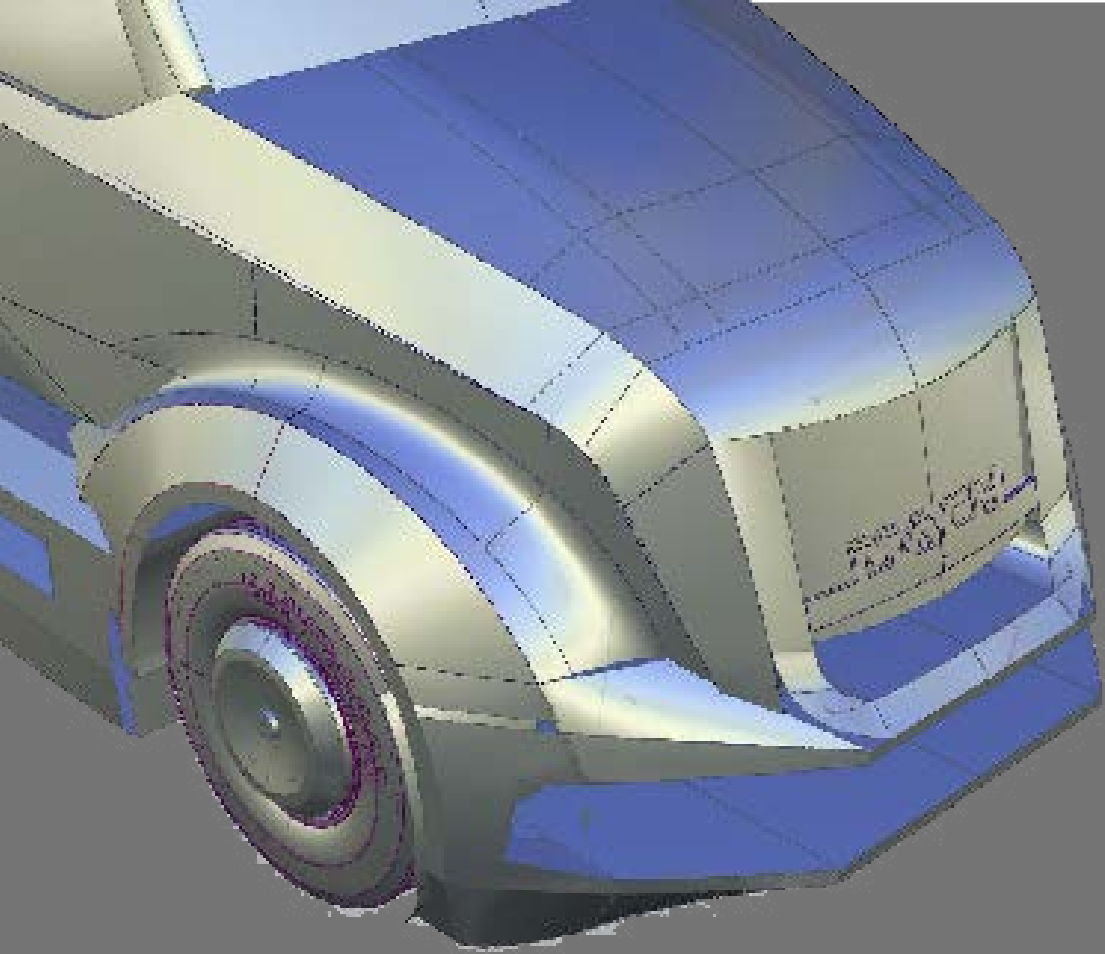

A fast Technique for Bézier surface helped to achieve quick shapes, This project was based on a scan of a Peterbilt 789 truck. images below are pre-filleted This project is for a new startup brand called Mach Motors for the American market for 2025.

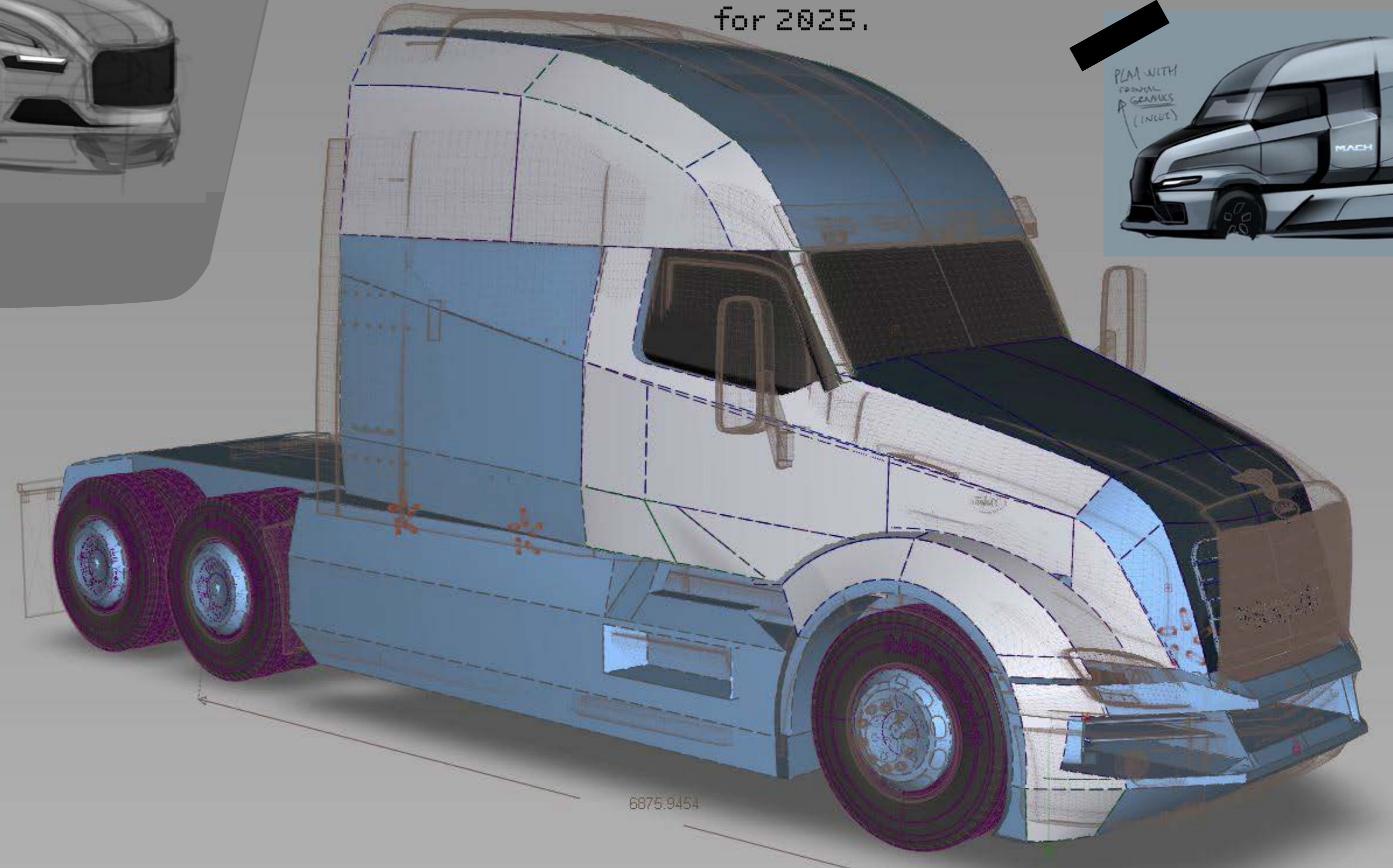
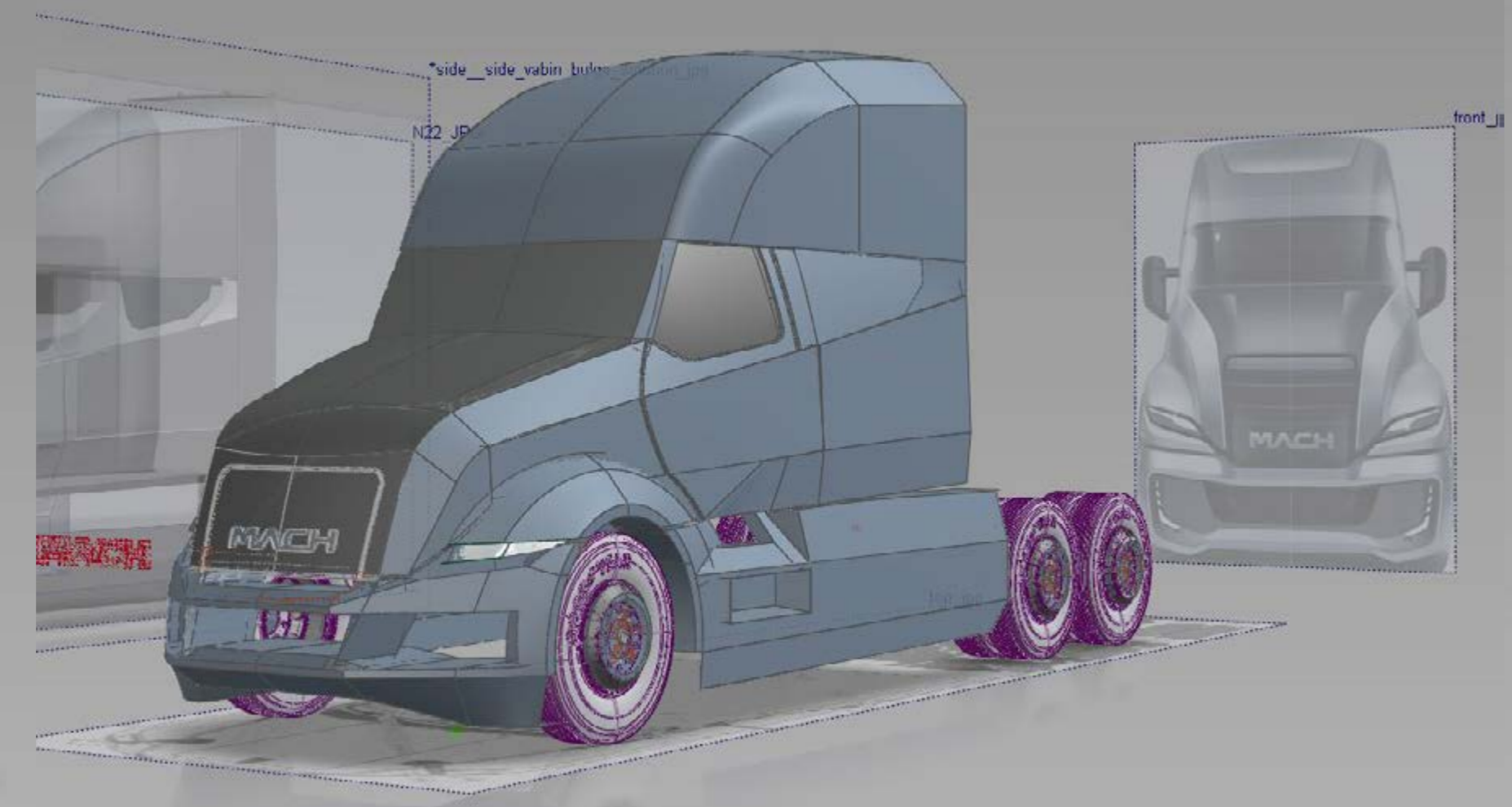
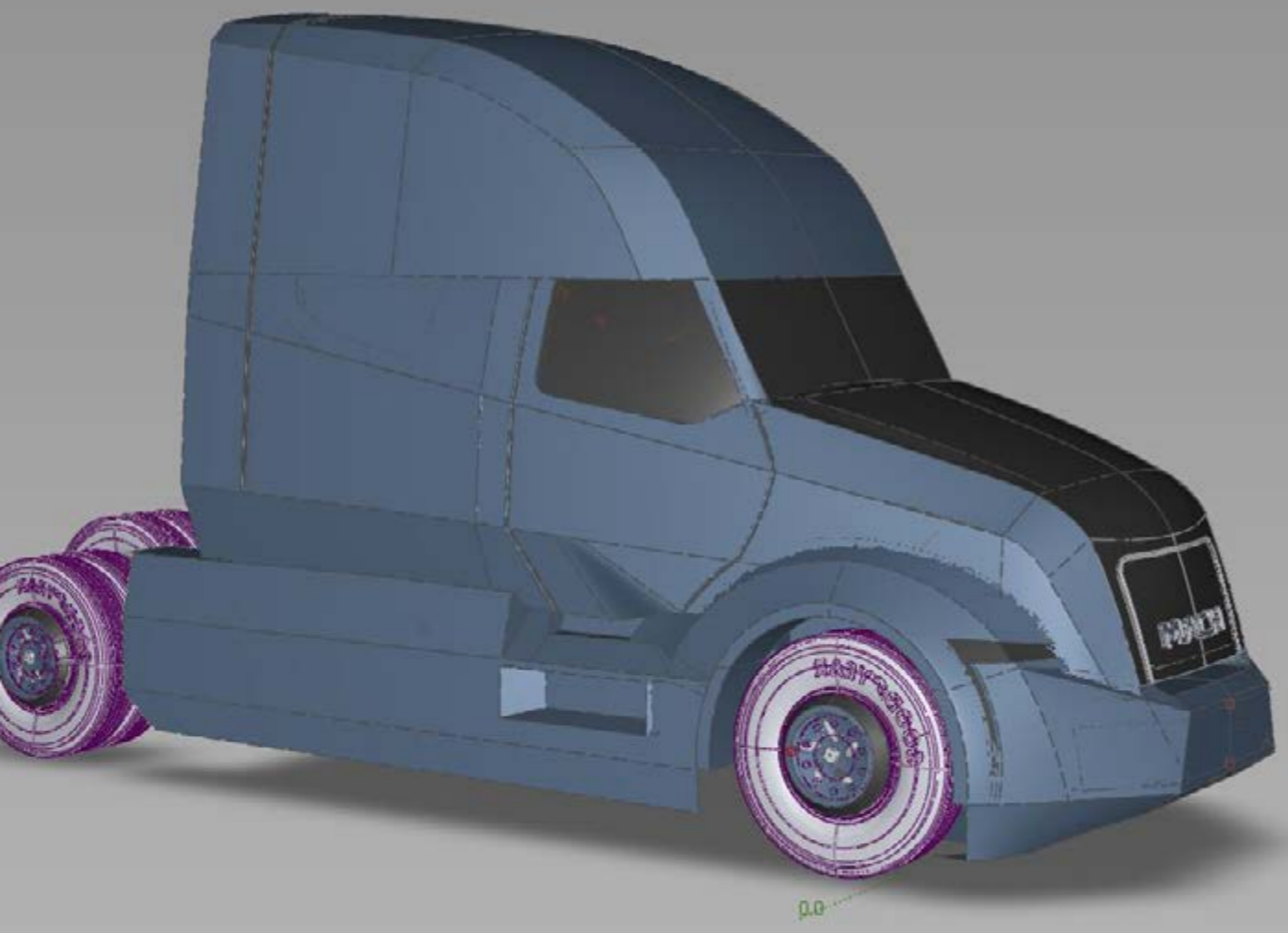

Package study :

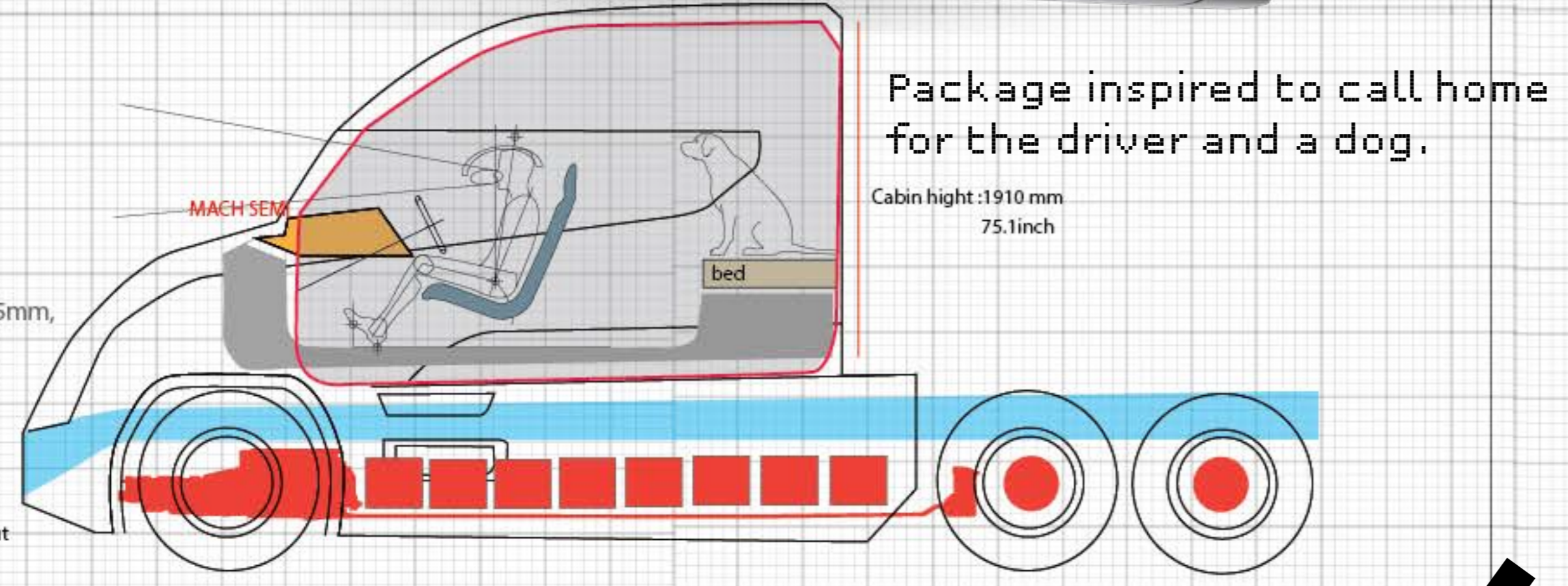
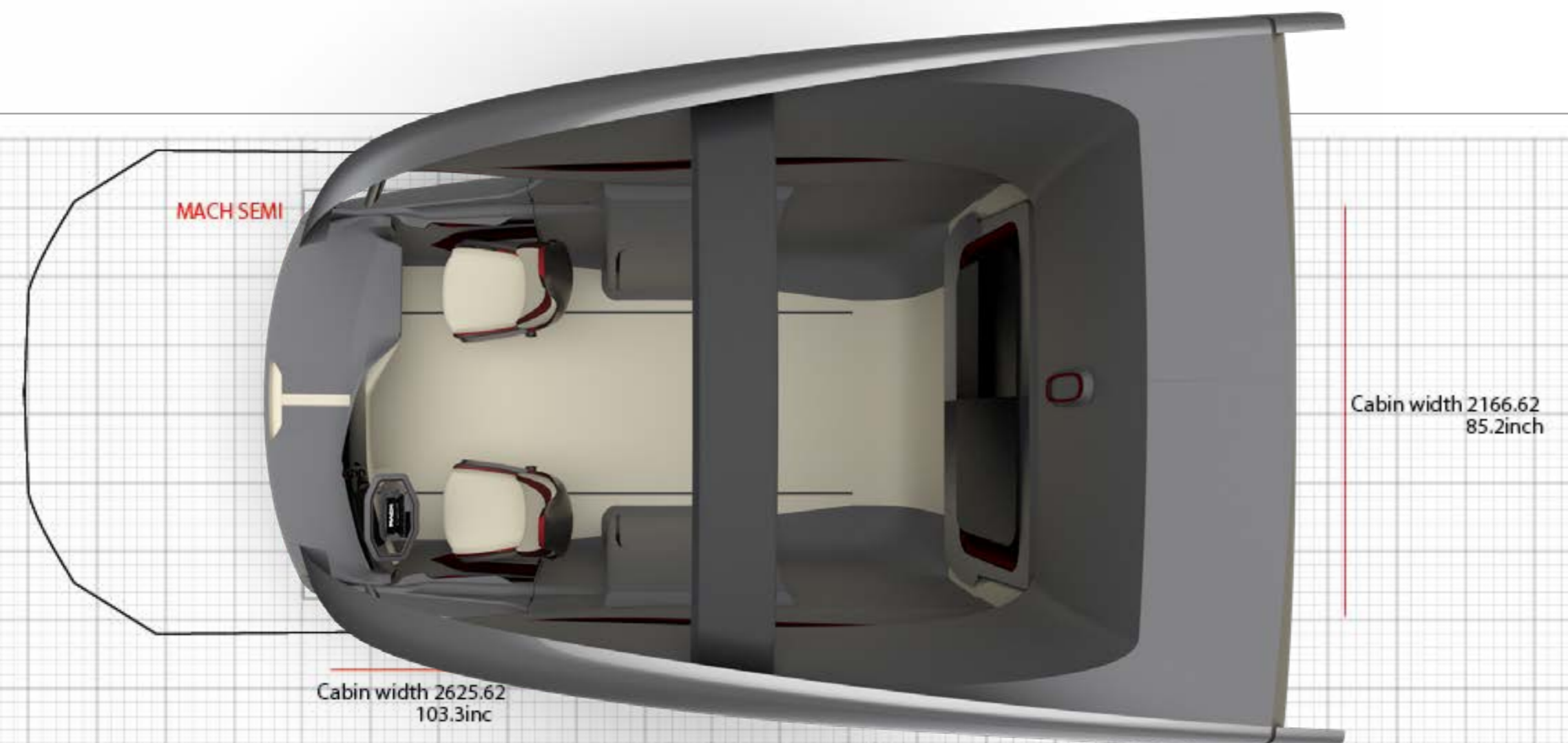

MACH | THRONE





Interior exploration, approach was to create a unique experience, yet familiar environment, the interior is a homage for early trucking in the 1900 with modern Tech influence.

MACH
THRONE

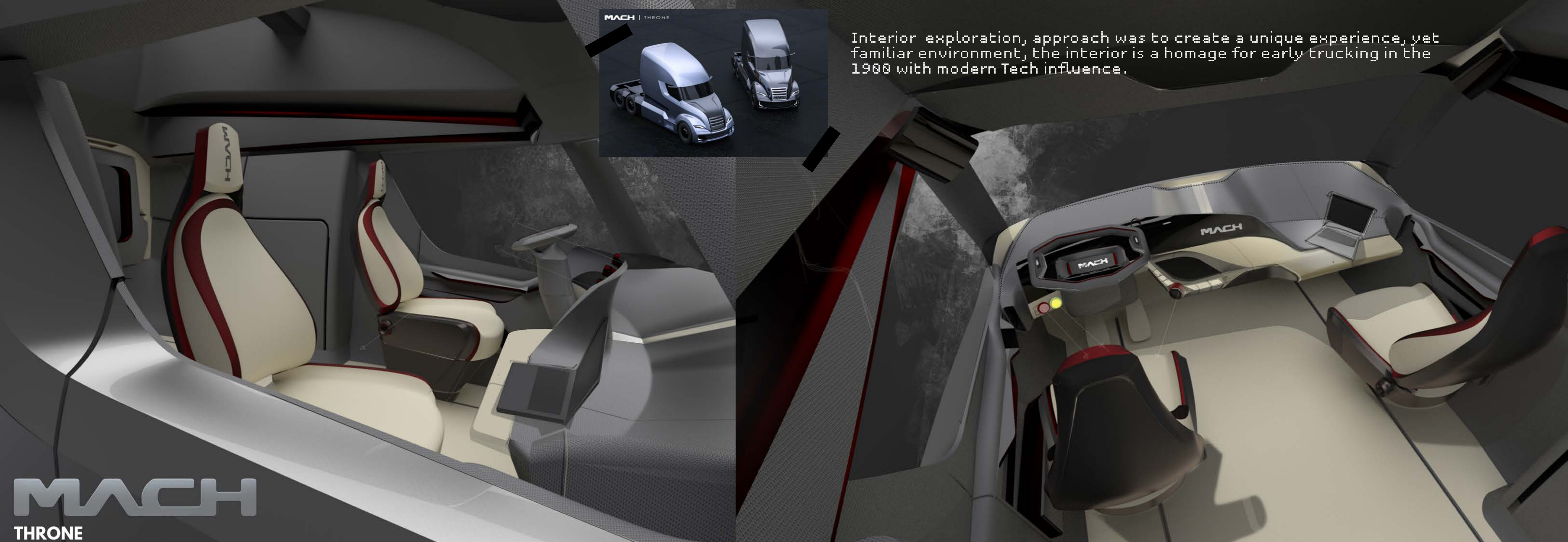

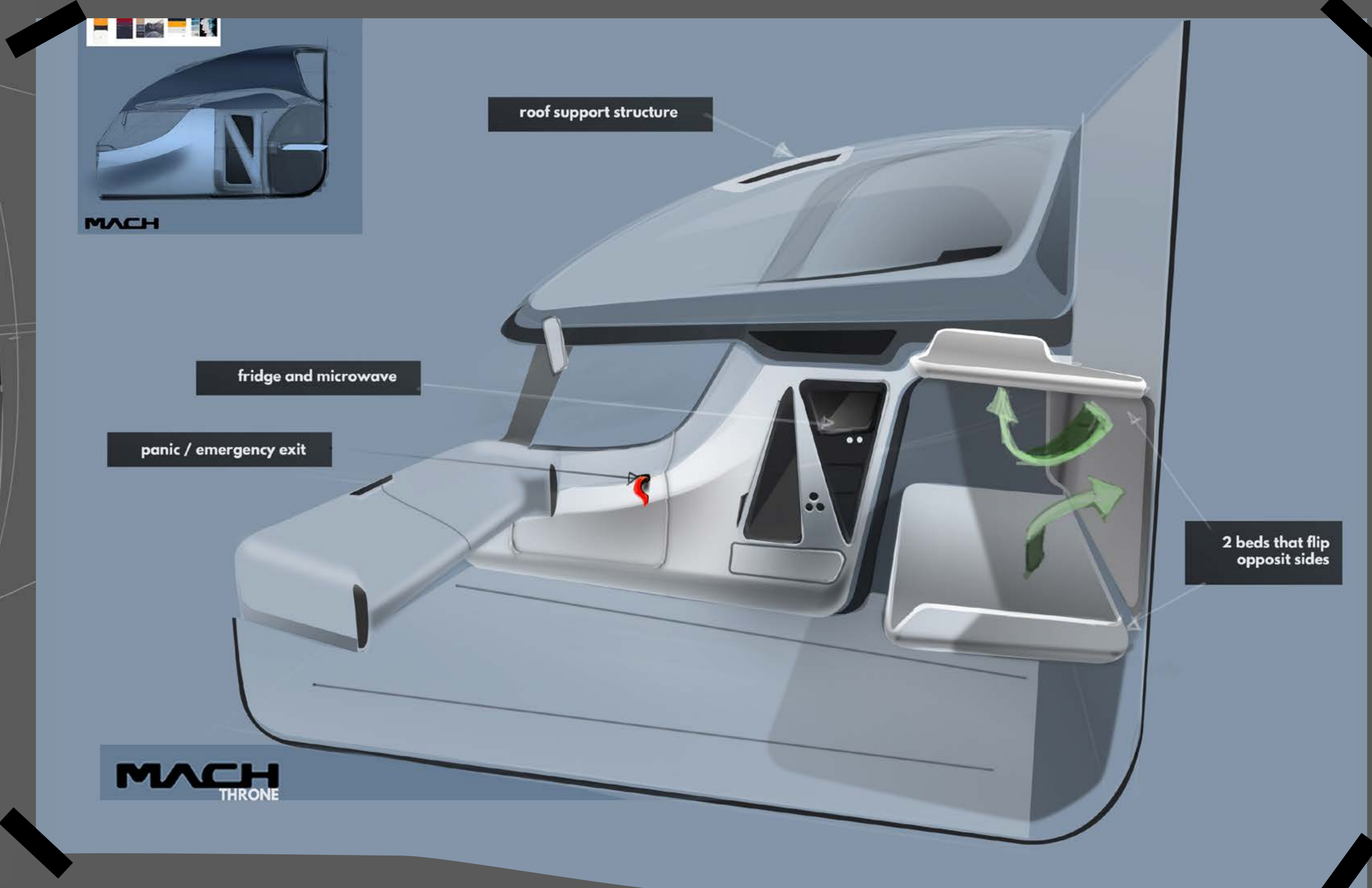
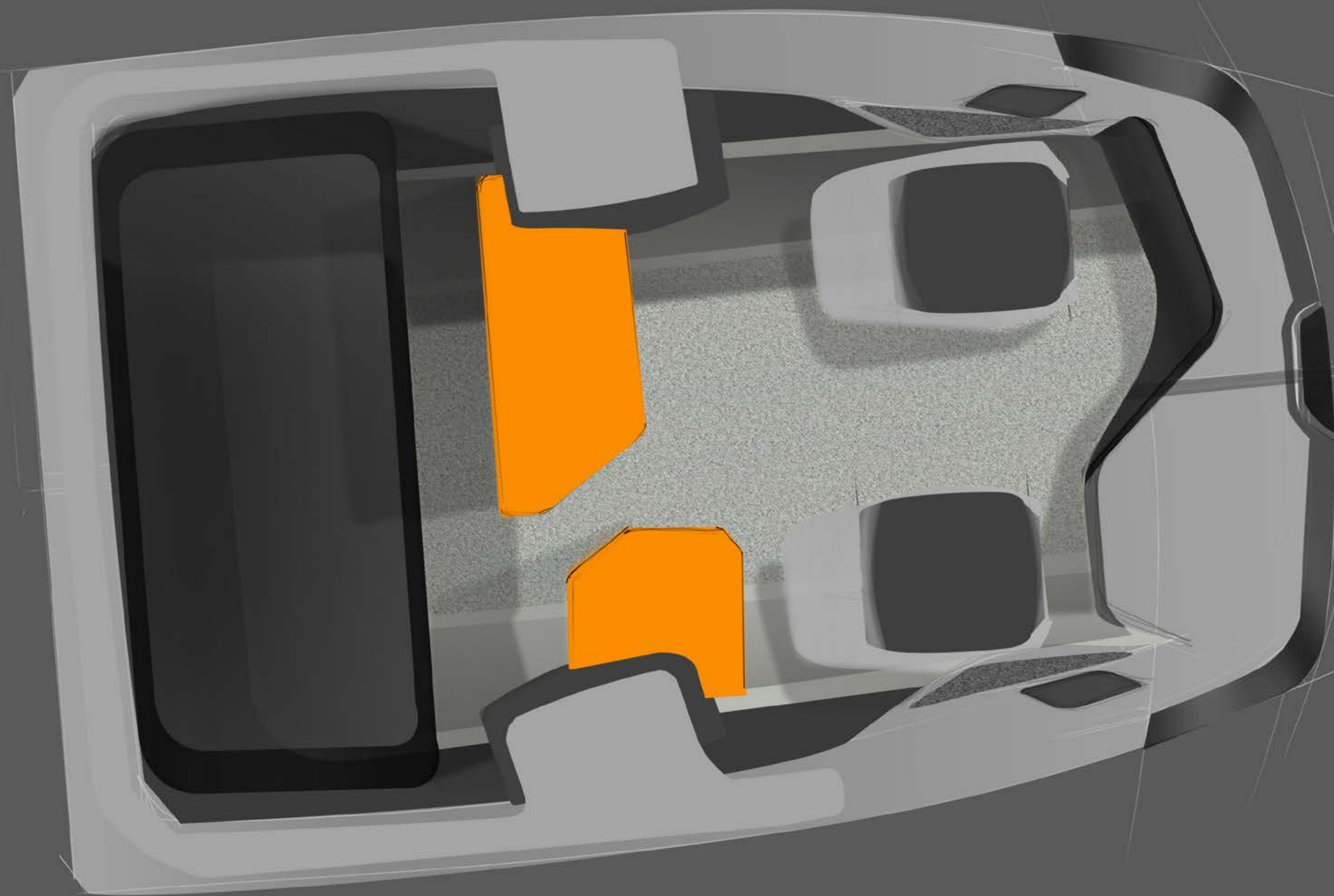

Responsability in this project was to support the team in making a decision based through process, that promotes users' self-sufficient, the right TABLE placement and manage the overall space inside the cabin.

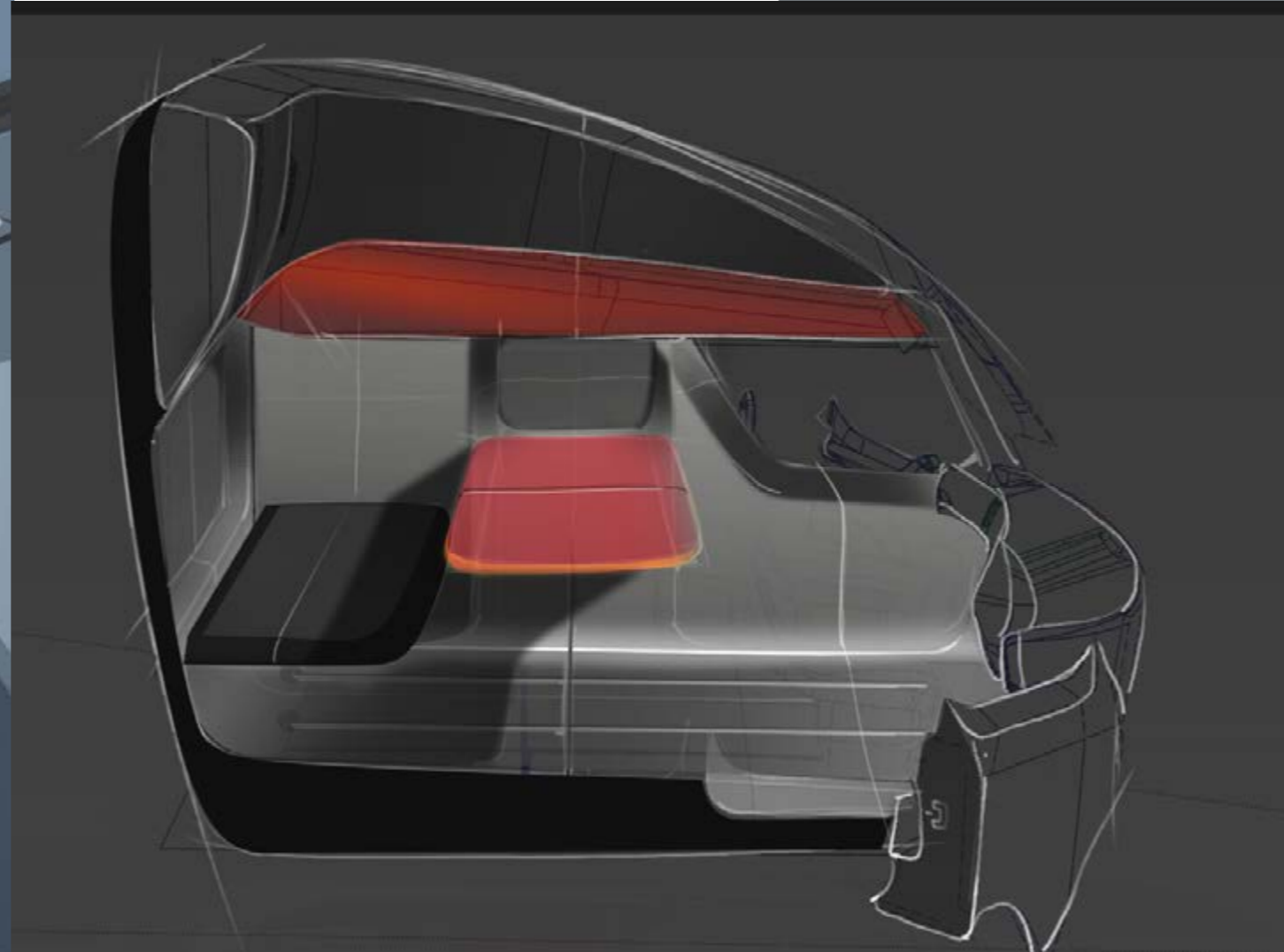
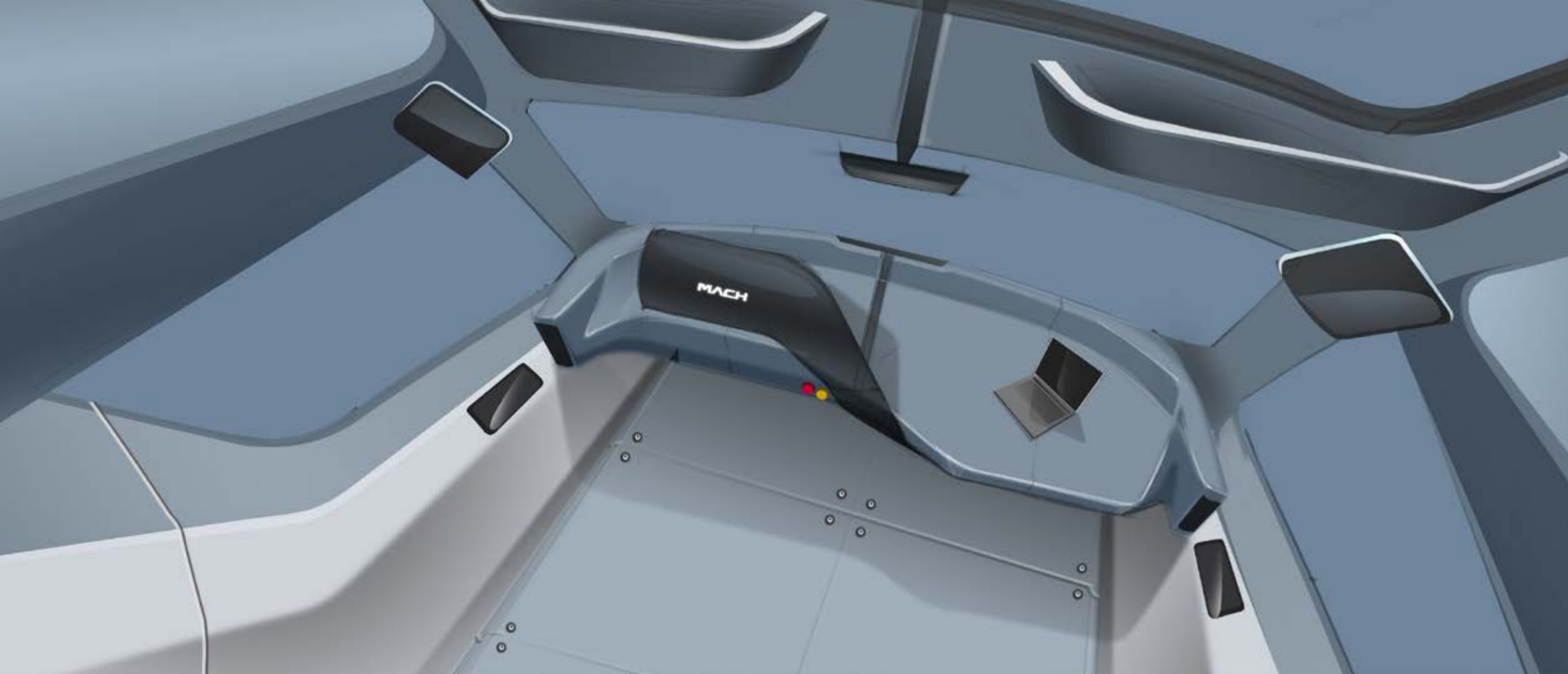

both interior and exterior design process have to match with the design philosophy of self-sufficiency and retro.

an aesthetic was needed to fulfill a traditional attitude in terms of C&T

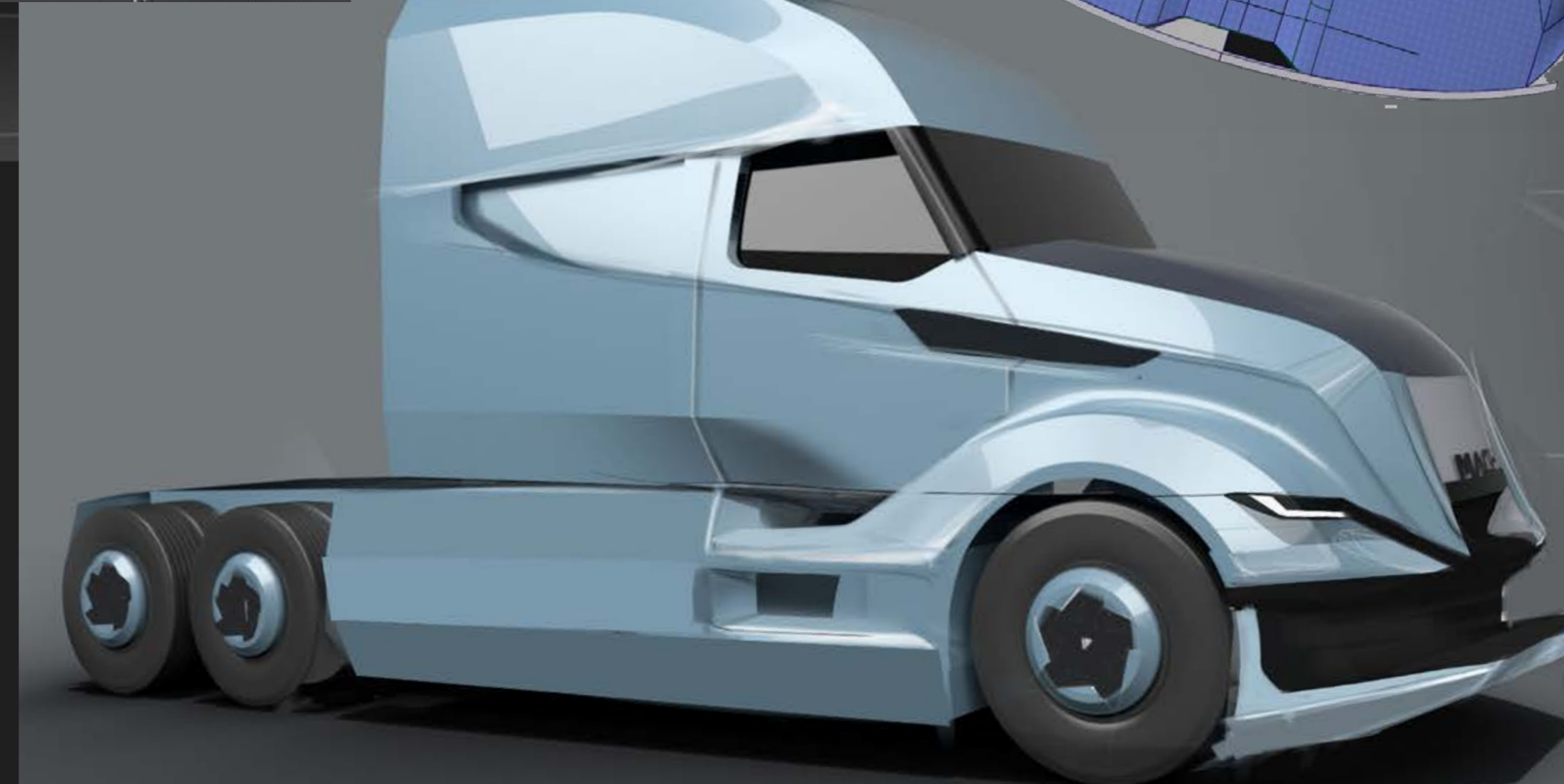
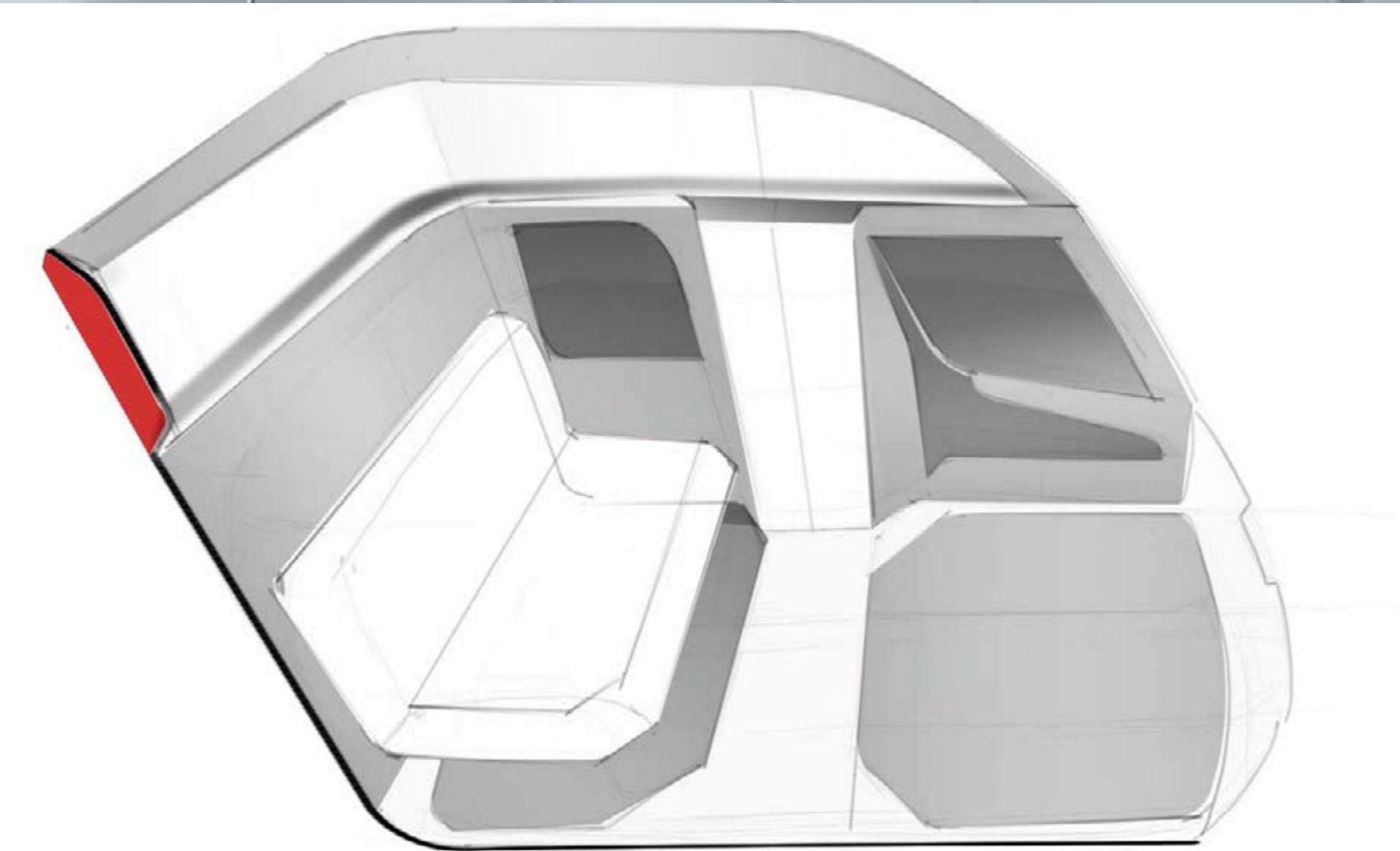

A poster to explain the interiors.

This was my major role in a team.

communication via compile and presentations to the decision-making team.

whilst working from home.



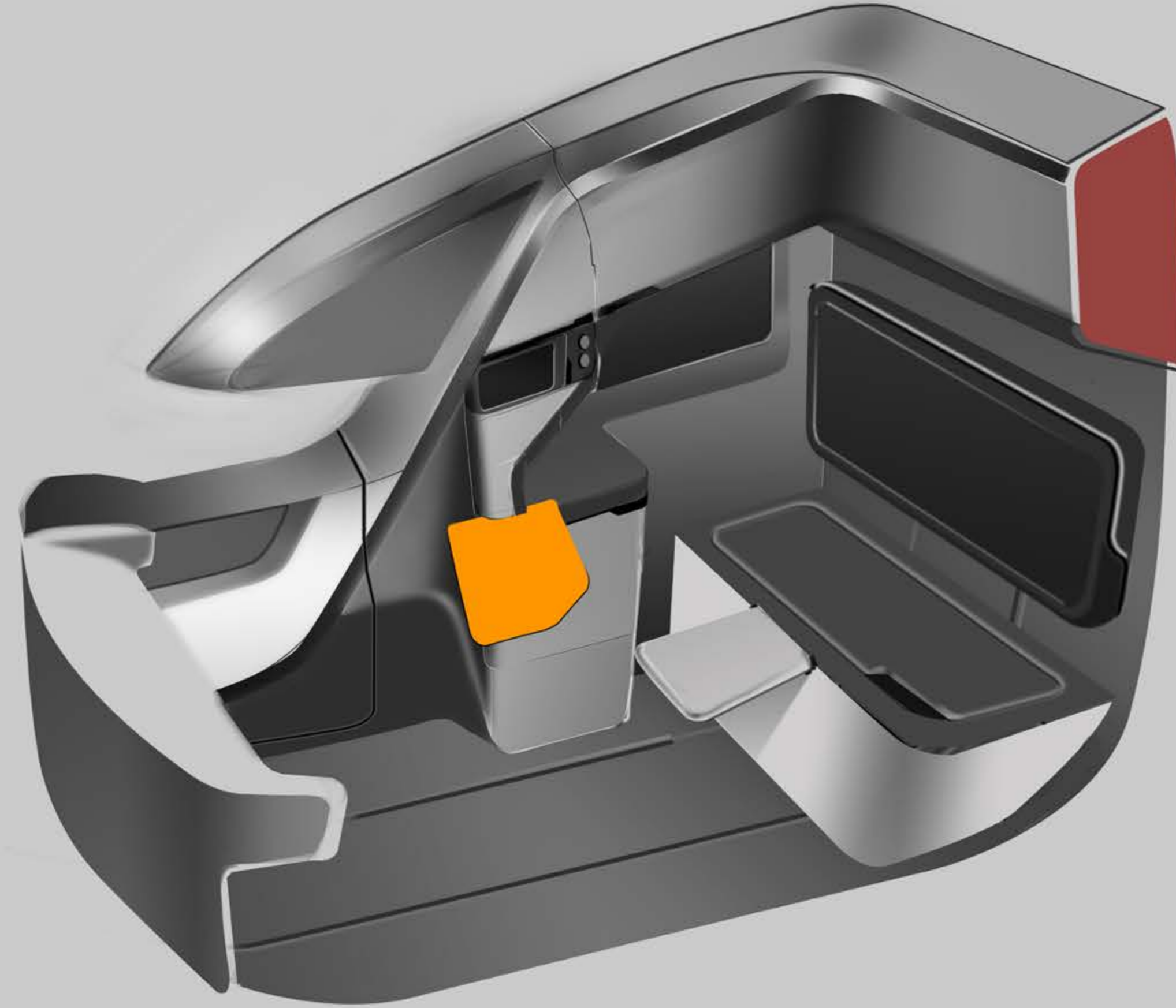
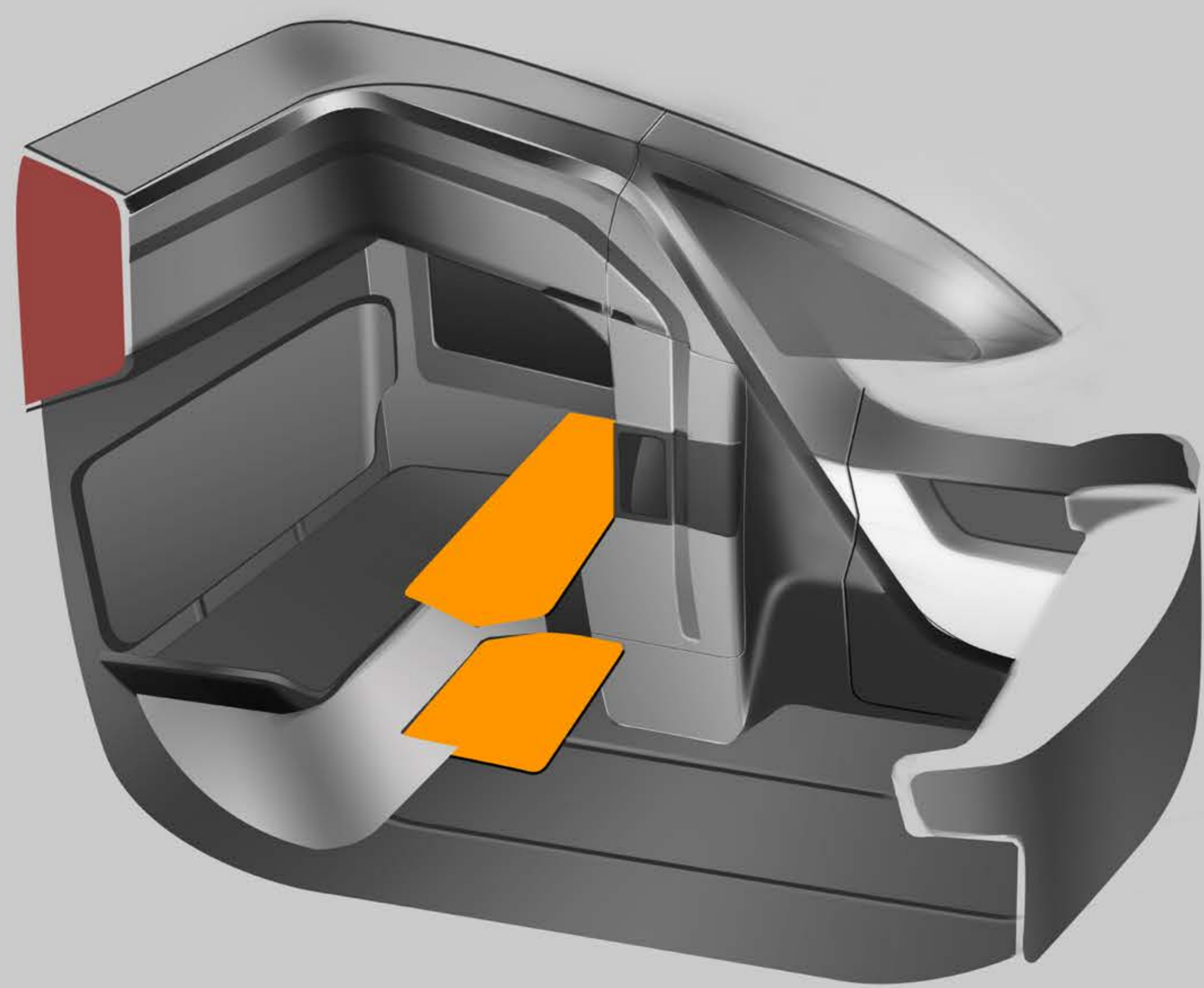

the project need an
approach of a motor
home,

where every corner
had to have a
purpose.

taking
inspiration from
Space

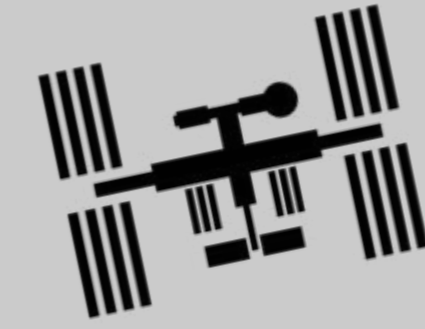

programs like the
ISS

utilize space as work
and
livable habitat

for an
extended
period of time.

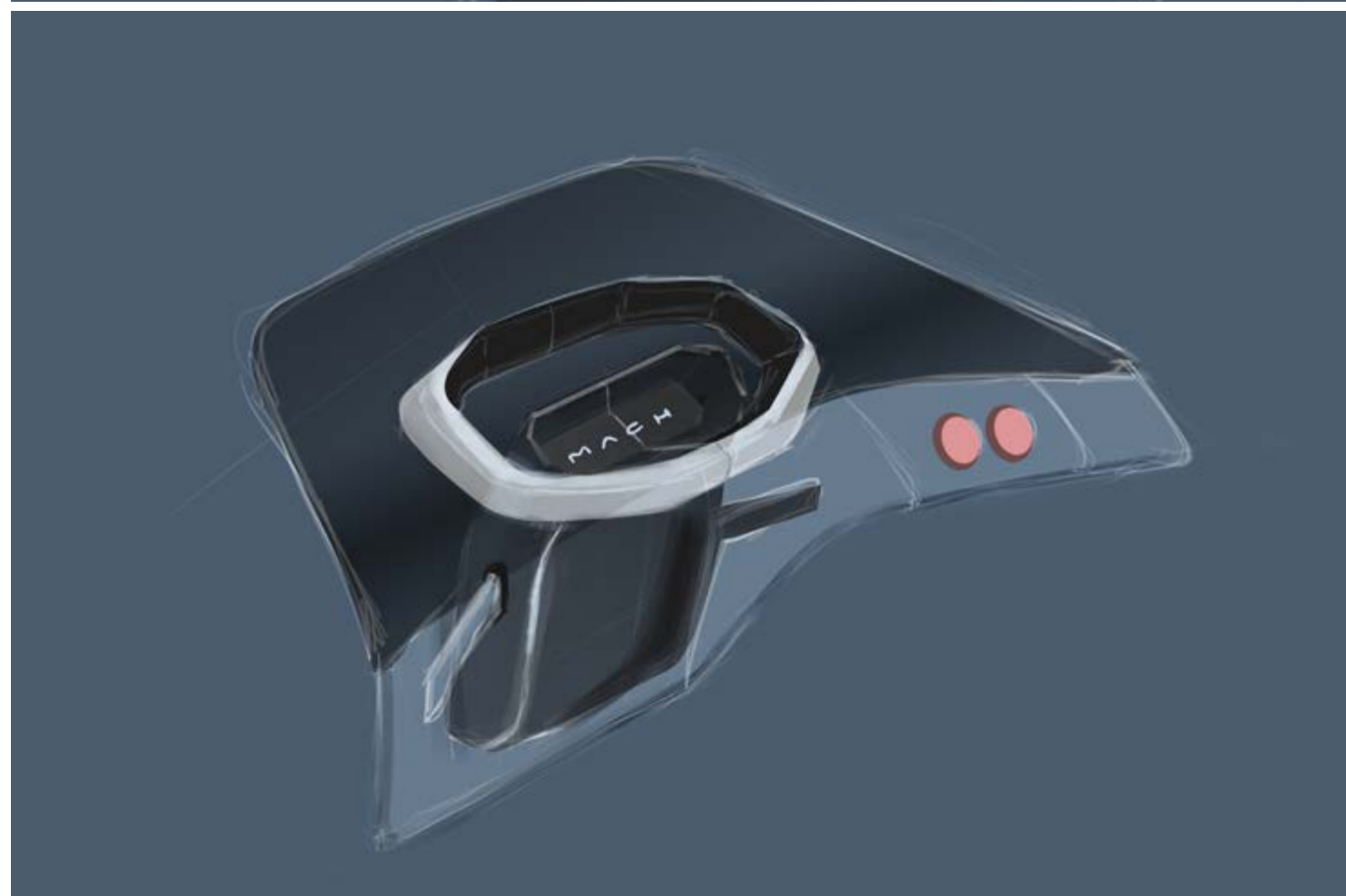
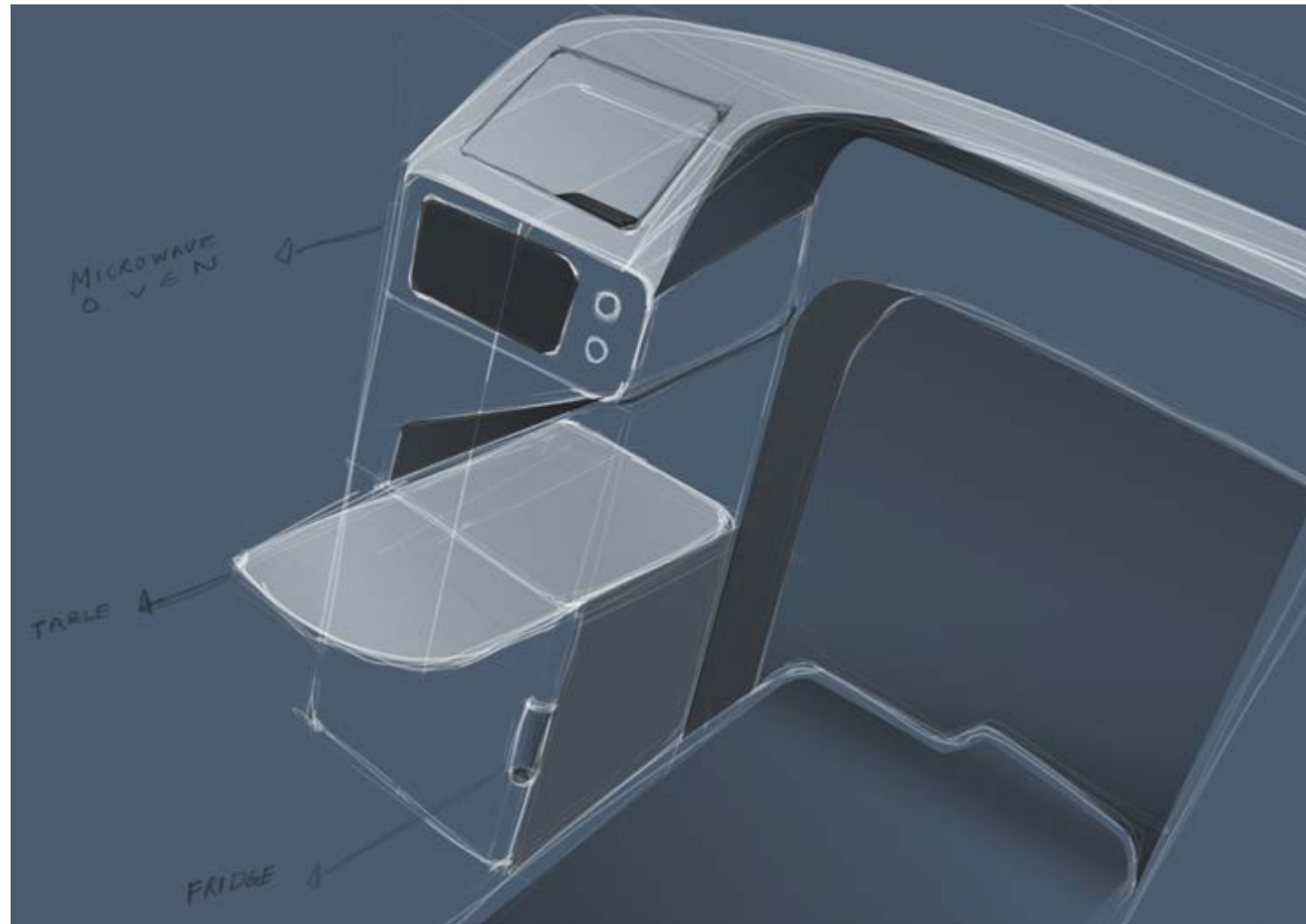

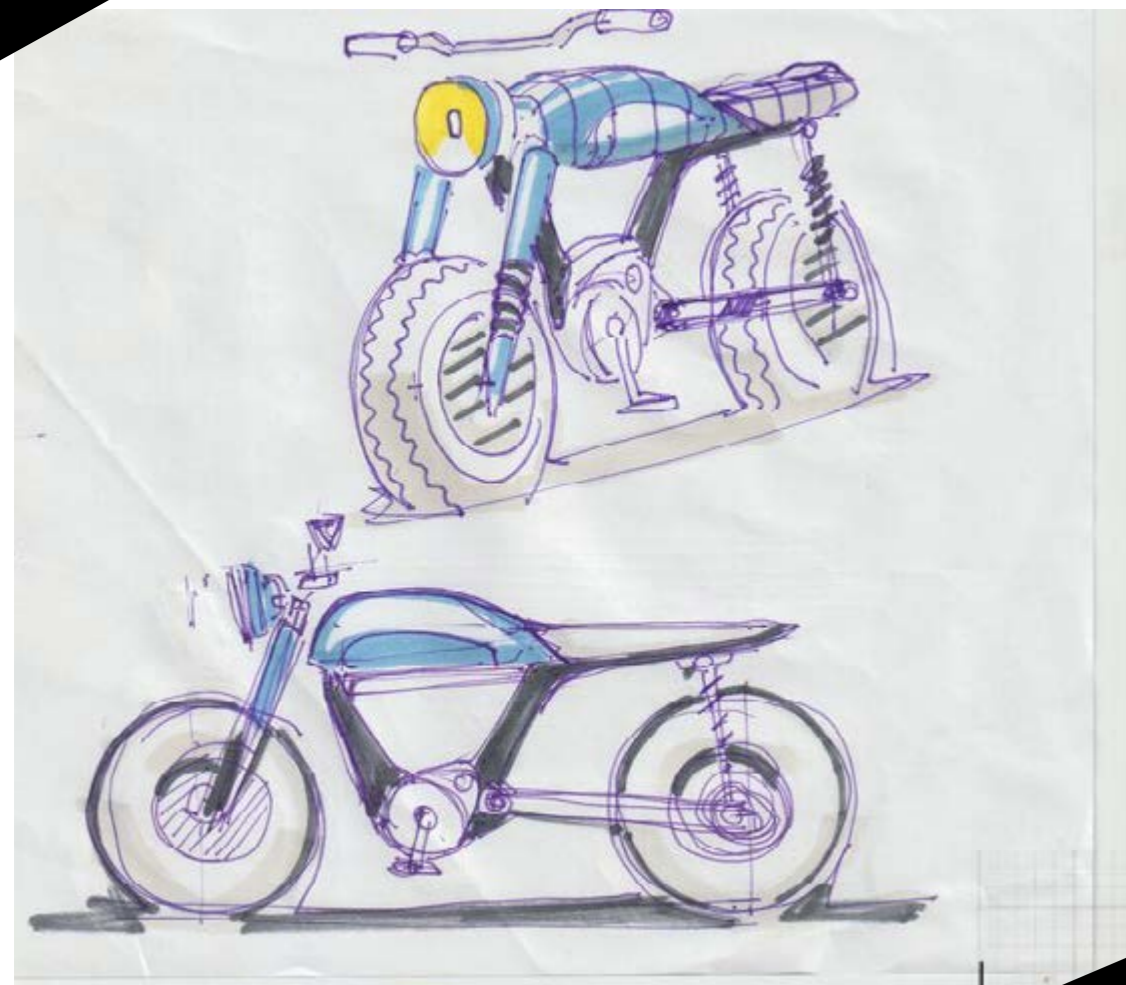

An ebike for indian cities

simplicity as a purpose.

A Ebike made with off-the shelf components.

lower the cost to 25000 inr

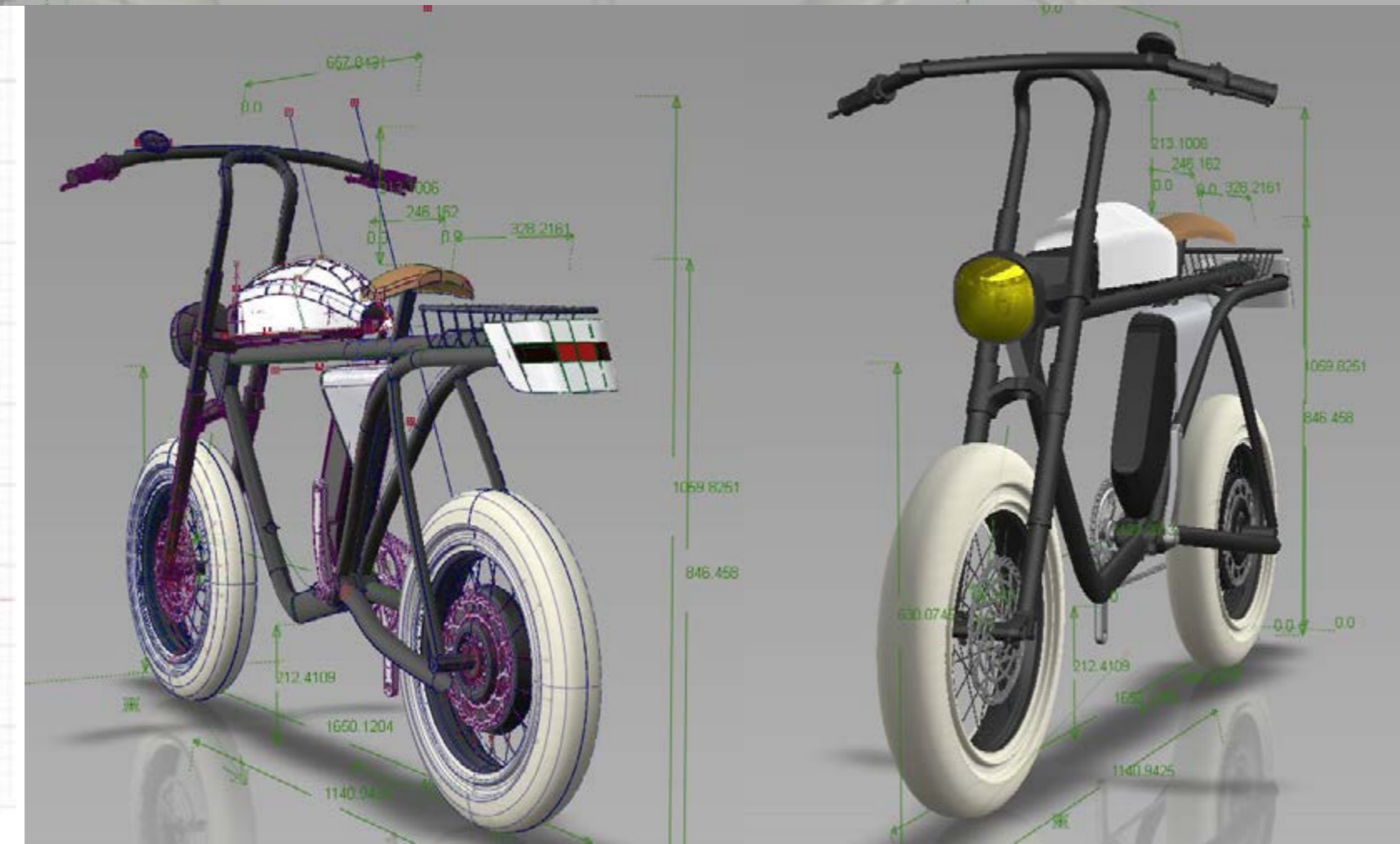
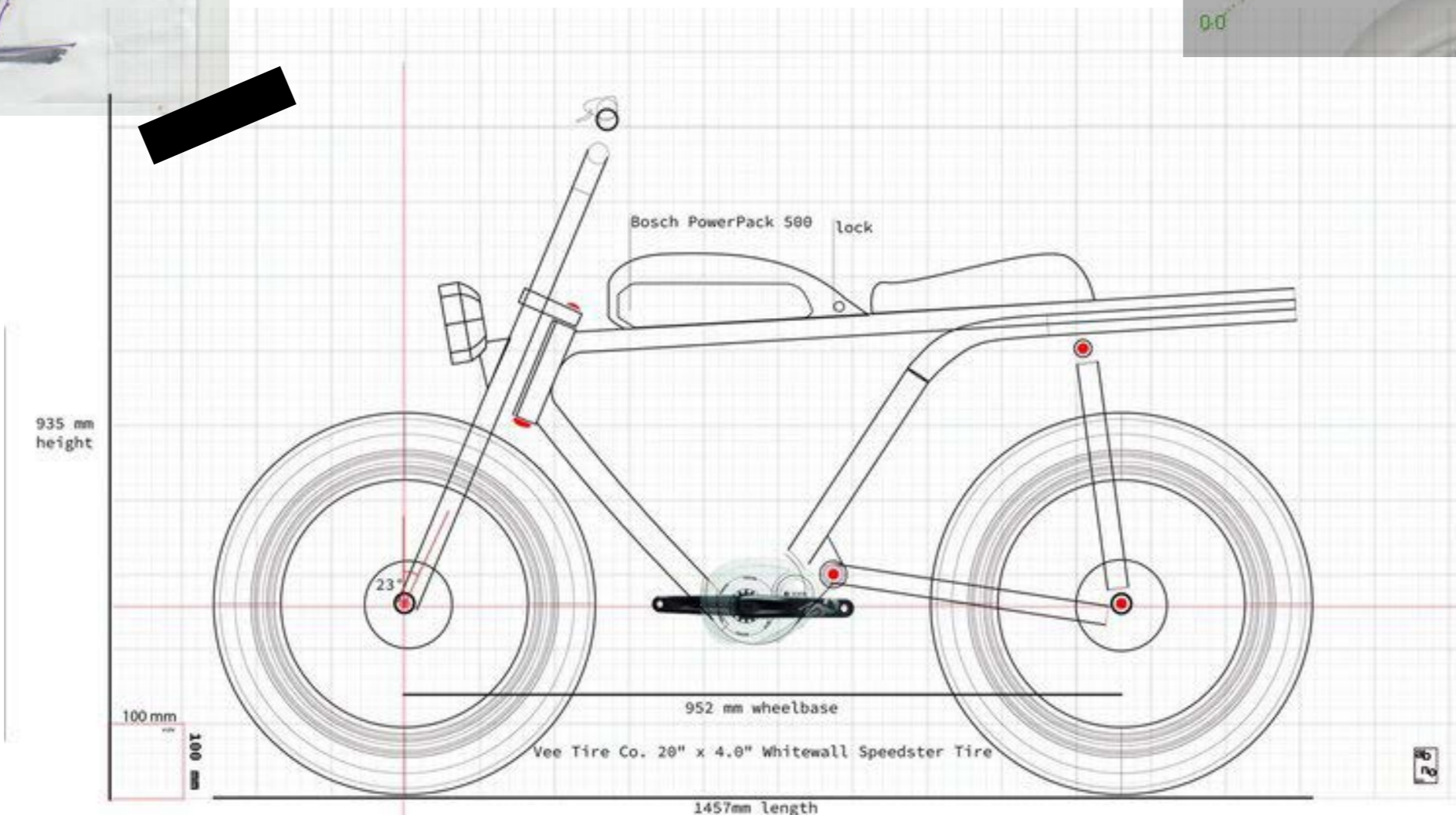
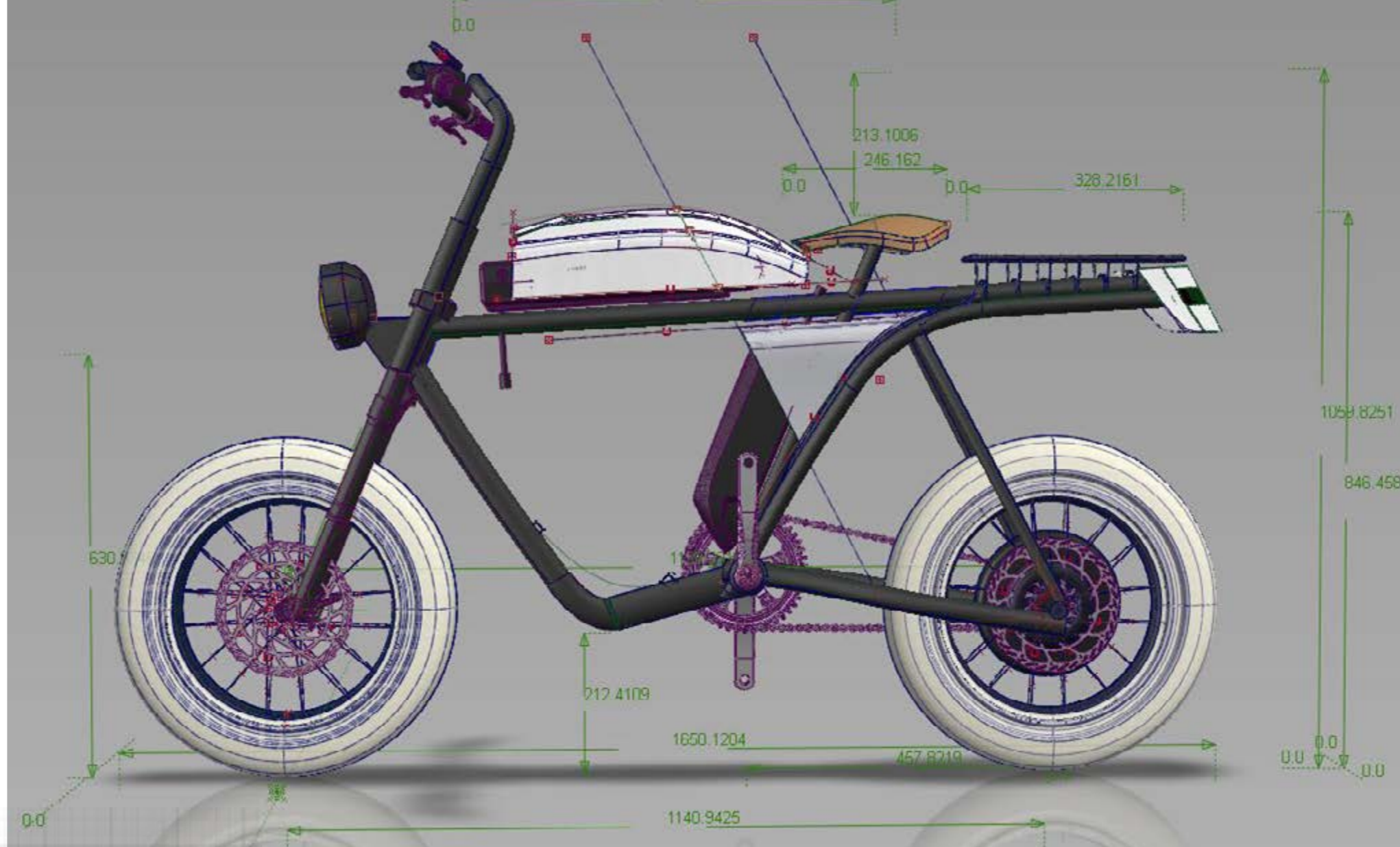

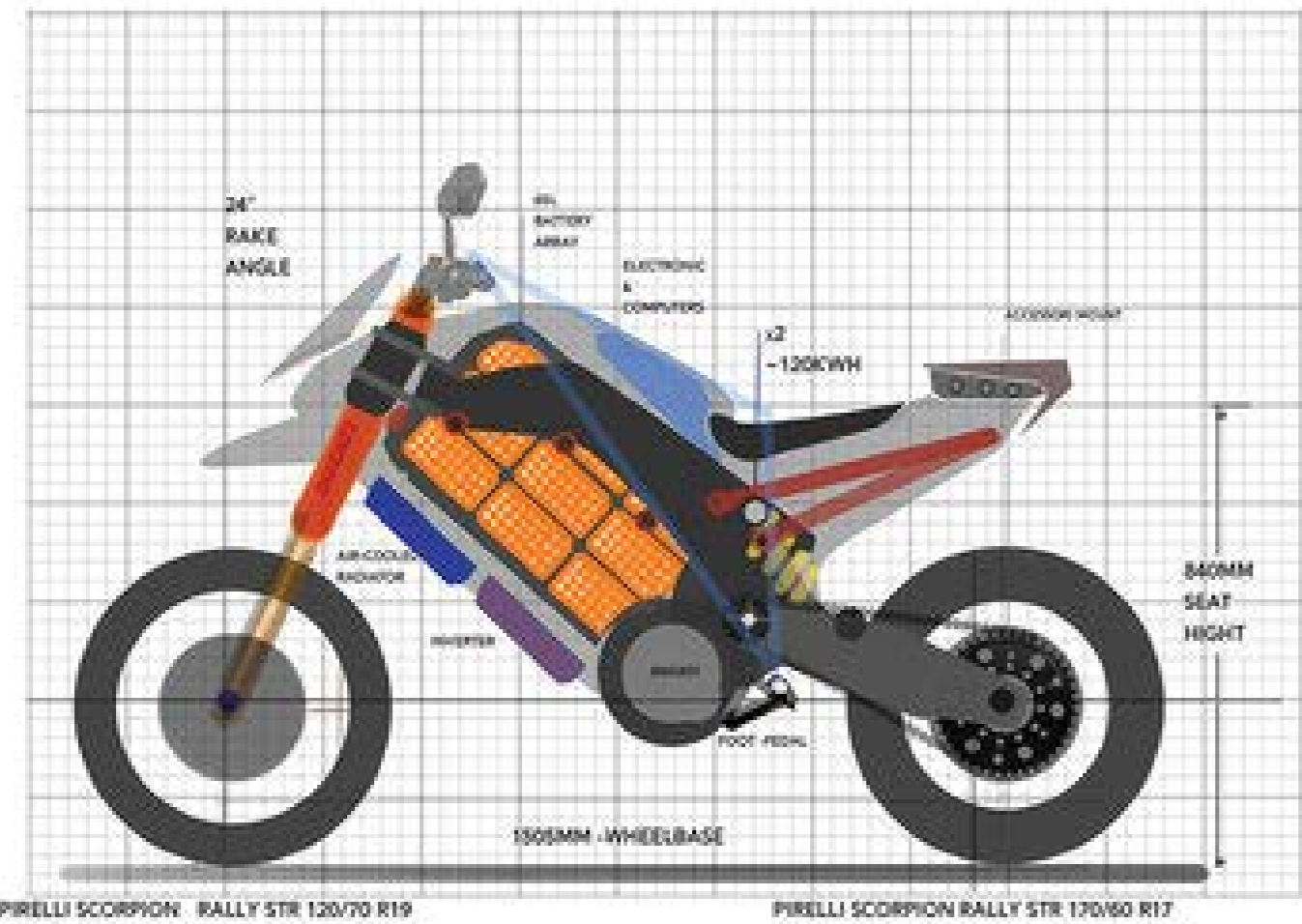

Ducati light city electric bike

packaging of a E-bike for a new generation.

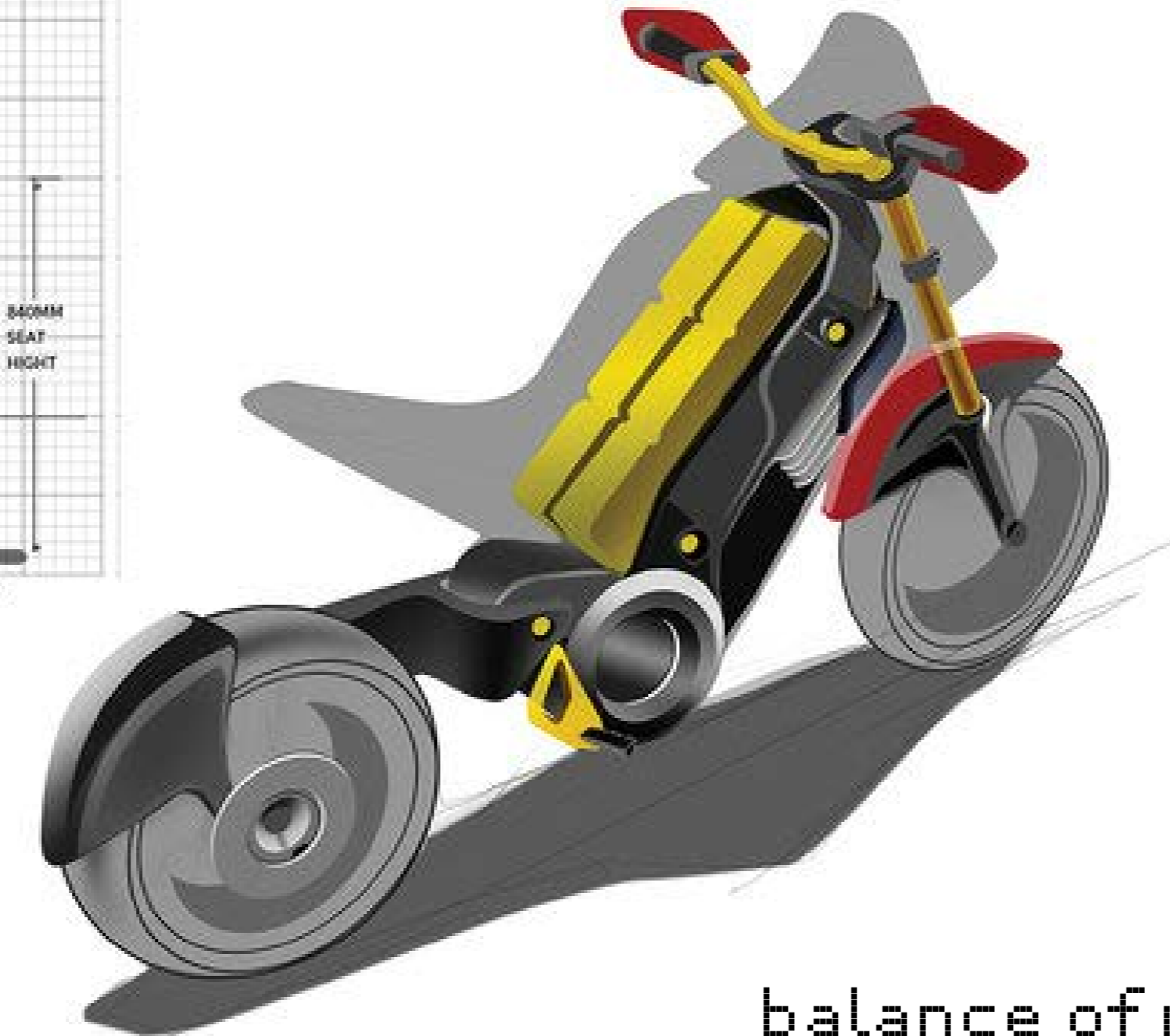

// "A lighter Supermoto type

balance of package and aesthetics//



Colour Palette

1	2	3	4	5
0 95 94 28	69 53 46 22	47 73 48 67	0 19 79 0	100 0 38 2
6	7	8	9	
4 2 4 8	23 16 13 46	40 30 20 66	0 0 0 94	



- A** **Material:** Aluminum
Finishing: Combination of satin and high gloss
Process: Anodization
Color: PANTONE 19-4517 TPG (69-53-46-22)
Accent: PANTONE 7620 C (0 95 94 28)
- B** **Material:** High-density fibre polymer or high-density Hemp
Finishing: Textured hard fabric
Color: PANTONE Cool Gray 10 C and 9 C (CMYK 40 30 20 66) (CMYK 0 0 0 94)
- C** **Material:** Aluminum and magnesium
Process: Metal forge
Finishing: Gloss, Power finish.
Color: PANTONE 1225 C (0 19 79 0)
- D** **Material:** CNC Aluminum/hard plastic - Anodizing/powder coated
Process: CNC milling
Finishing: Anodized Matte/ powder finish.
Color: PANTONE Cool Gray 8 C (CMYK 23 16 13 46)



- E** **Material:** Softwood and foam
Process: Natural wood pressed with foam
Finishing: Dark Smooth Walnut
Color: PANTONE 2478 C (47 73 48 67)
- F** **Material:** Aluminum sintered powder
Process: Additive manufacturing
Finishing: Raw sintering finishing
Color: PANTONE Cool Gray 8 C (23 16 13 46)
- G** **Material:** Hard ABS Plastic
Process: Injection Moulding
Finishing: Gloss
Color: PANTONE Cool Gray 1 C (4 2 4 8)
- H** **Material:** Coring glass
Finishing: Gloss
Color: PANTONE Cool Gray 10 C (40 30 20 66)
- I** **Material:** Translucent Film
Finishing: Translucent gloss
Color: PANTONE 19-4517 TPG (100 0 38 2)

C&T poster for material choice



minimum surfaces
approch (3x3 cv)

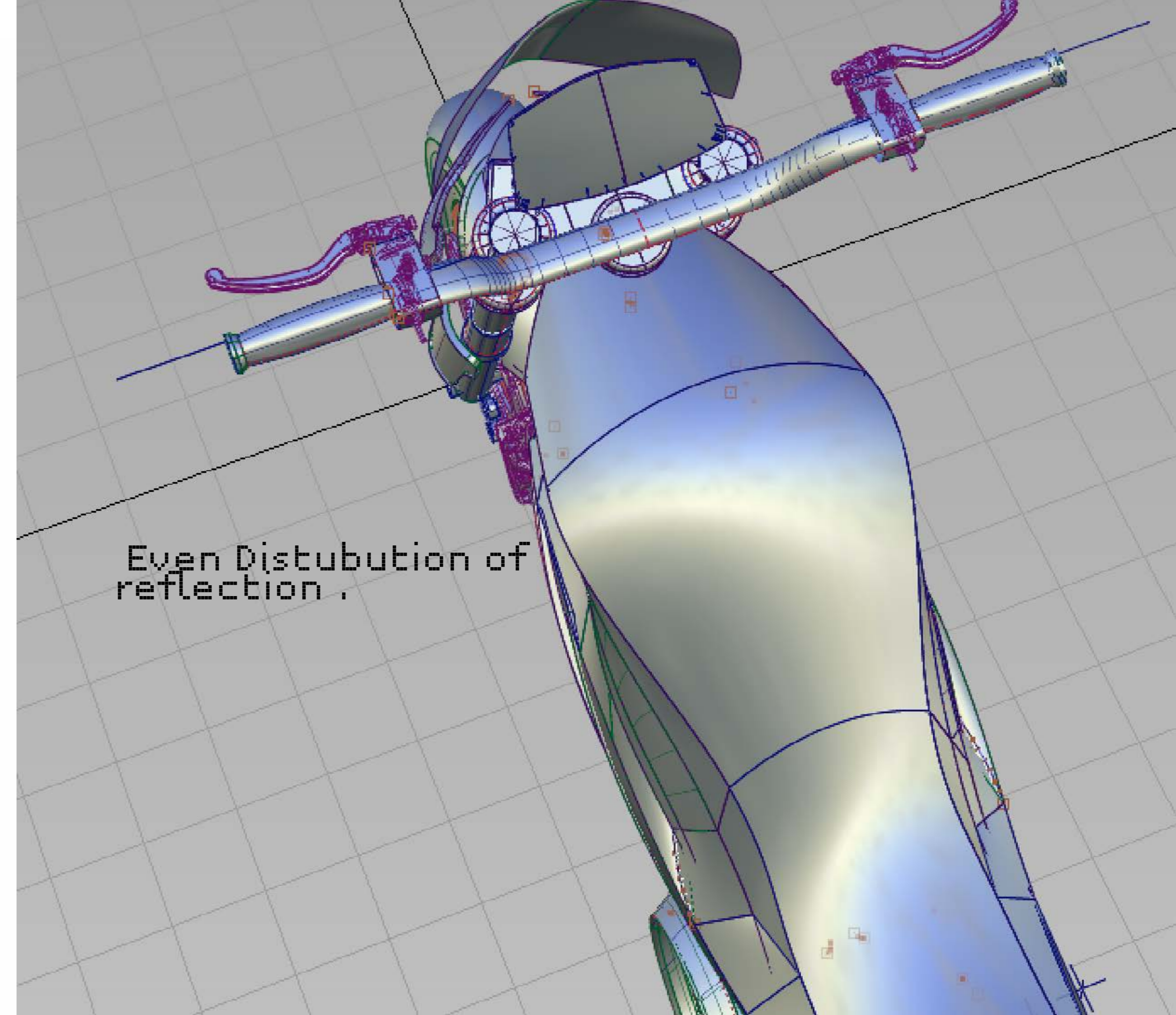
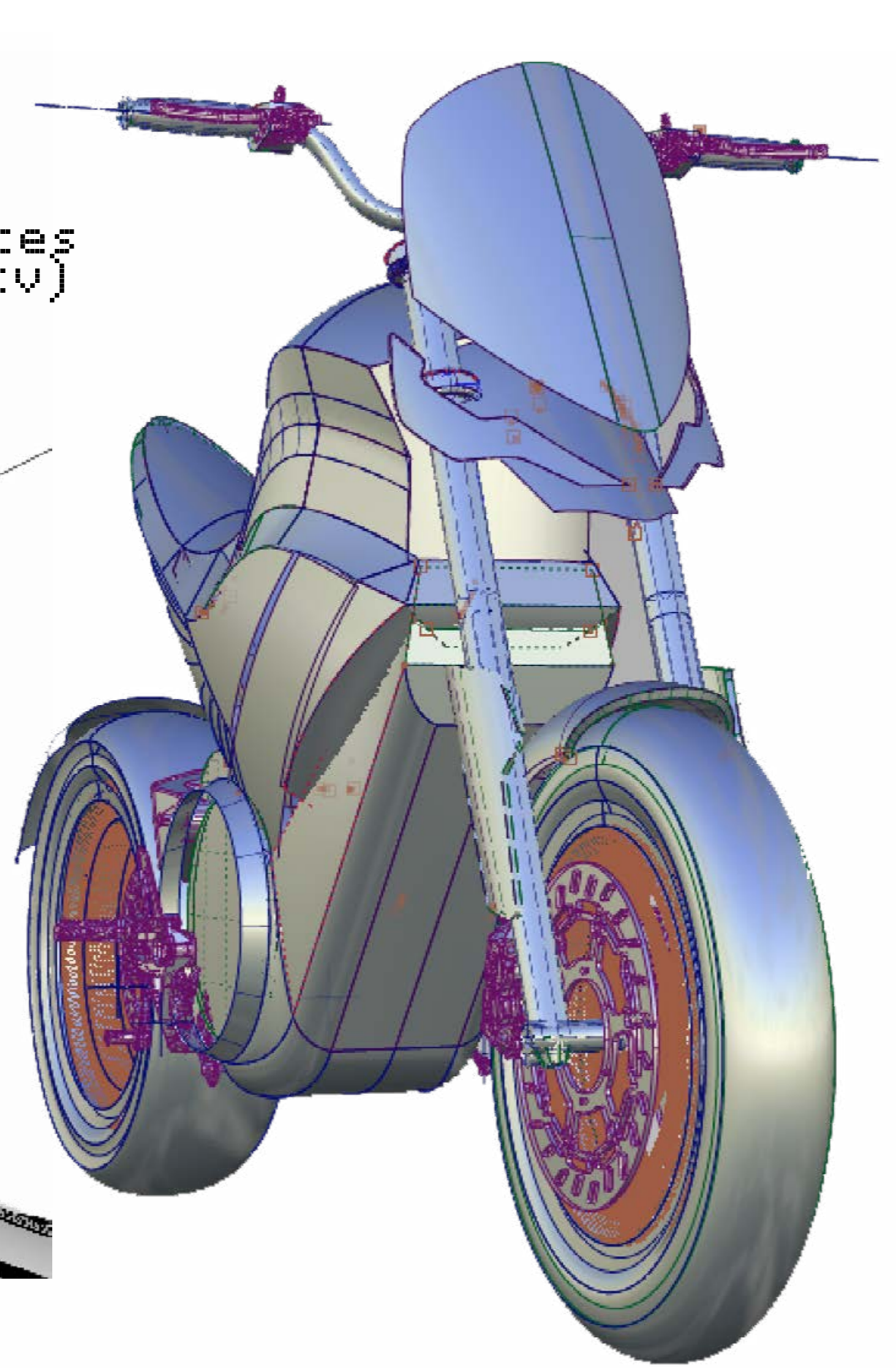

Even Distubution of
reflection .



//cluster design

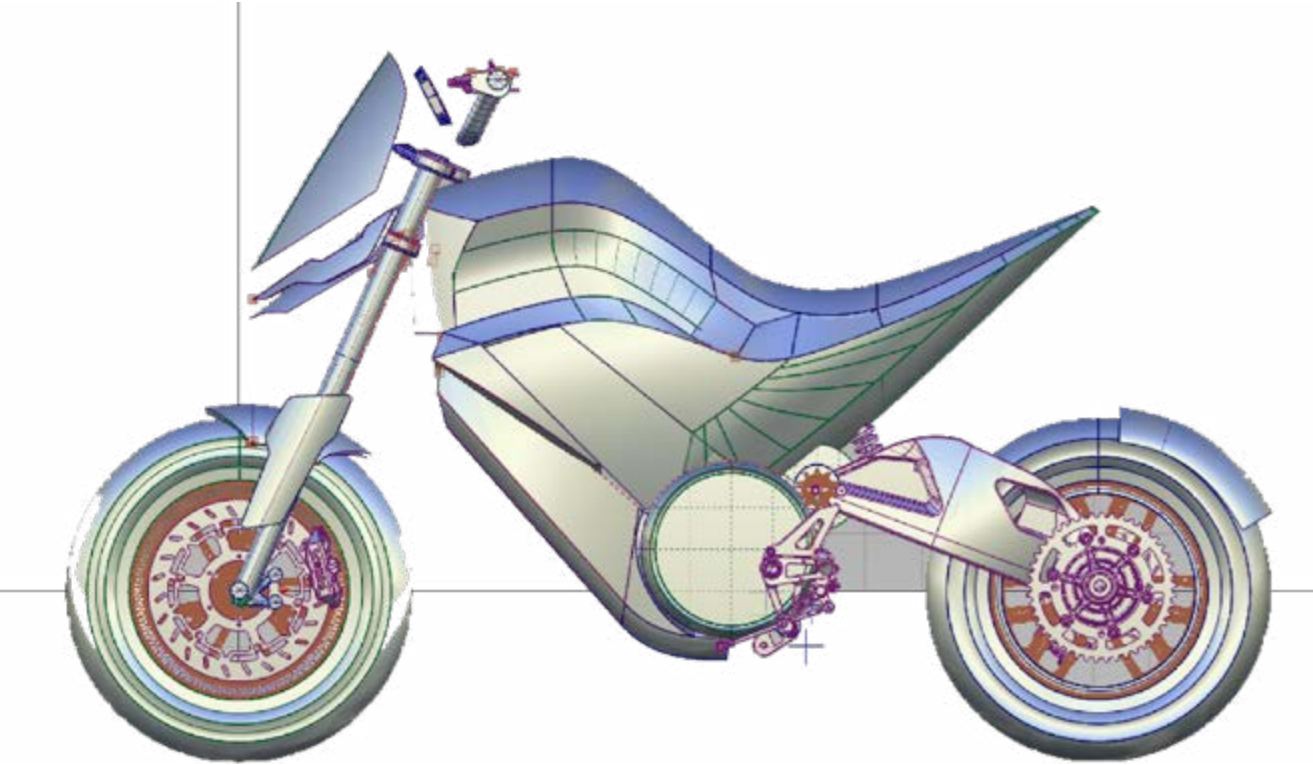

//alias exploration



//Photoshop exploration



emotional renders



Polestar Sonett-4

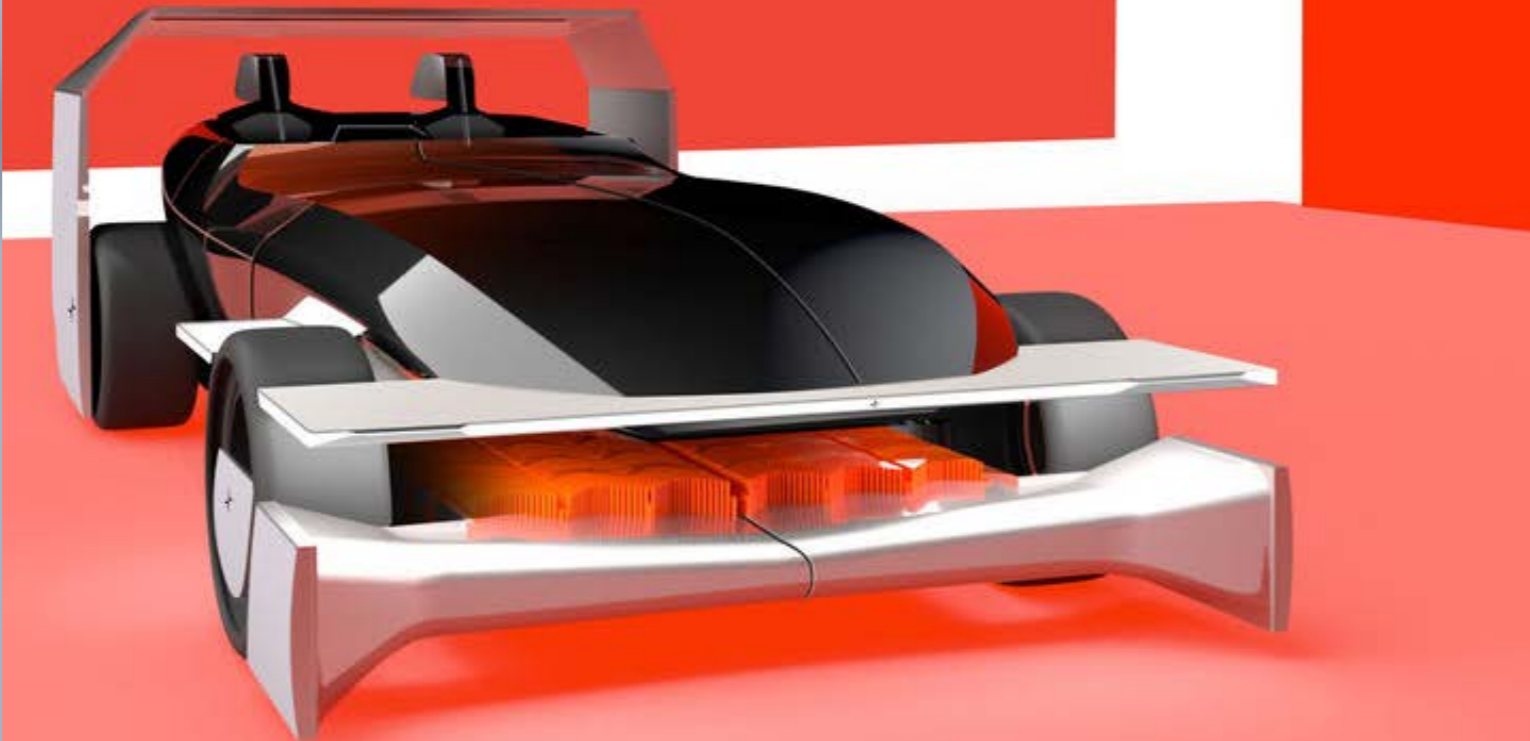
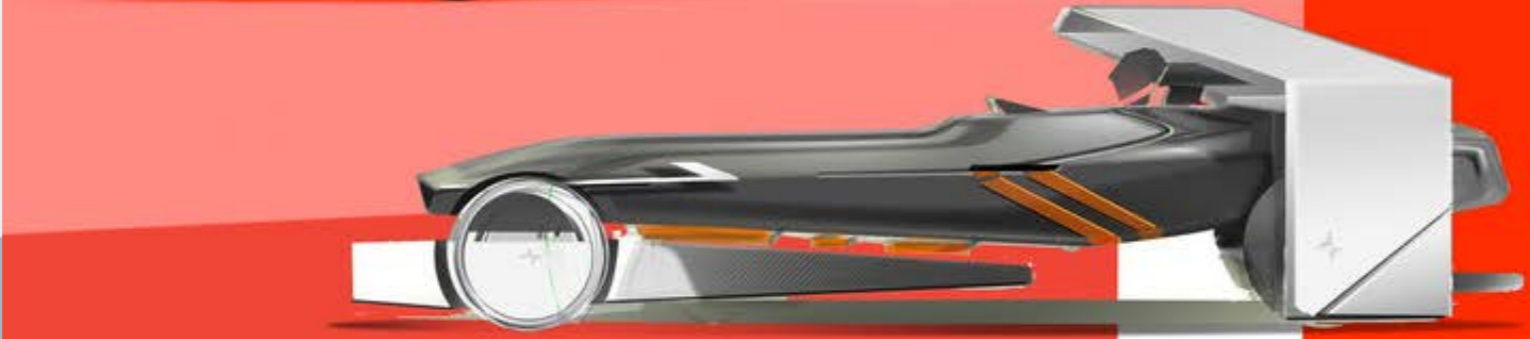
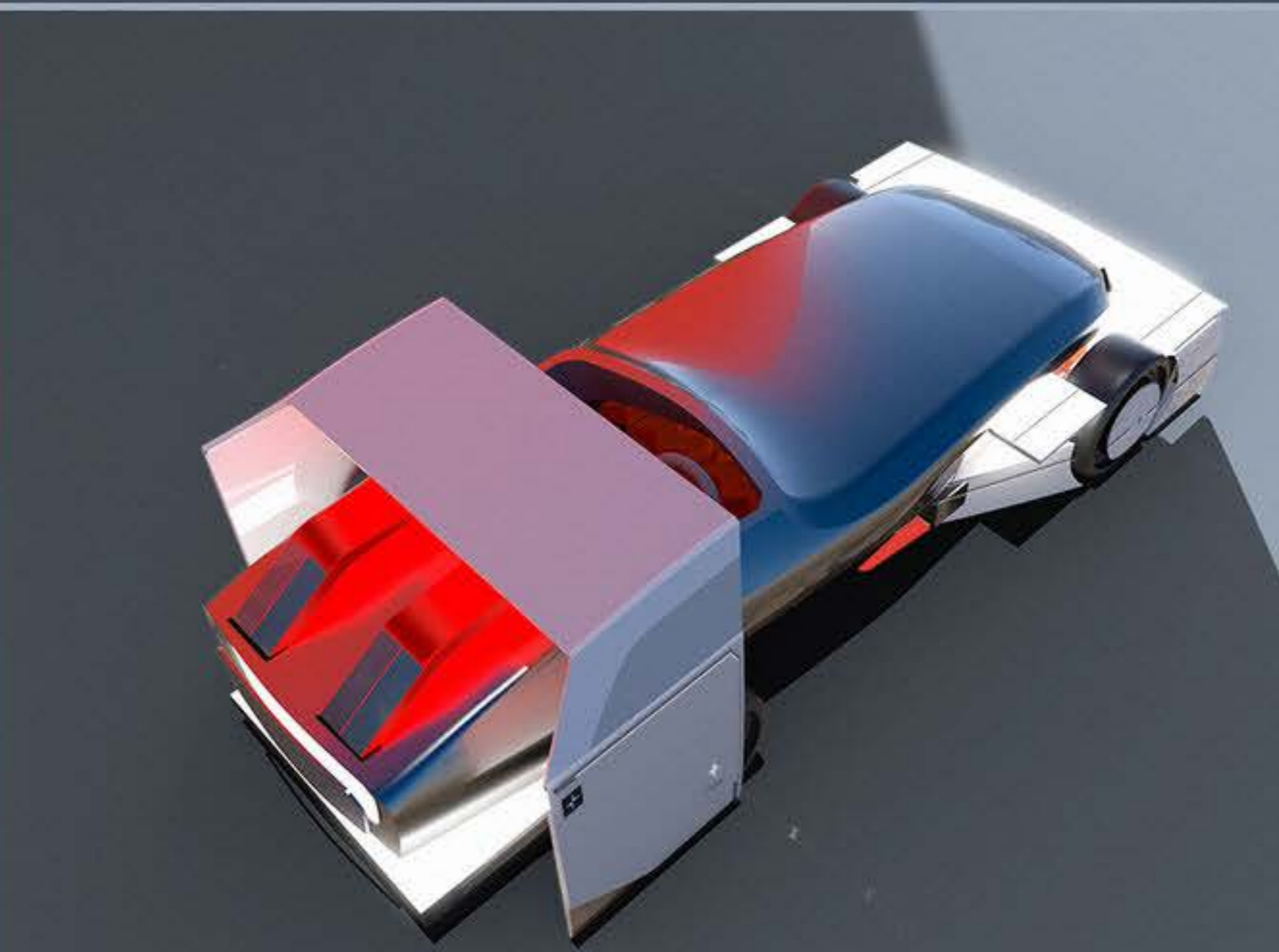
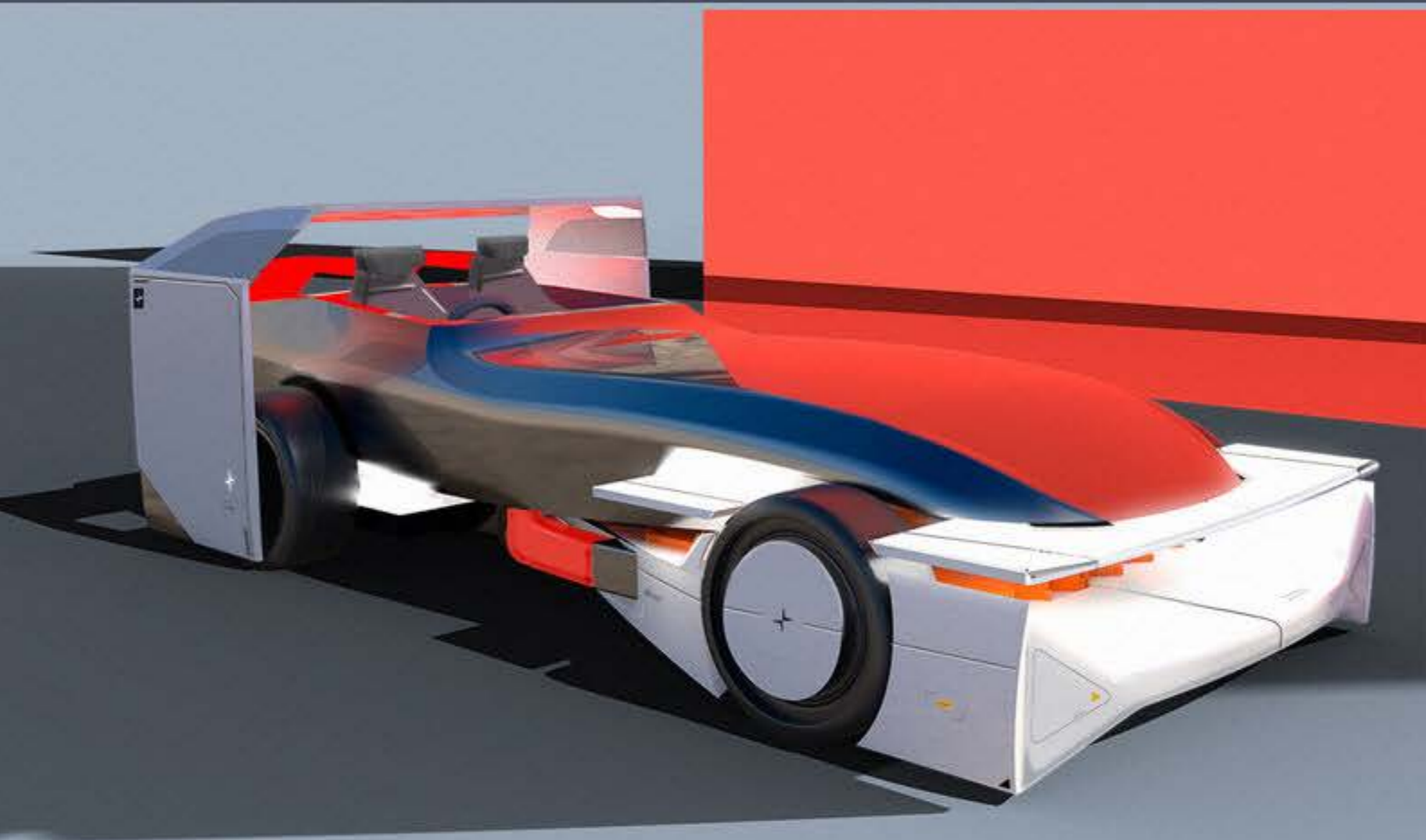

Square

A pure expression of a ridge shape is a clean square. Scandinavian design principle. A feeling of openness to light.



Contrast

White b/w Black represents square b/w curves. White towards the future and black to the past.

Connected Emphasized by Polestar accent colors



Engulfed by Light

play of Diffracted light and faces of a square. Invokes a sense of the car to the environment.

In White.

Ambient diffused light shoots in all directions.



Connect the capsule here

Elegance by sensuality

Curves inspired by p1800, encapsulating the driver. A Pure form balances its edgy counter-form.

In Black.

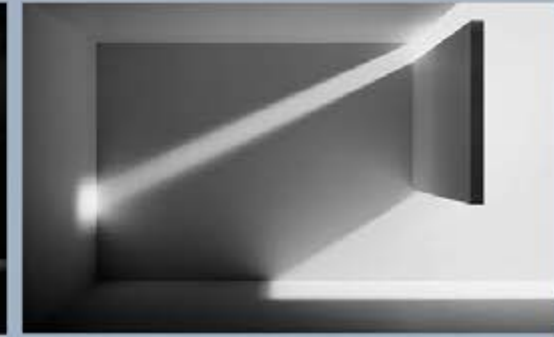

Polestar Sonett-4



Vintage

Curves on Volvo P1800 hints to the golden era for automobiles.

The year 2040 pays Homage to a fallen Scandinavian legend. The Saab Sonett 1.

The brand Polestar can revive fallen brothers. by adapting its architecture to a new philosophy

Homage





Lamborghini

\#Lamborghini
super sport sedan.

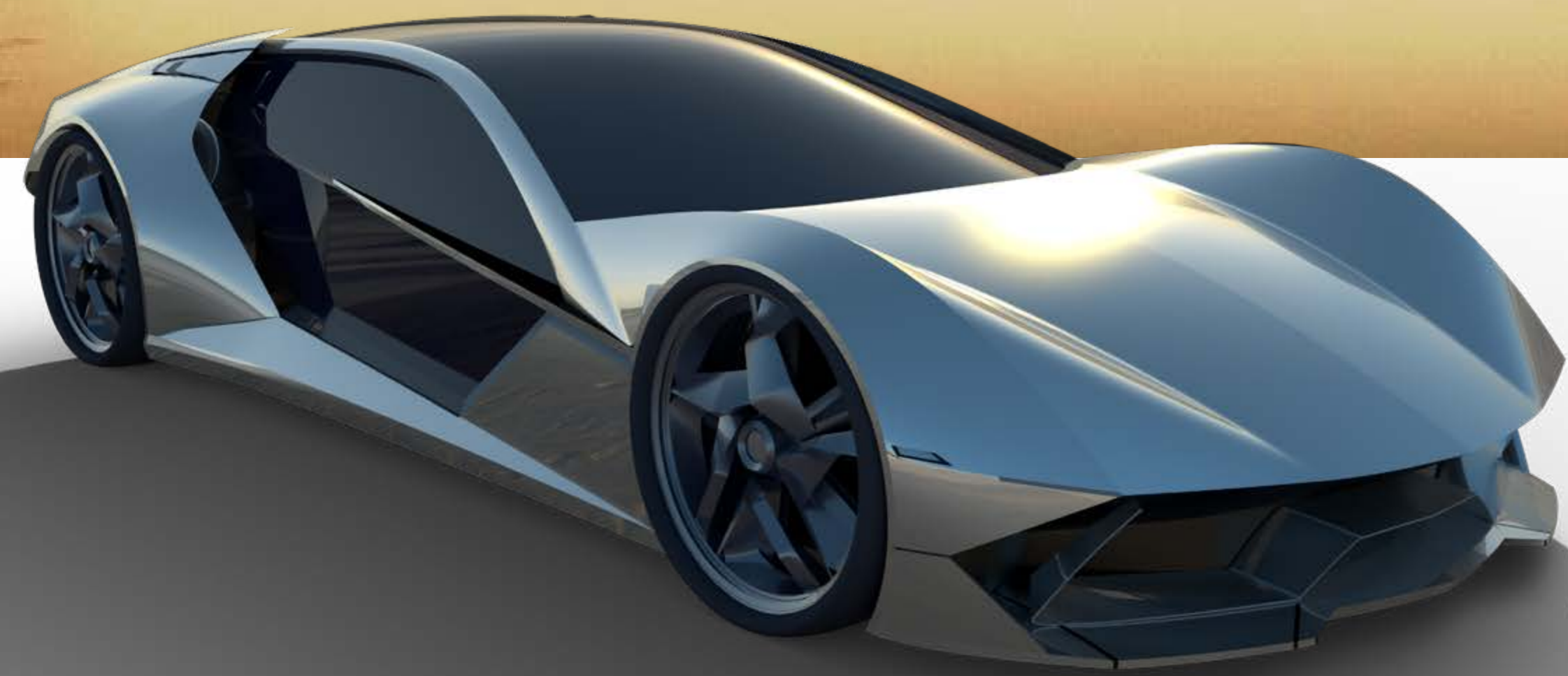

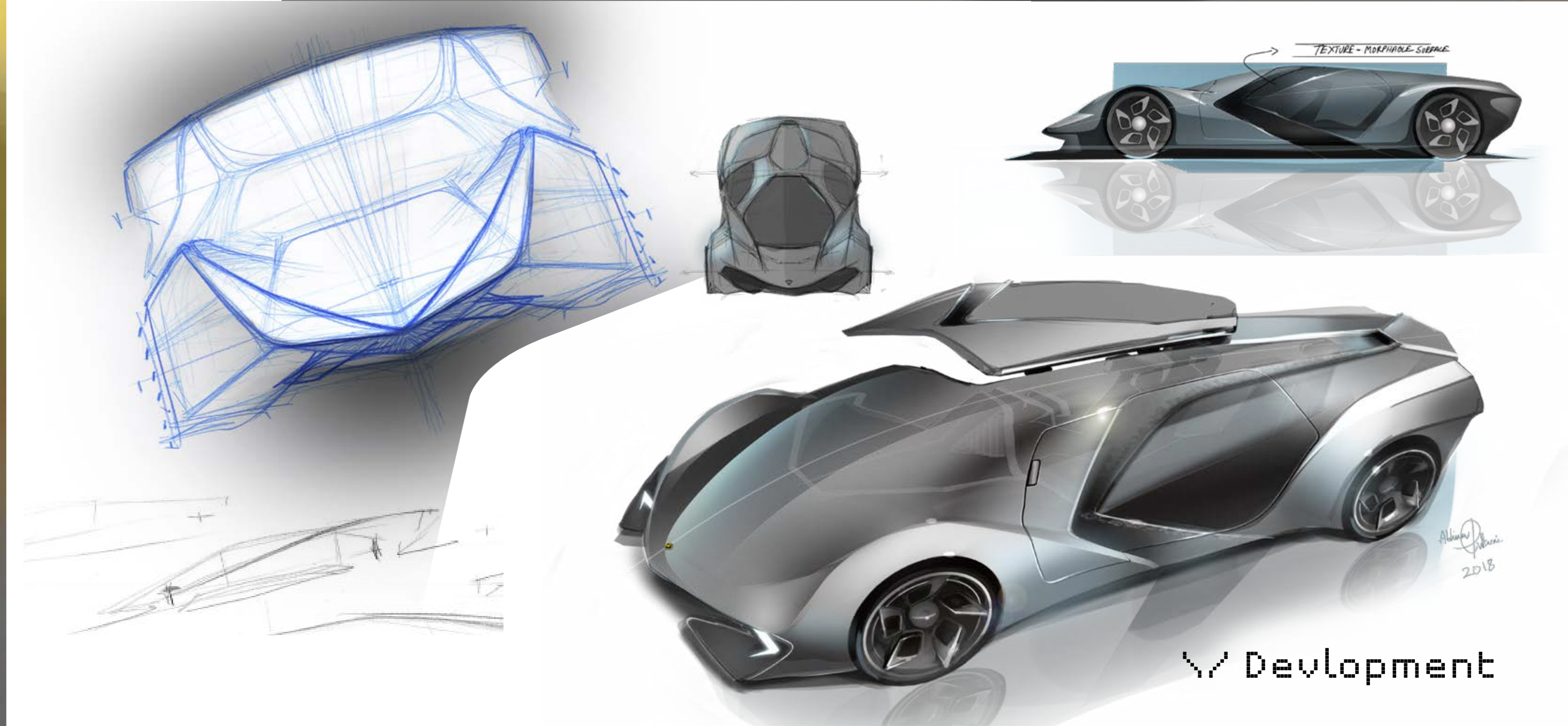
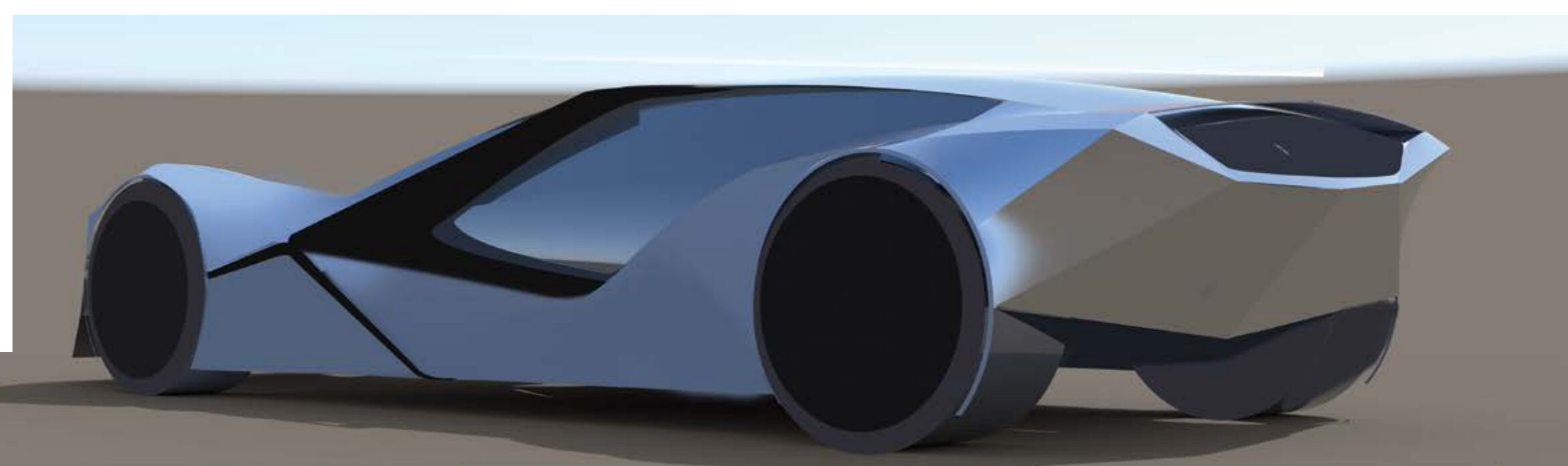
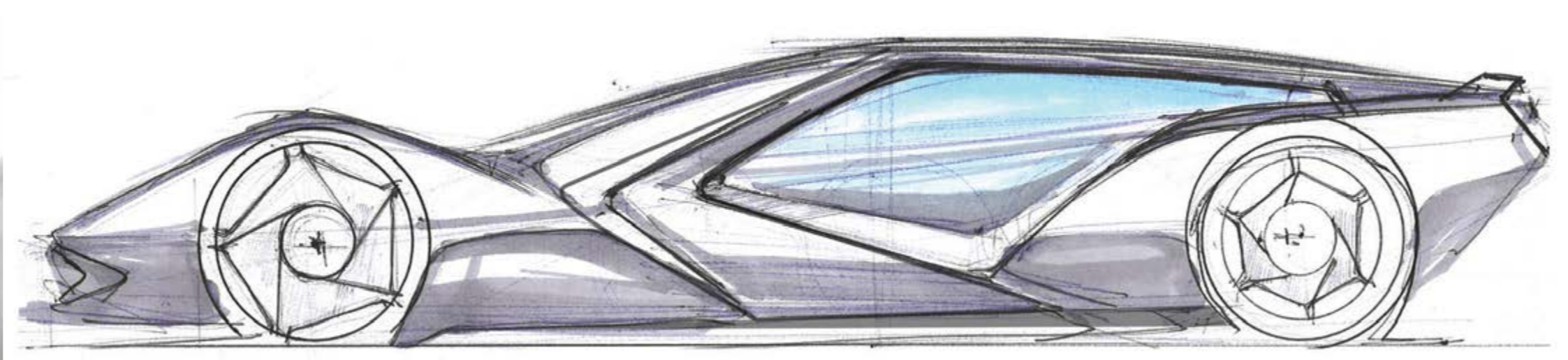
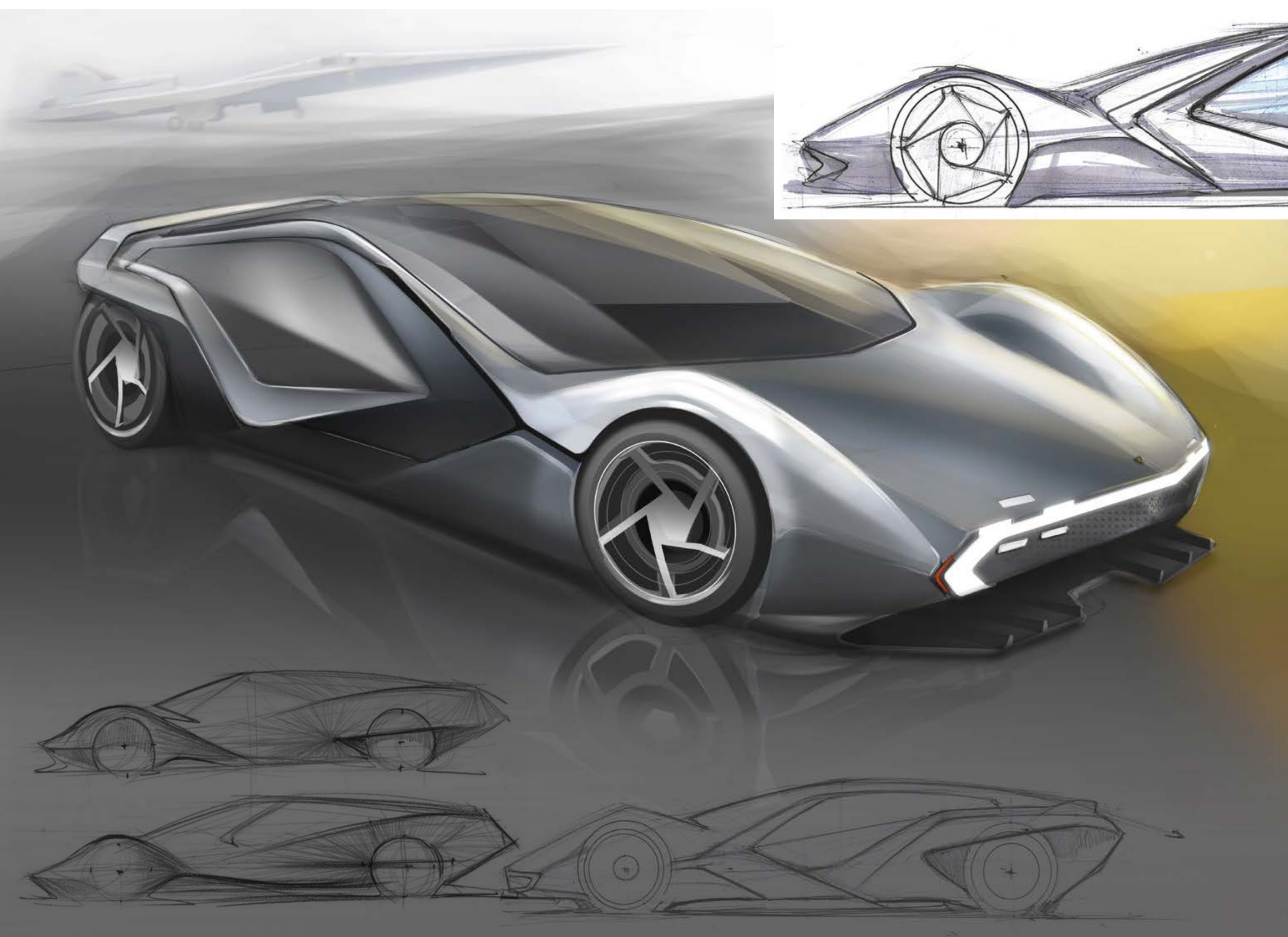

Development

\# 4 seater
&
2 door ingress

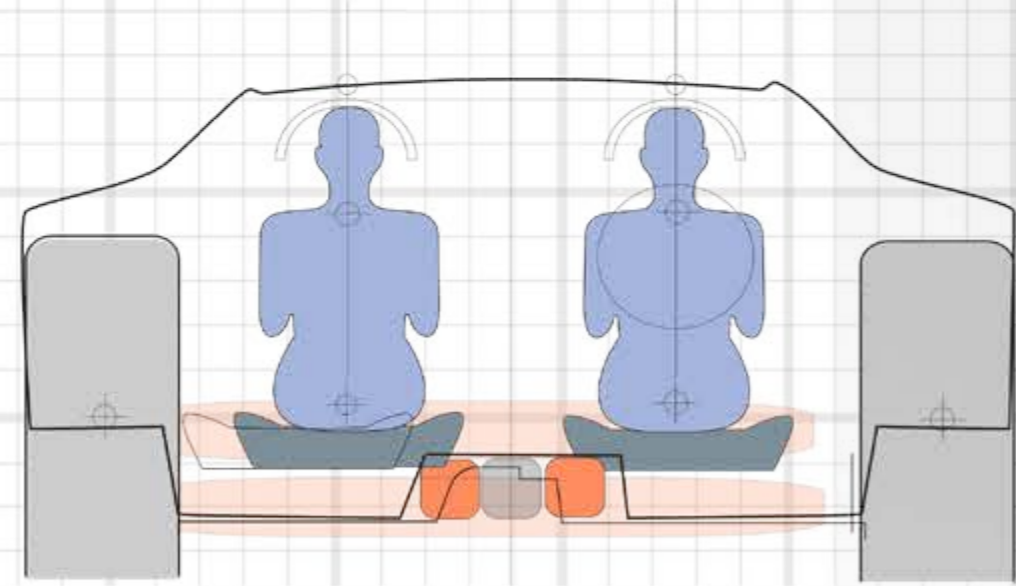

2200mm -Width

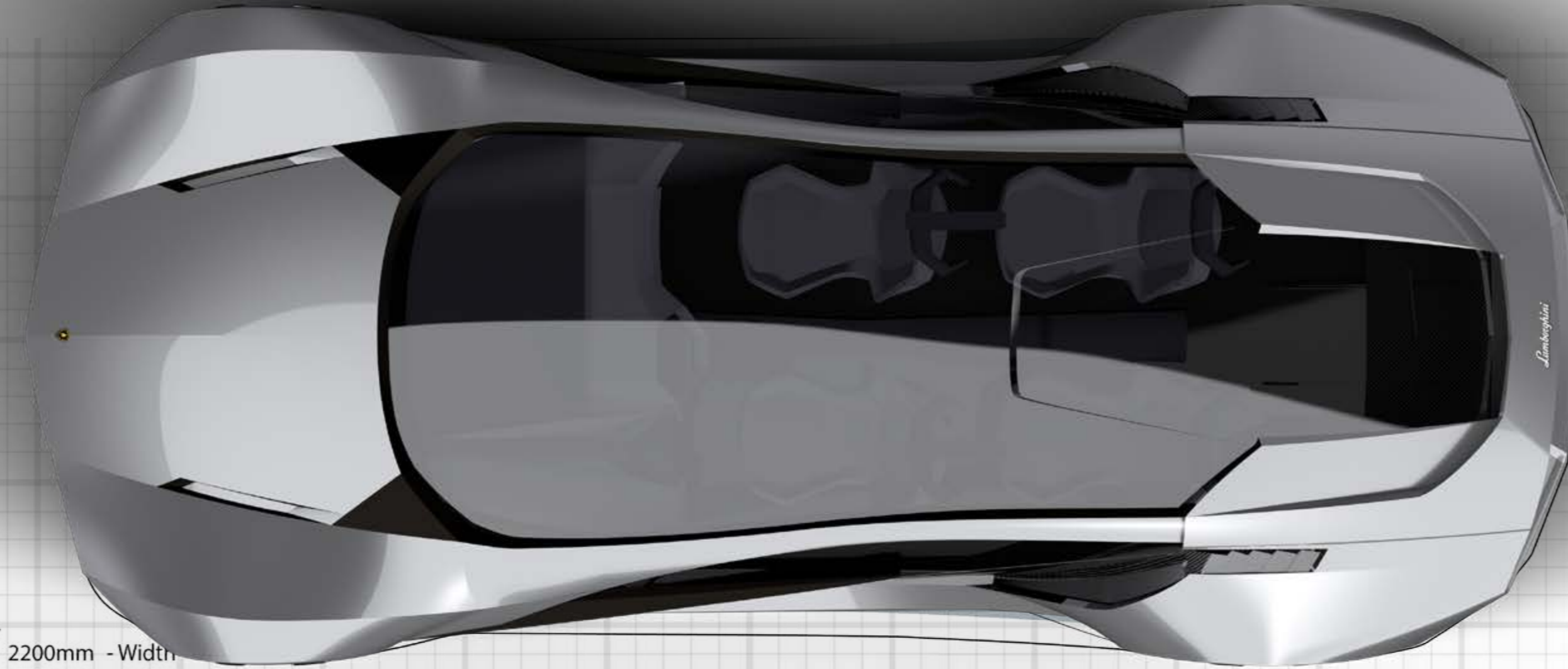

2200mm -Width

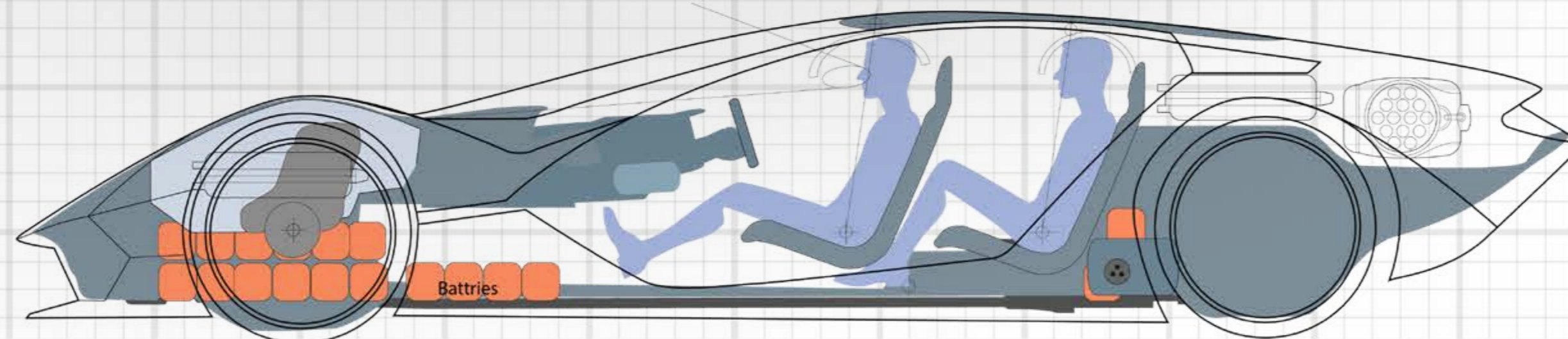

255/30ZR20 (92Y)

Batties

355/25ZR21 (107Y)

3400mm-Wheel base

5300mm-Length





Electric SUV

✓ Keysketch

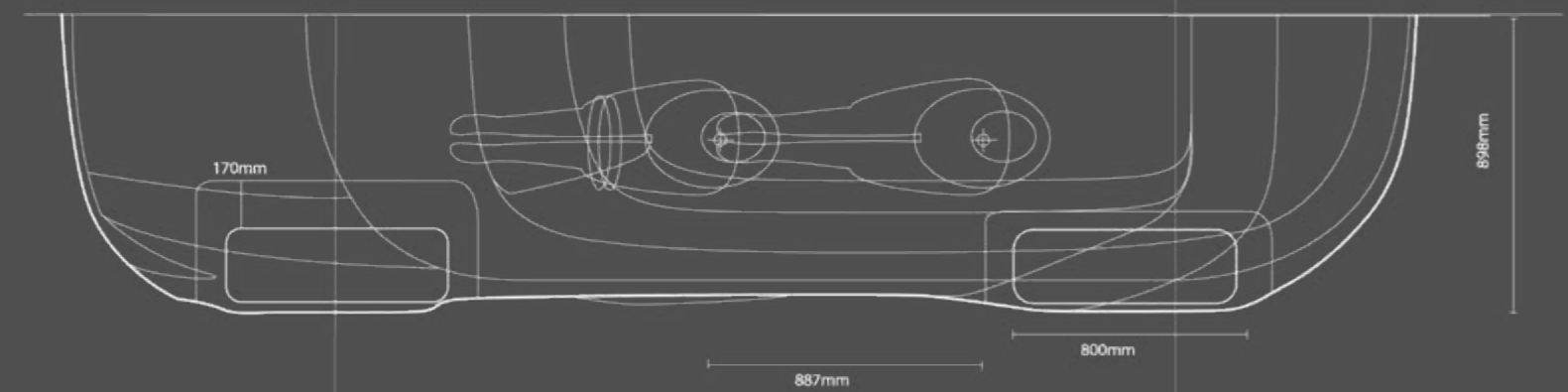
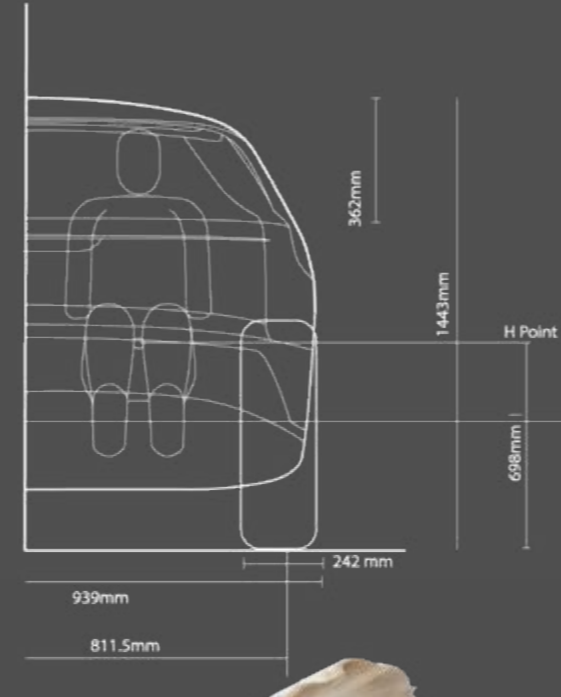
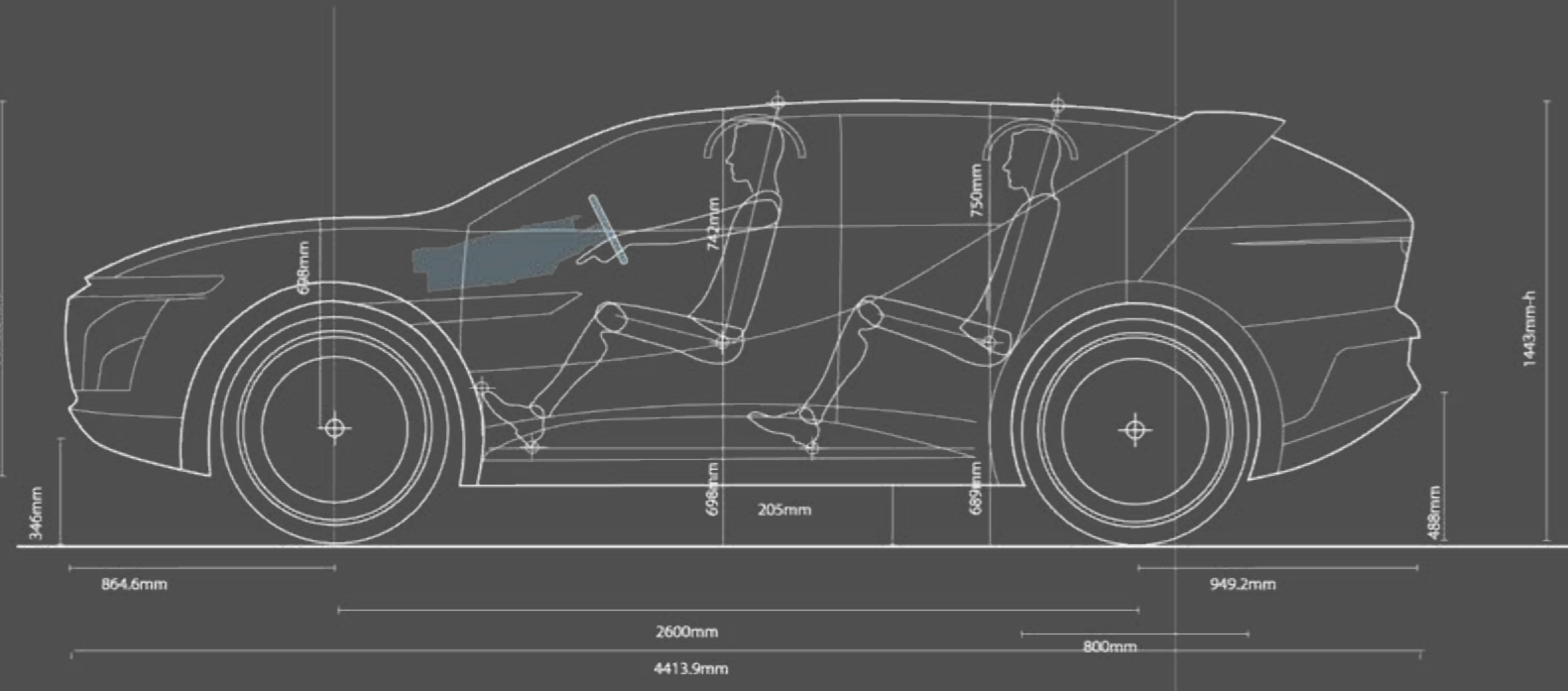
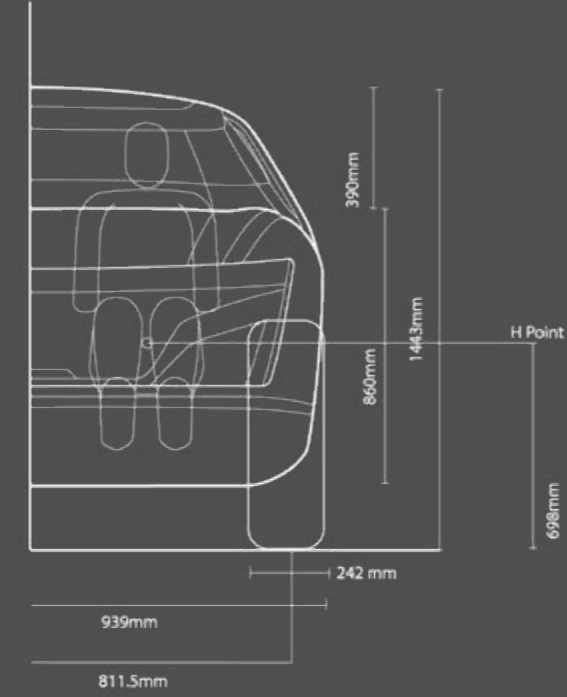
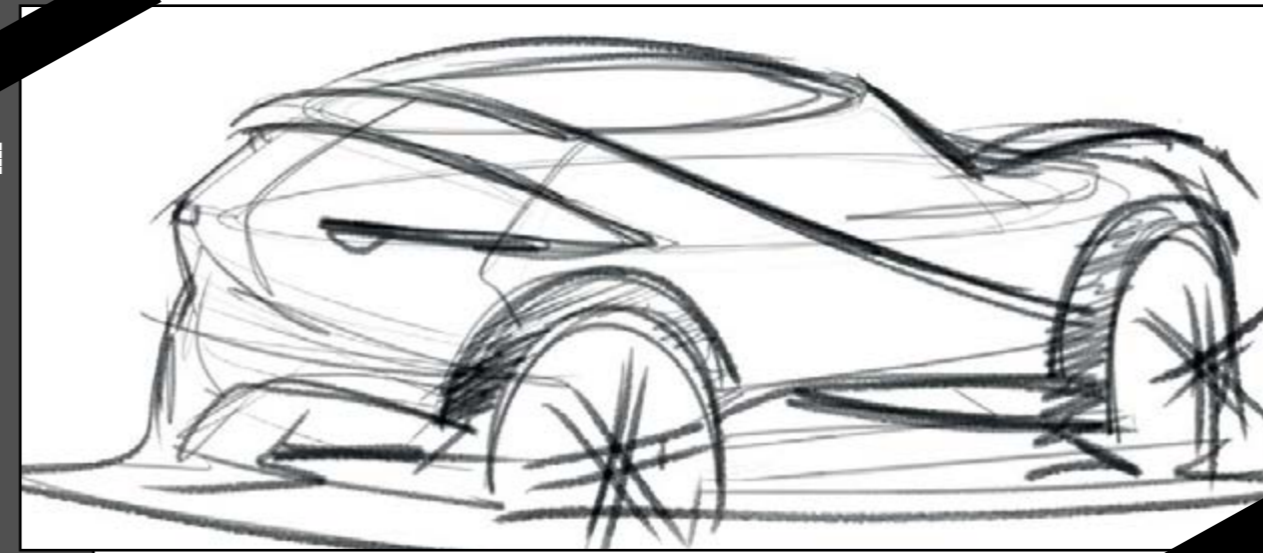

✓# Inspired by Oyster shell

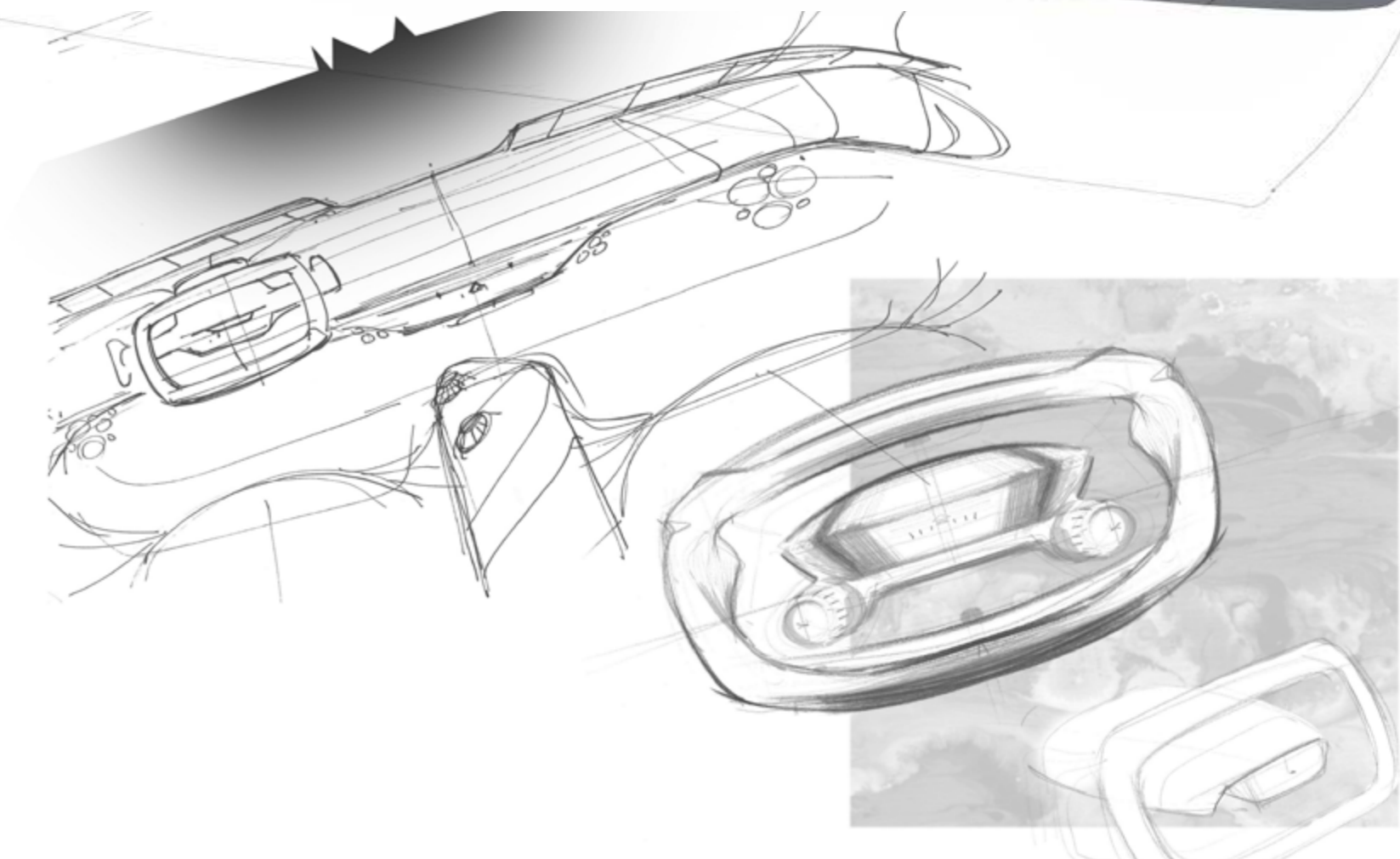
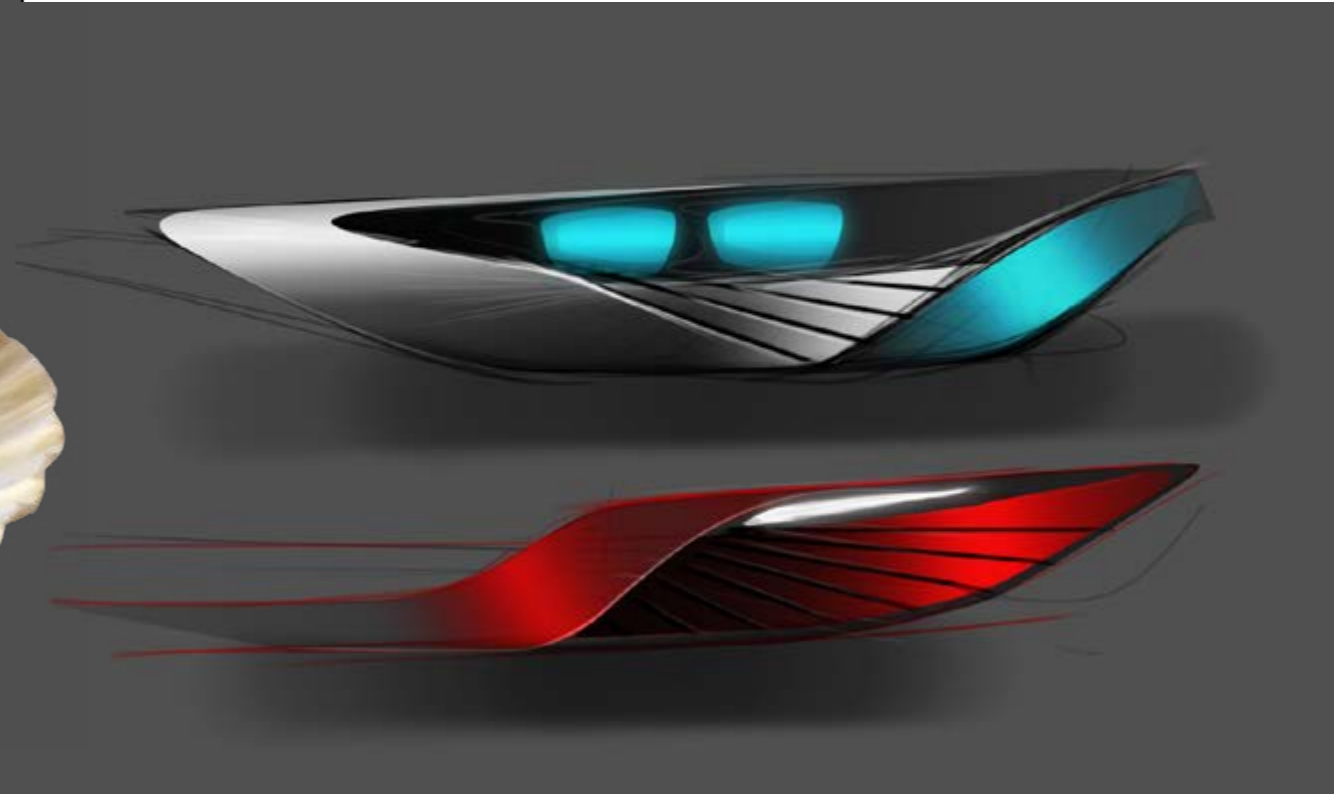
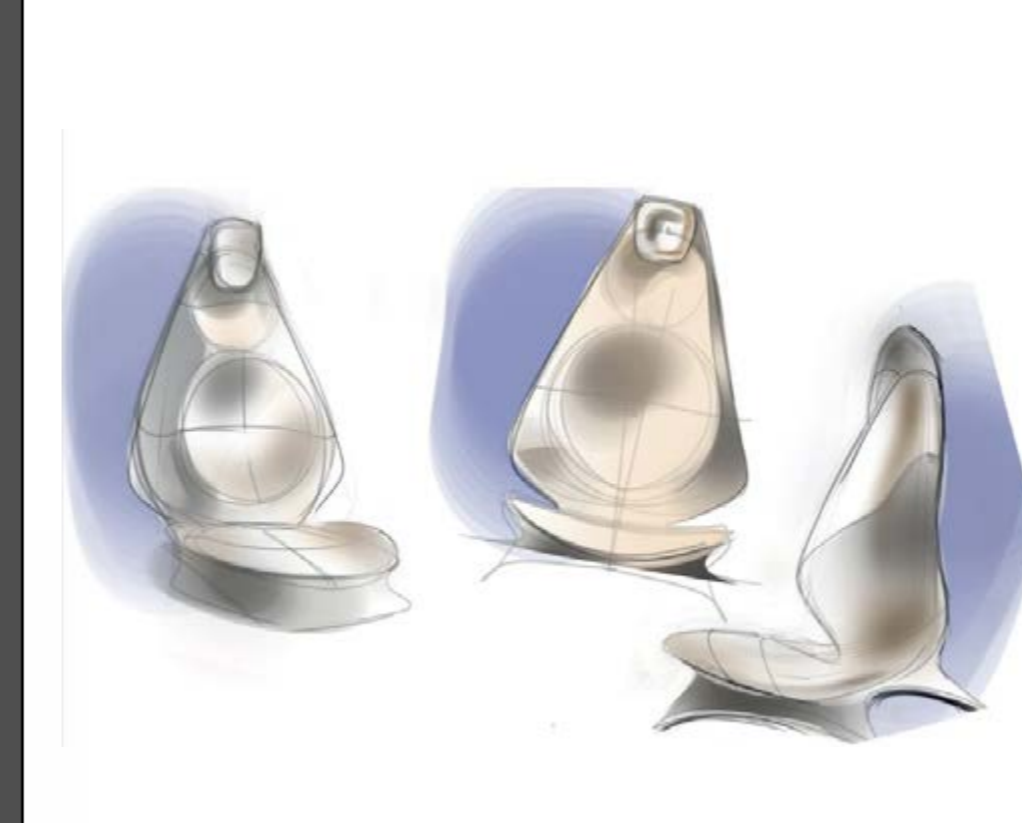







ITALDESIGN

QUATTRO





\# using existing infrastructure
can we make a **quadricycle**,
that sits **low** and still retains desirability
amongst a **new generation**.

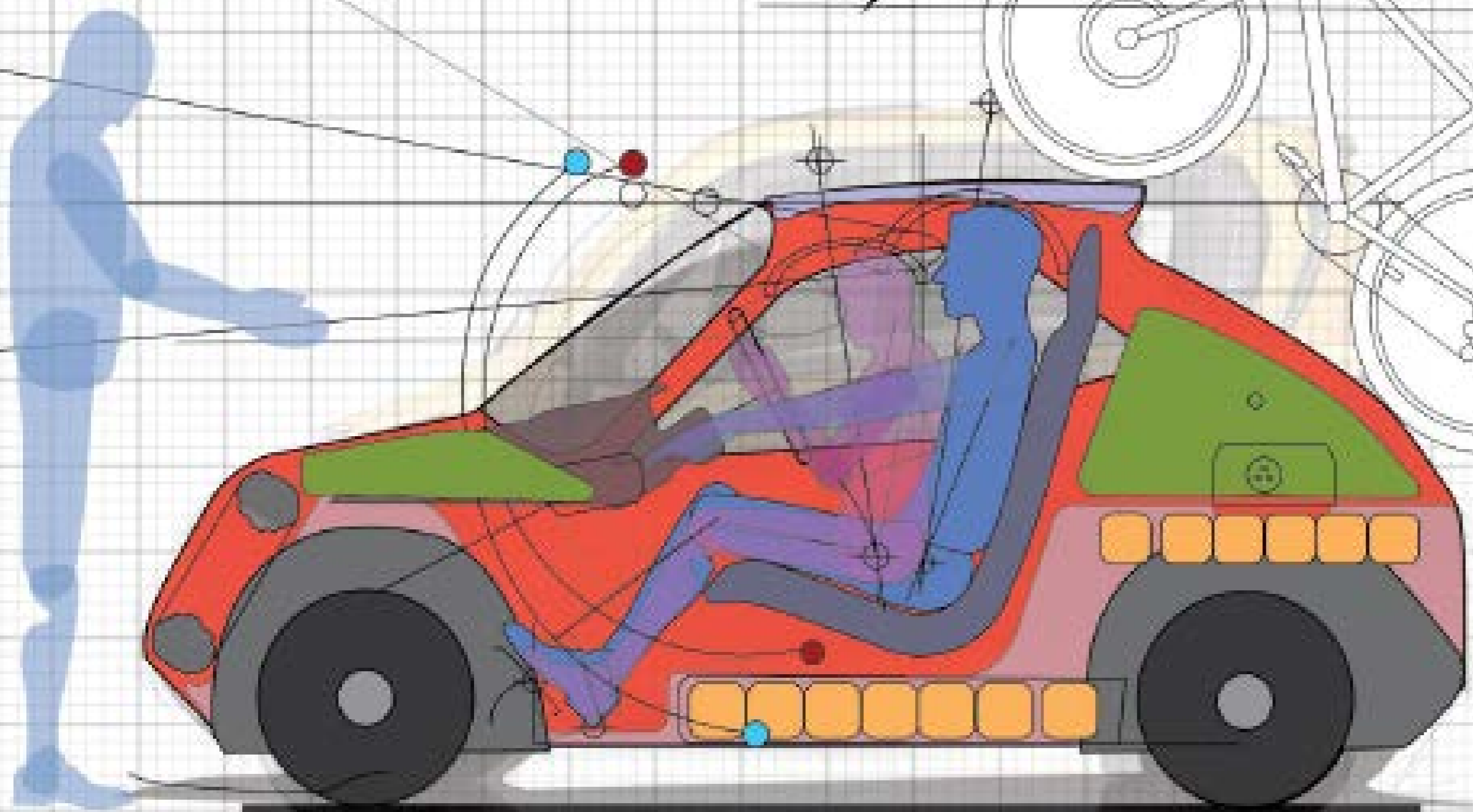
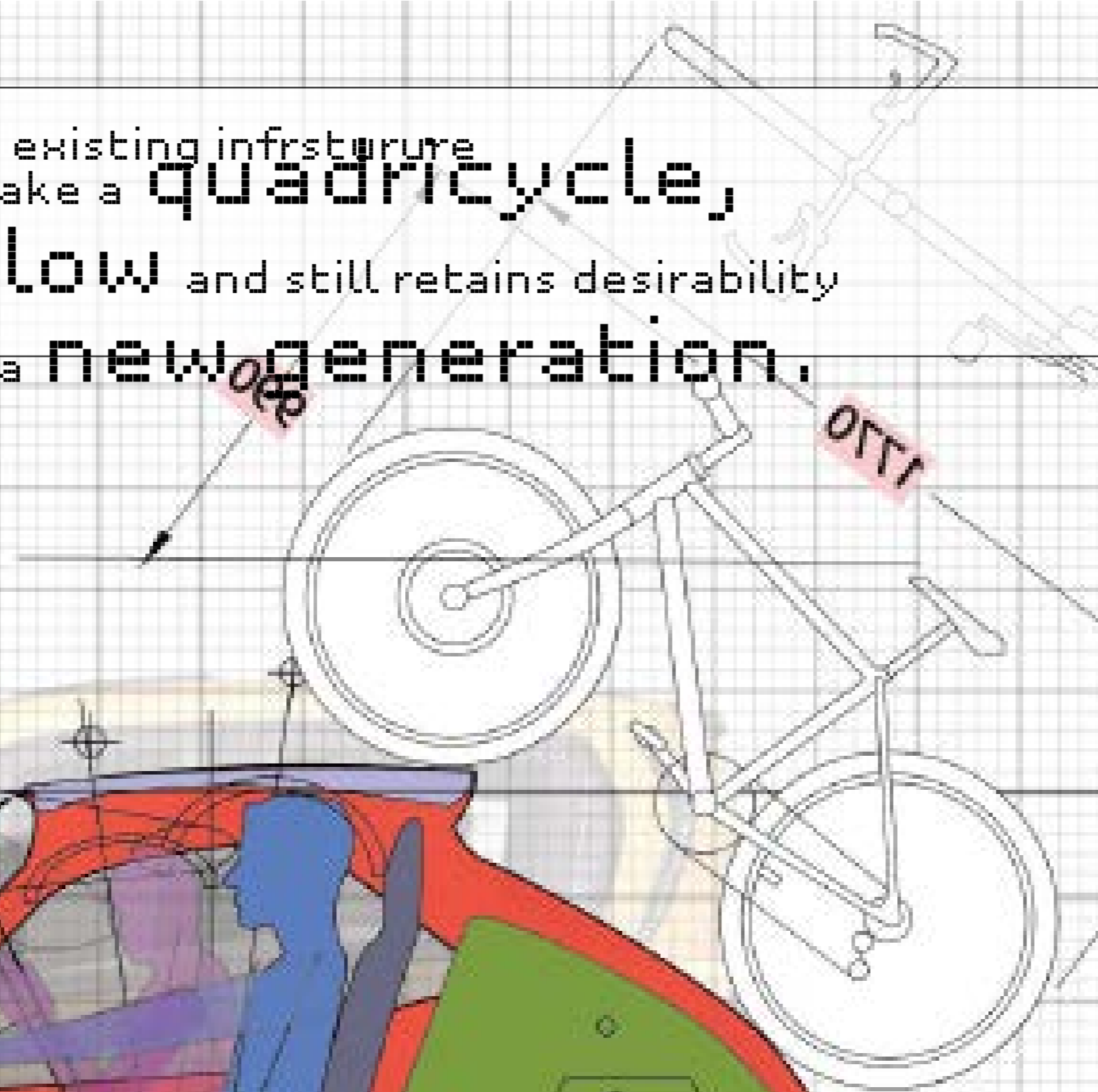

\#city car

Micro quadcycle

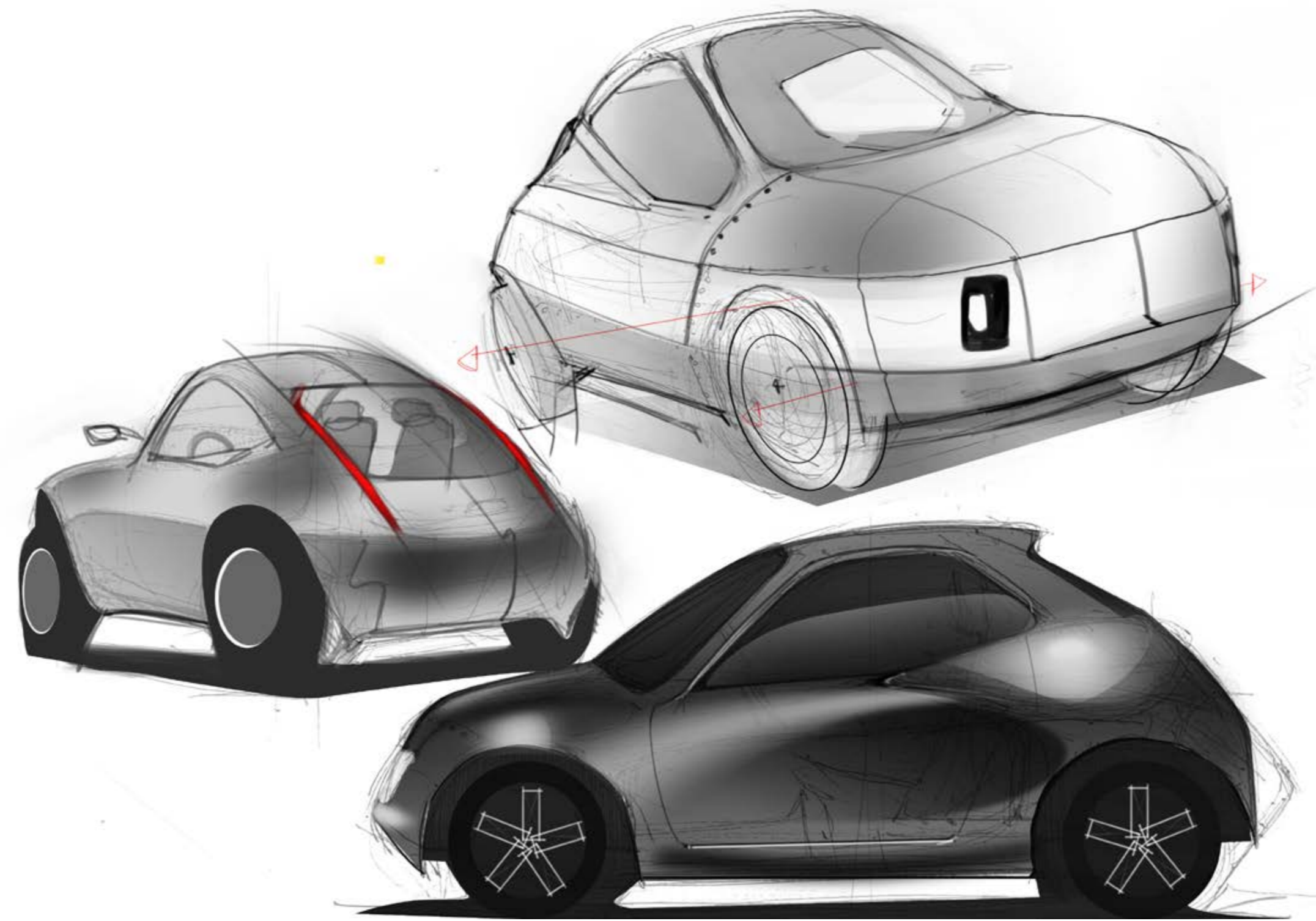

SUSTAINABLE SYSTEM DESIGN

DESIGNED TO MANUFACTURE

MINIMAL BUT EXPRESSIVE DESIGN LANGUAGE

RECYCLE / PURPOSEFUL AFTERLIFE

LOW COST AUTOMATION

SHARED OWNERSHIP

USAGE/ DISCARD AT WILL

PROFITABLE BUSINESS MODULE

USER :

SOLUTION AGAINST THEFT / MISUSE

EASY USAGE AND ERGONOMIC

COMMUNITY

ENHANCE OR EASE BICYCLE / LAST MILE

PARKING

SOLUTION AGAINST CONGESTION

LOW -DEPENDENCE FROM GRID FOR ELECTRICITY

\#skills

Miscellaneous

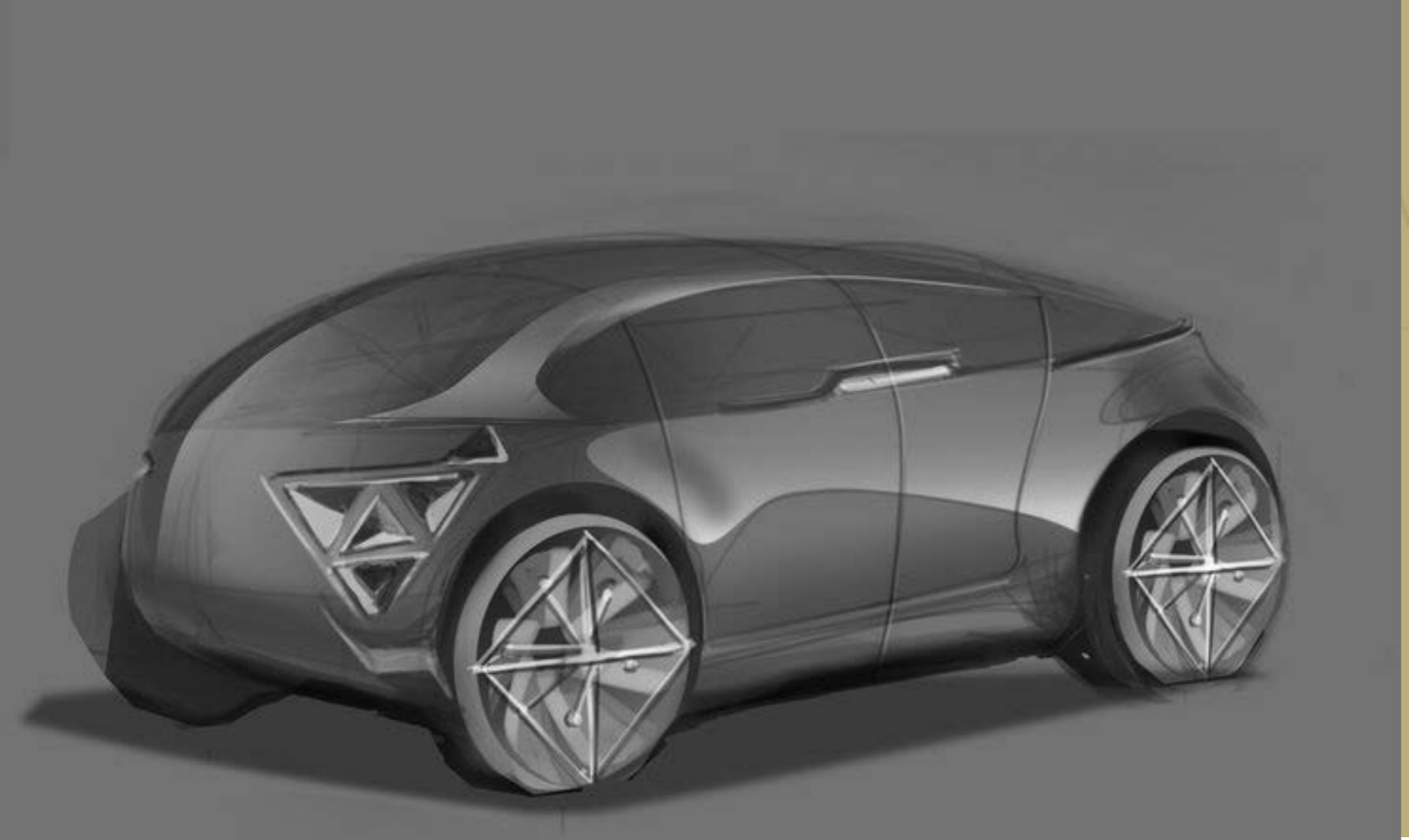

END//