



abhinav's
car design

PORTFOLIO
for
2020



This is a showcase of my abilities as creative in the field of Transportation design.

Through my journey, I realized an authentic voice to support my creative expression is paramount for once personality.

I am not a perfectionist, nor i will ever try to be one. Rather work in a bluesky or a poetic approach. that helps a design team to create a value.

*I am not desperate to convince
A design community Hire me,*

I just want makes vehicles that contribute to progress of humanity. ... :D



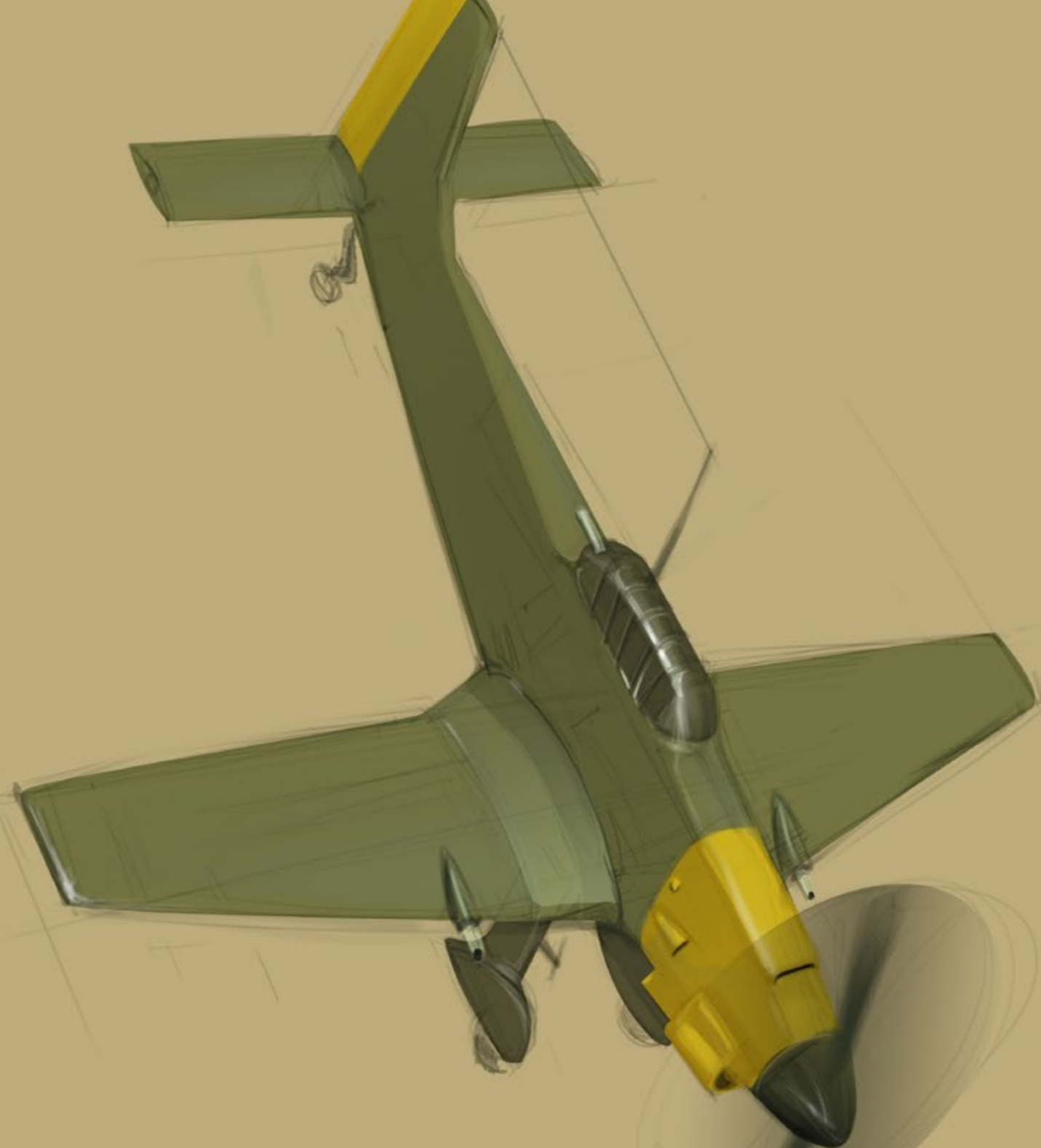

CONTENTS :



1) LAMBORGHINI CLASSROOM PROJECT

*-A group project, Lamborghini Marzal
for year 2040*



2) DUCATI CLASSROOM PROJECT

*- A group project for new electric motorcycle-
New Architecture for Ducati*



3) ITALDESIGN CLASSROOM PROJECT

*A group project for a -
Quintessential Italian SUV*



BRIEF: SUPERSPORT SEDAN FOR 2040.



A LAMBORGHINI MARZAL HOMAGE.



PACKAGE :

4 PASSENGER

- COCOONED
- INSPIRED FROM SPACE SHUTTLE CABIN
- MORPHABLE BIO-COMPOSIT FOAM FOR HIGH SPEED ERGONOMICS



*KEY WORDS.

SOFT AGGRESSION
TACTILE
TRANSPARENT

*KEY FEELING

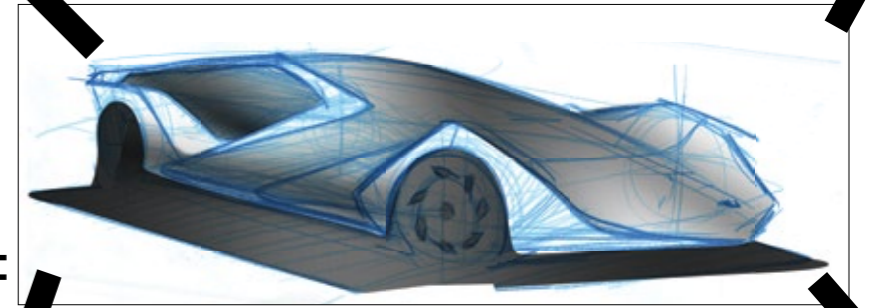

radio com: ...what is your current speed alpha lambo?
Yazaku: ...we are doing a 544kmph
radio com: ...can you make it quick? we have cleared the tube...you are green 600+
yazaku:roger!ETA 40sec to launch site

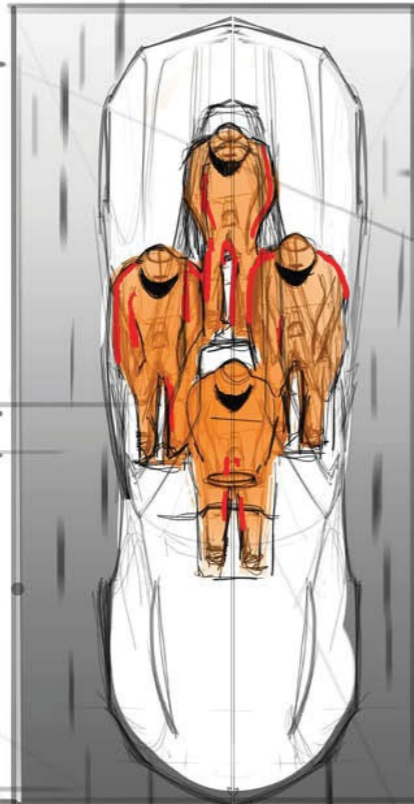
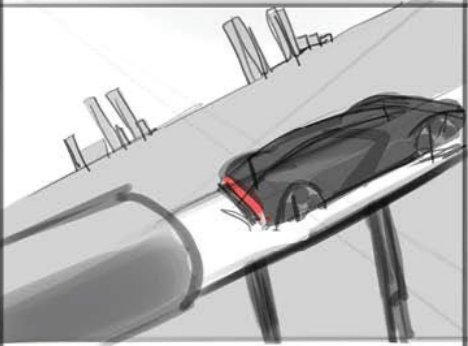

jim: Phew we reached the launch pad !! That was Quick, but we just left the station, I am in need of some sleep man!

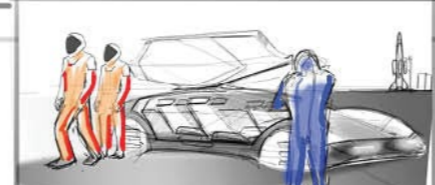

yazaku : Bro! You can have all the sleep you want in the ship, the seats are the same as the "lambo-shuttle car".

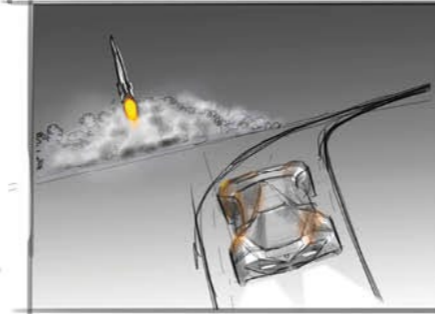

DEFINITION OF SPEED IS AT CHANGE.
HOMAGE TO SUPERSONIC SPEEDS.

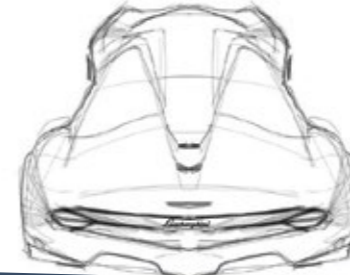
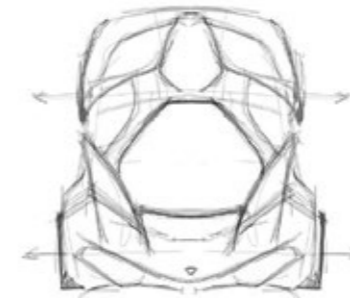

SUPERSPORT SEDAN ARCHITECTURE

*KEY SKETCH

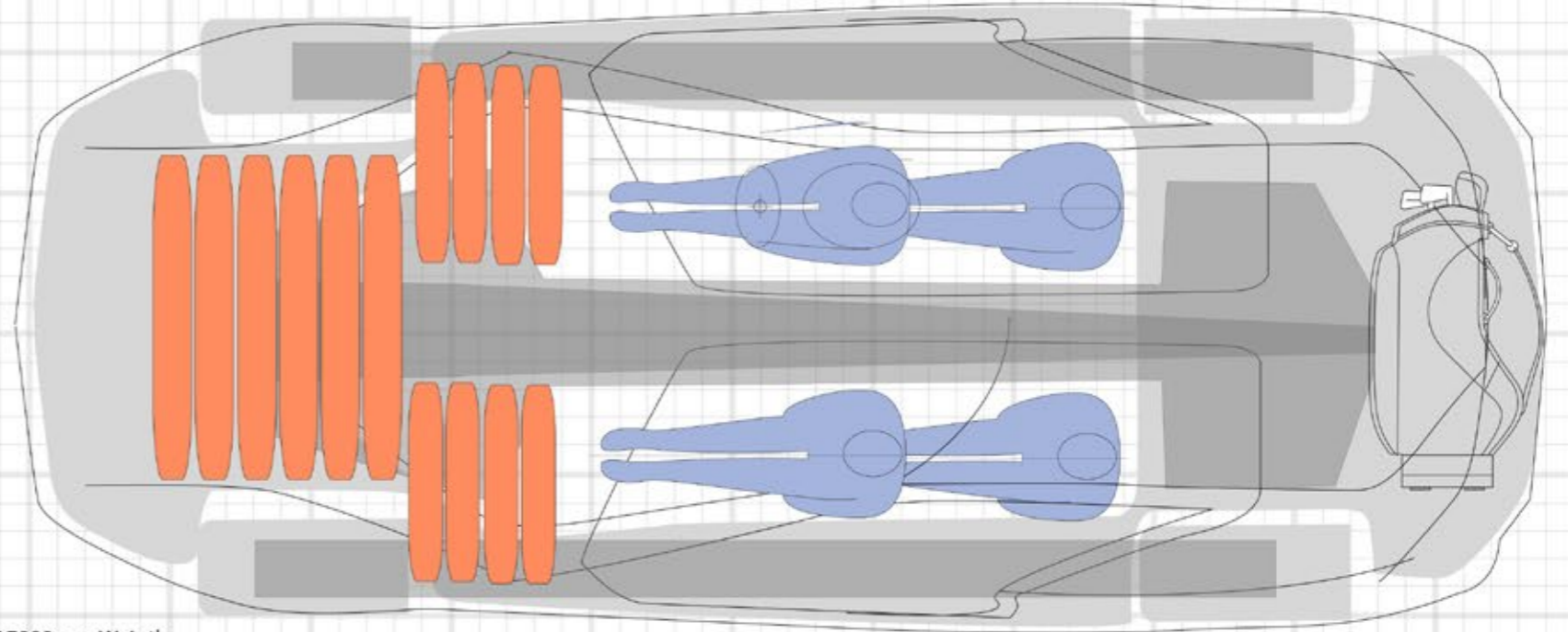
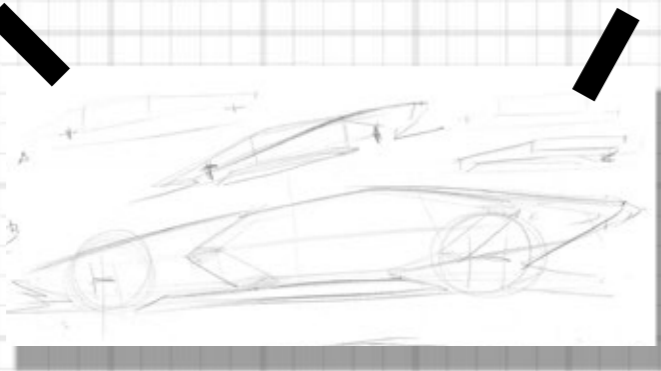

17900mm-Weigth

PACKAGE

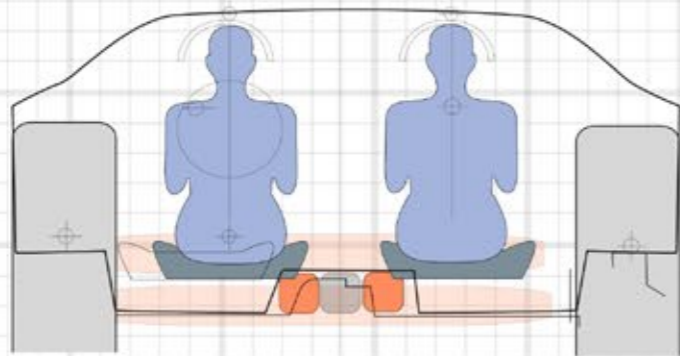

17900mm-Weigth



1100mm-Height

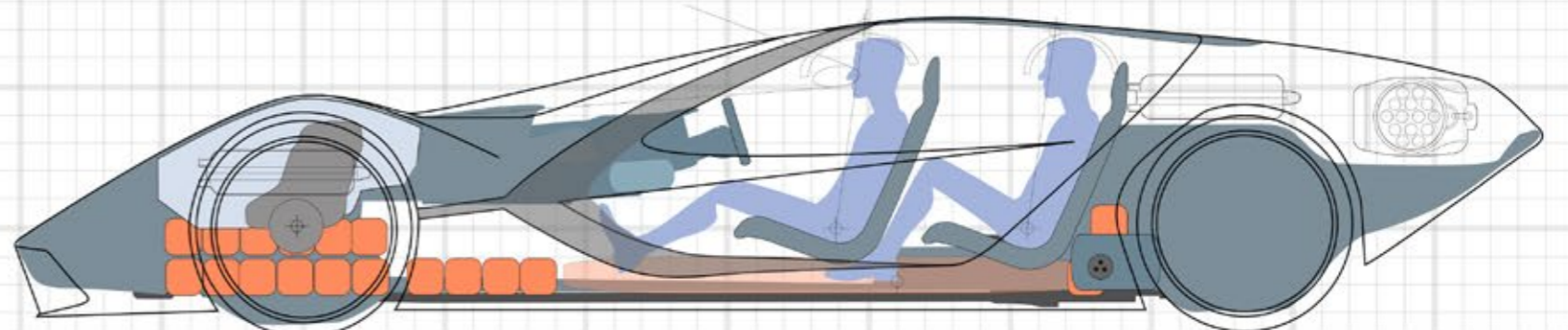

3400mm-Wheel base

4990mm-Length



**INITIAL CONCEPT
SKETCH RENDER**

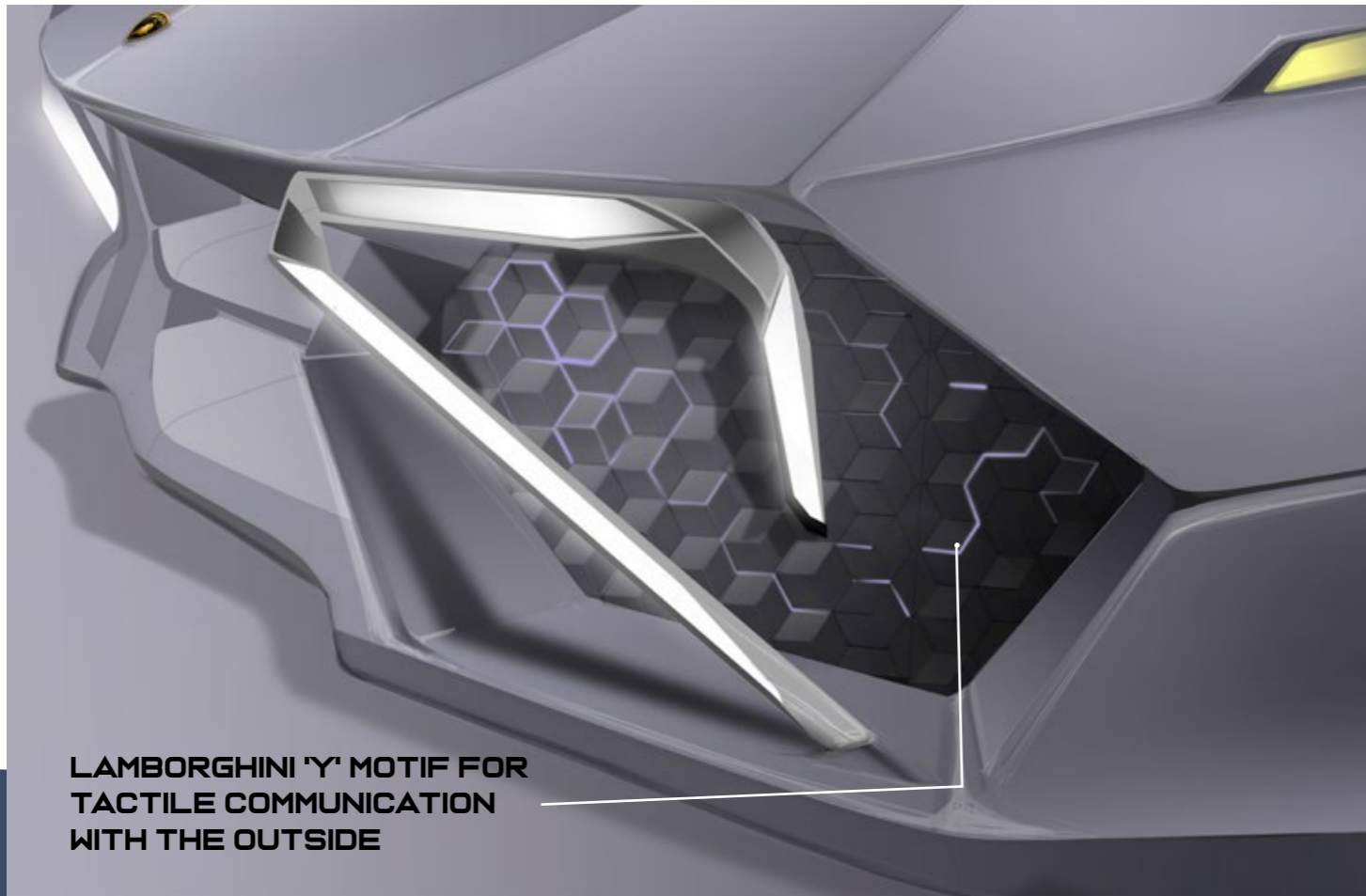

**LAMBORGHINI 'Y' MOTIF FOR
TACTILE COMMUNICATION
WITH THE OUTSIDE**

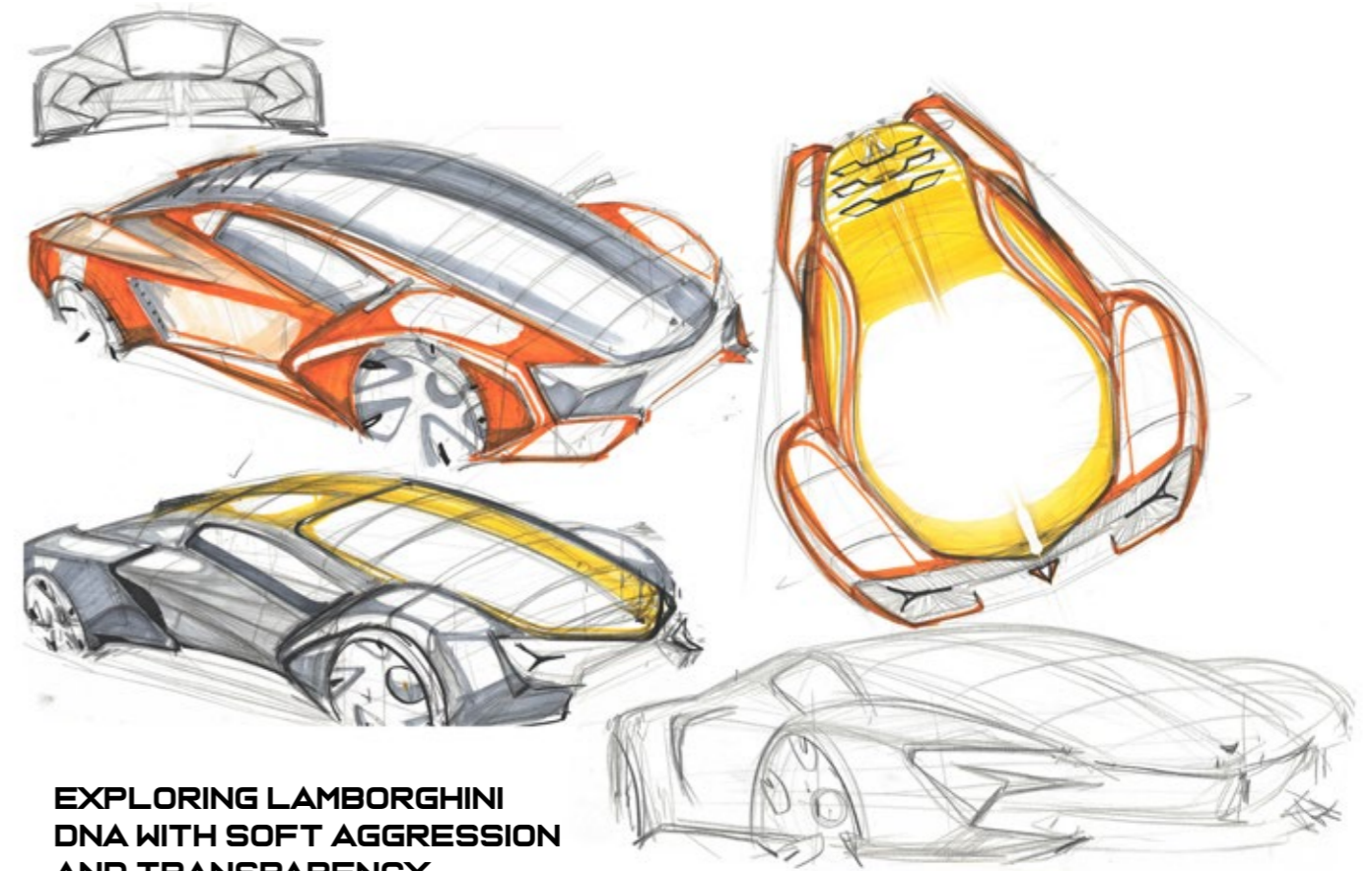

**EXPLORING LAMBORGHINI
DNA WITH SOFT AGGRESSION
AND TRANSPARENCY**

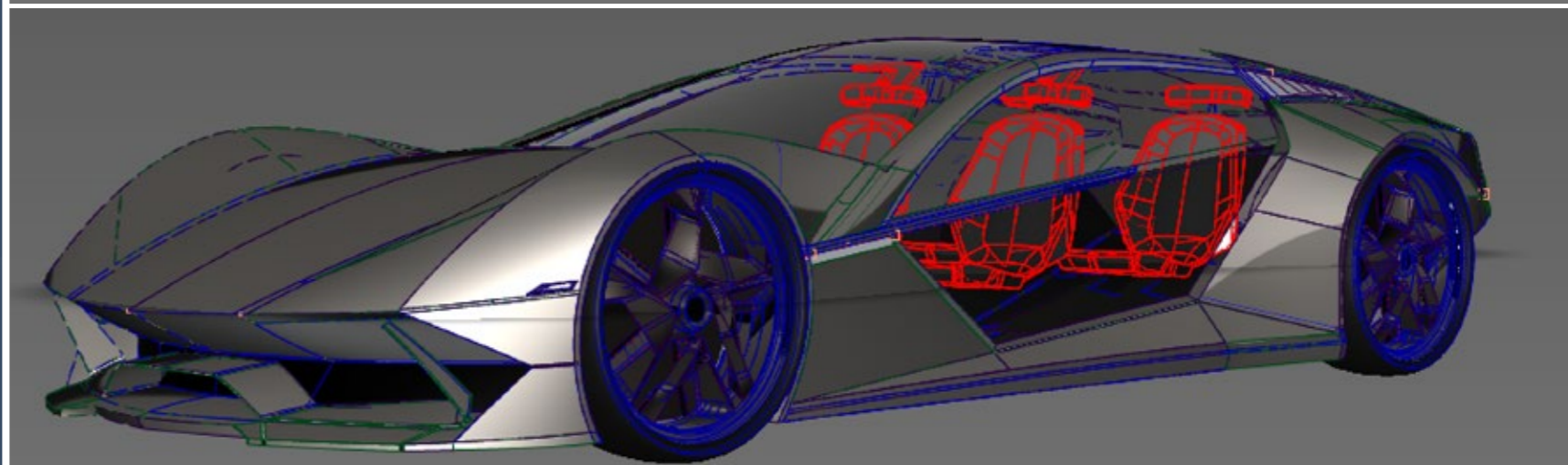
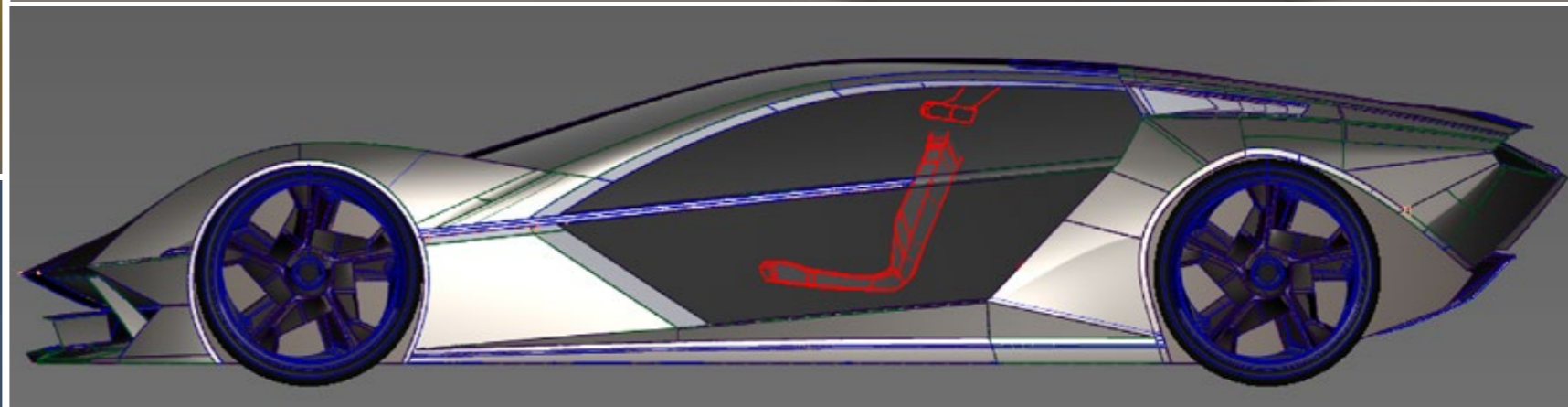
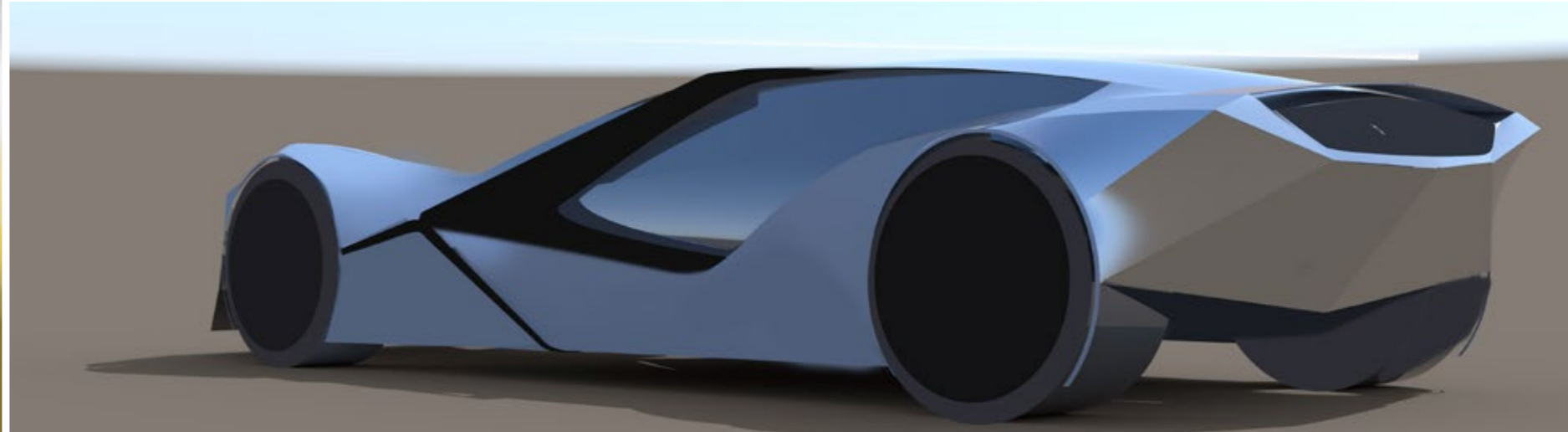

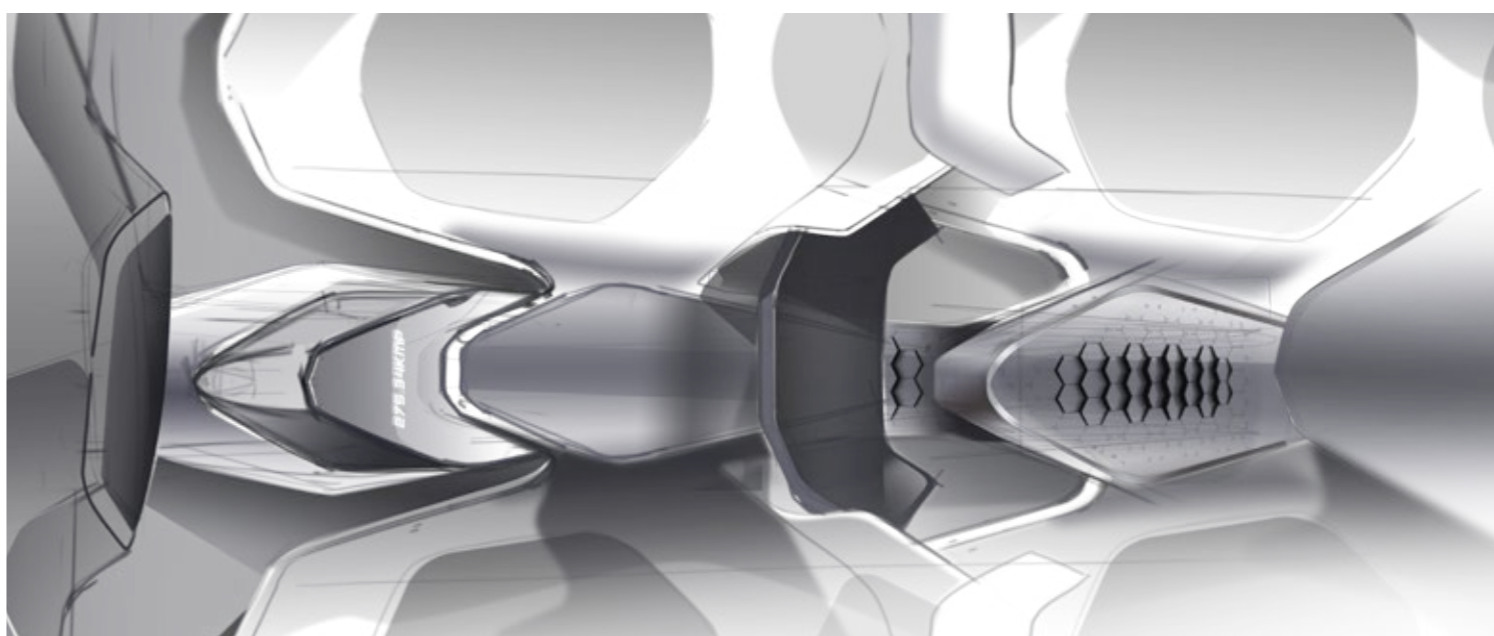
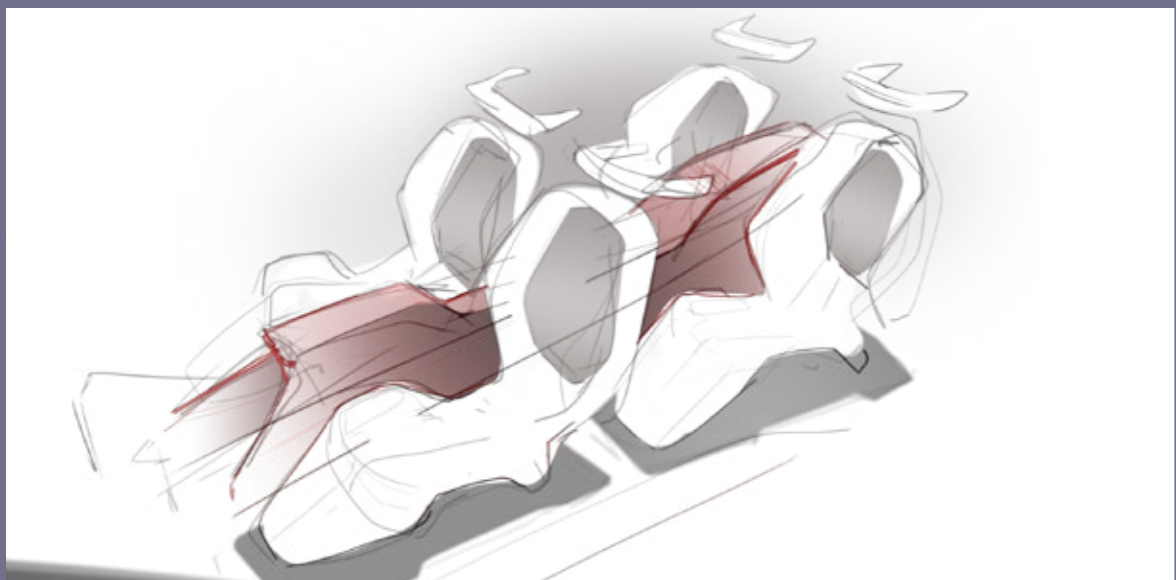
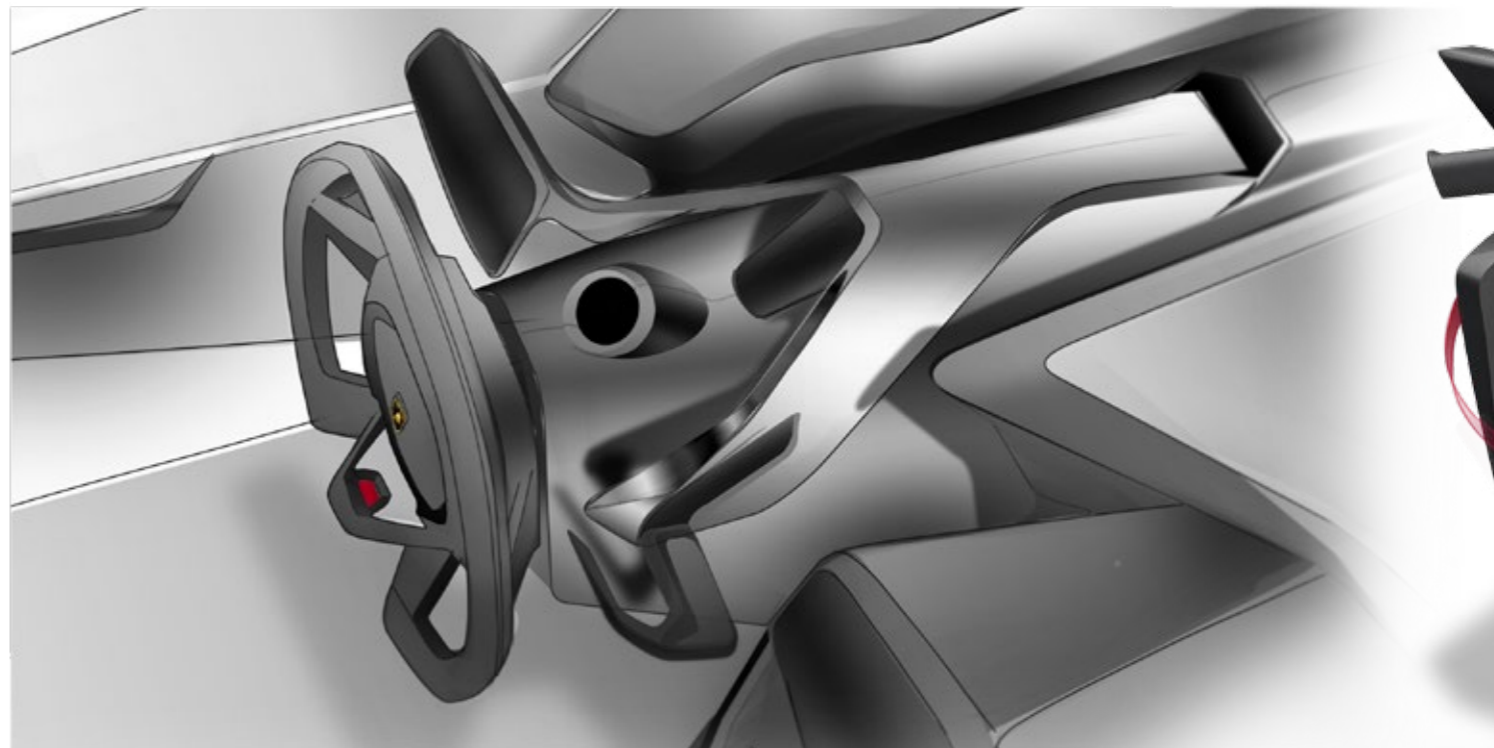
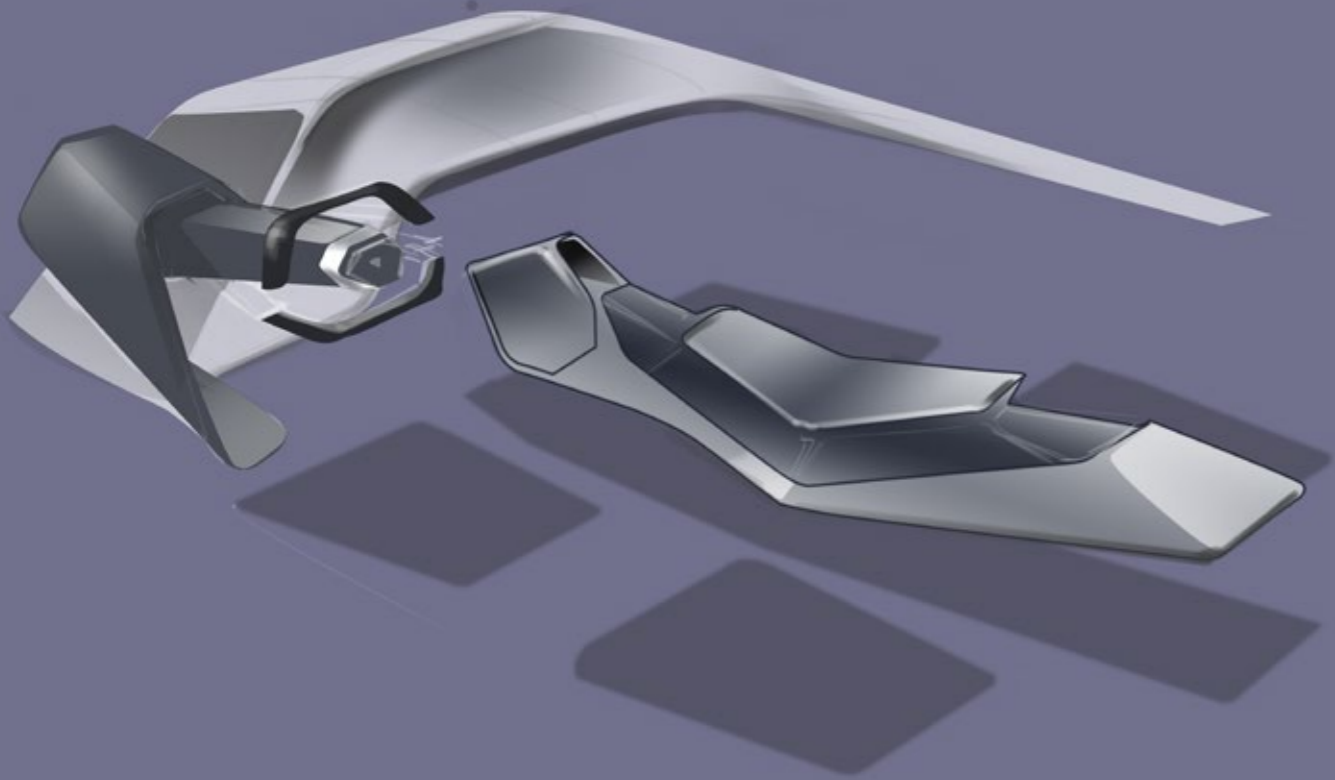

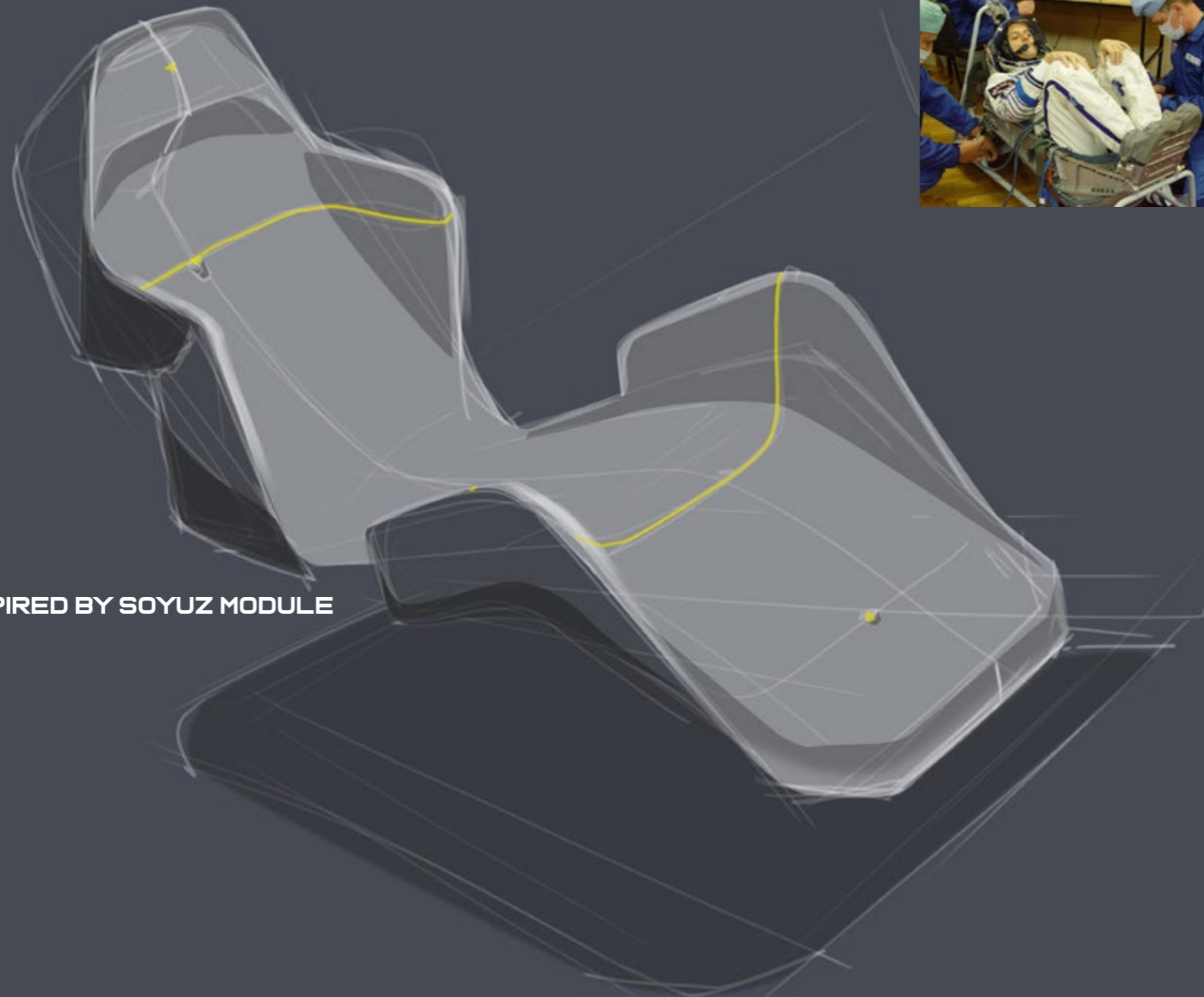

INSPIRED BY SOYUZ MODULE



THE DOOR IS INSPIRED BY THE APOLLO COMMAND MODULE

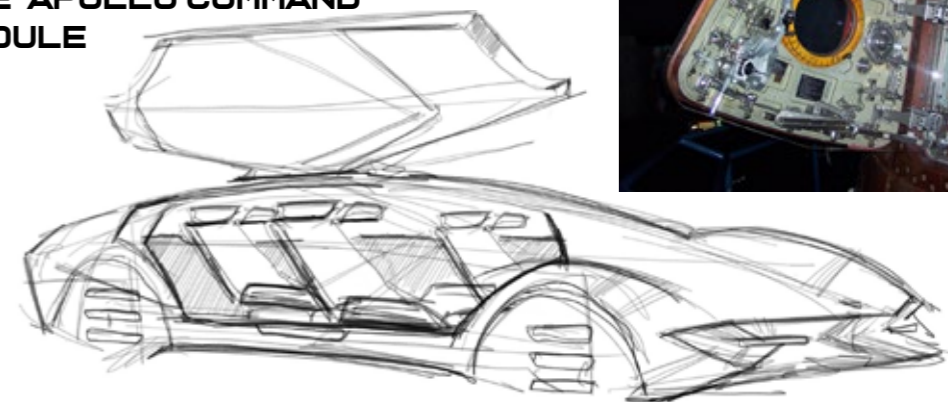

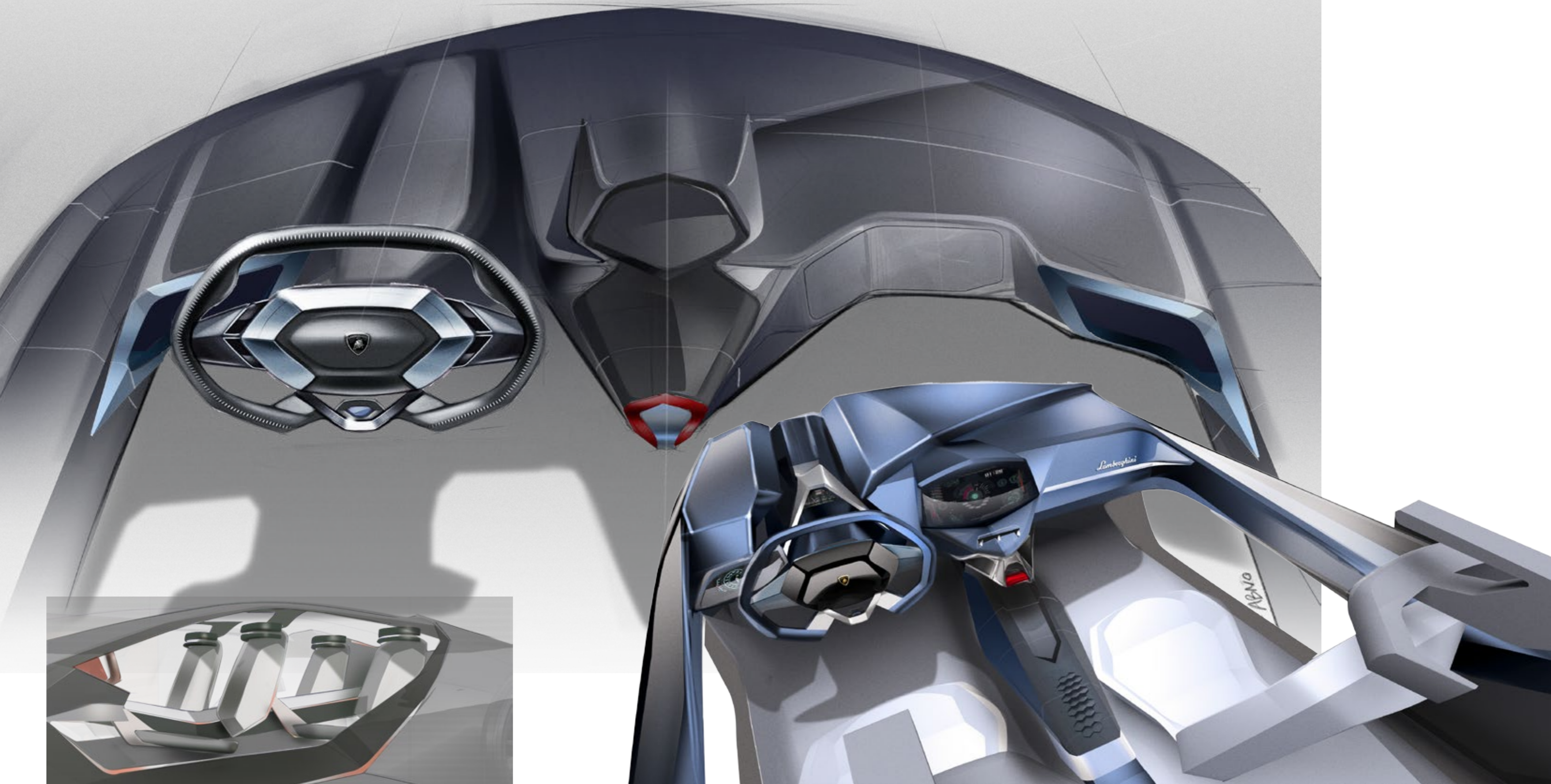

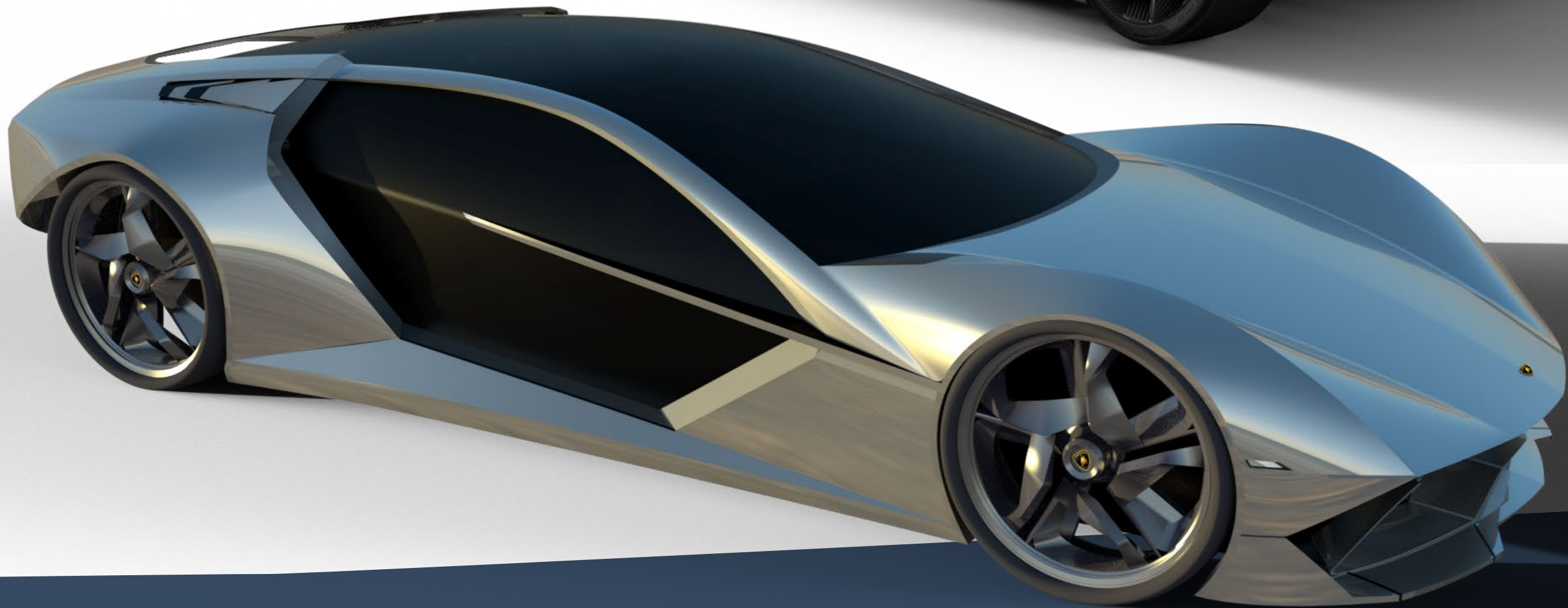

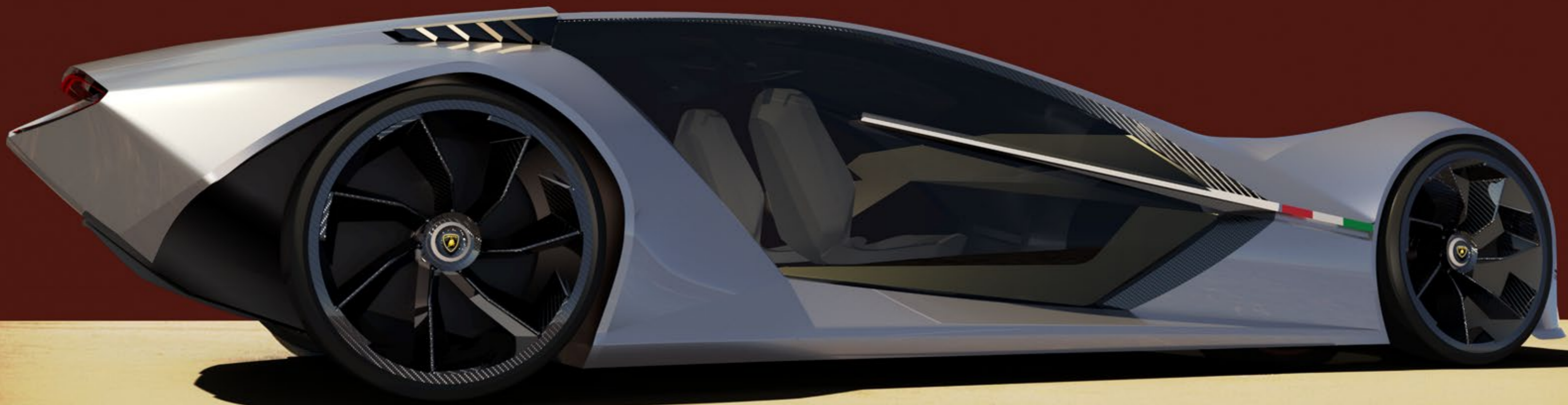





**A SUV INSPIRED BY
NAUTICAL LIFESTYLE
FOR 2040**

TENSION

**Emotion for
exterior design*

FLOW

**Design attitude .*

ORGANIC

**Emotion for
interior design*



***KEY SKETCH**

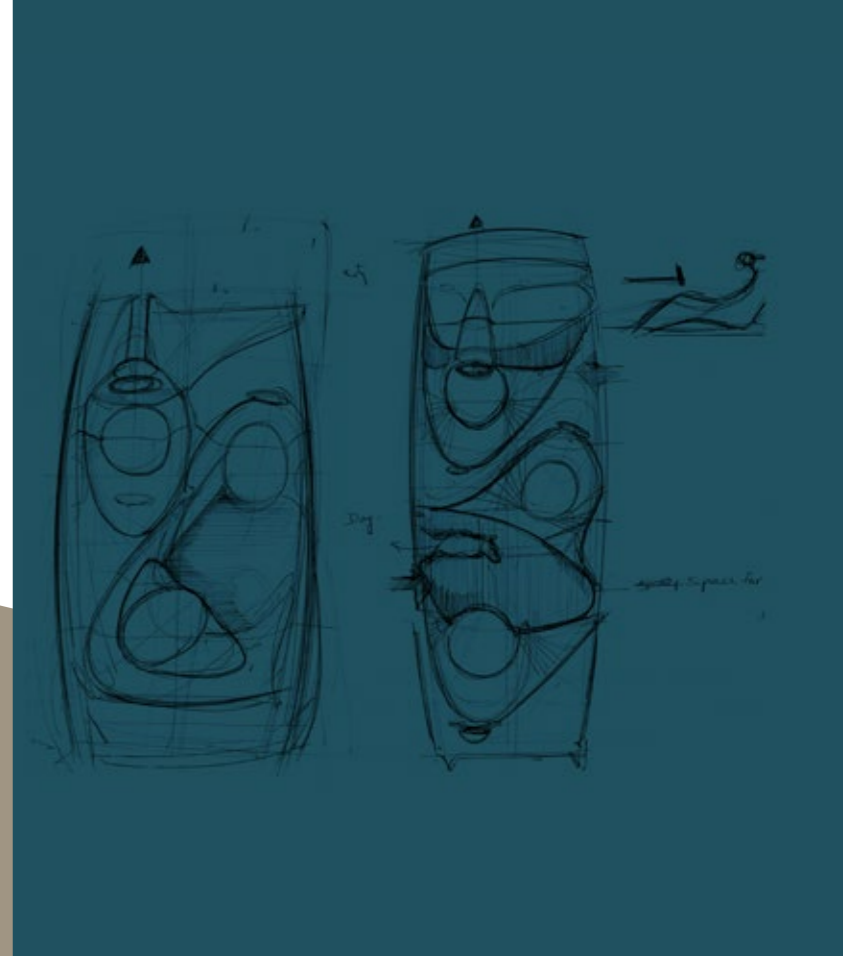
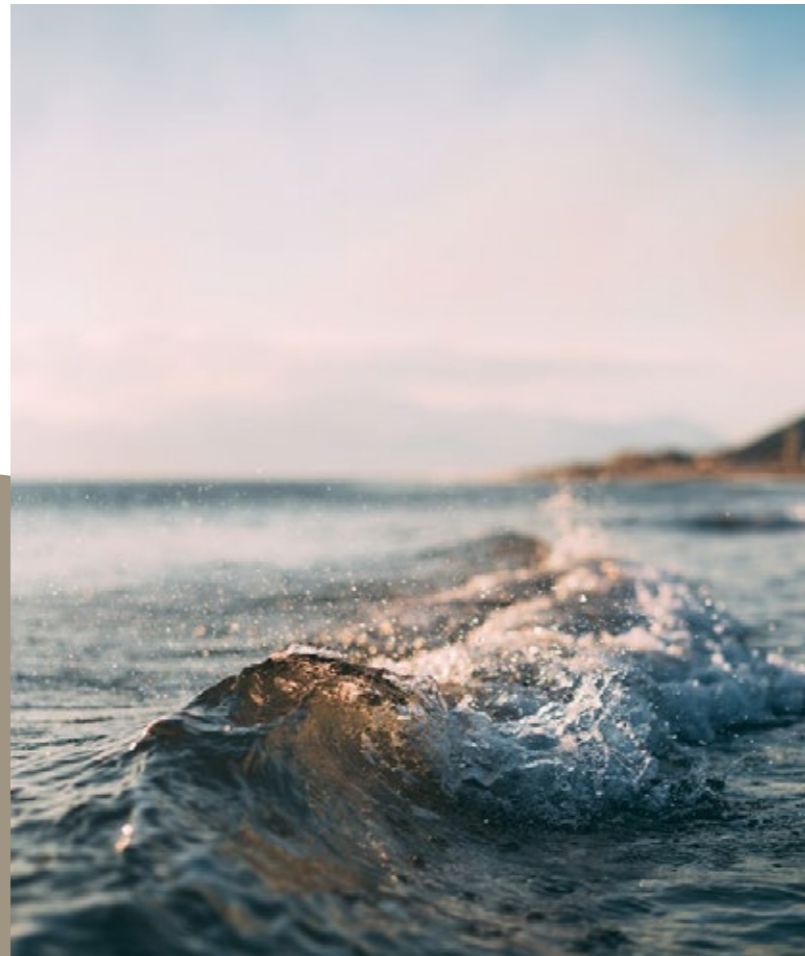
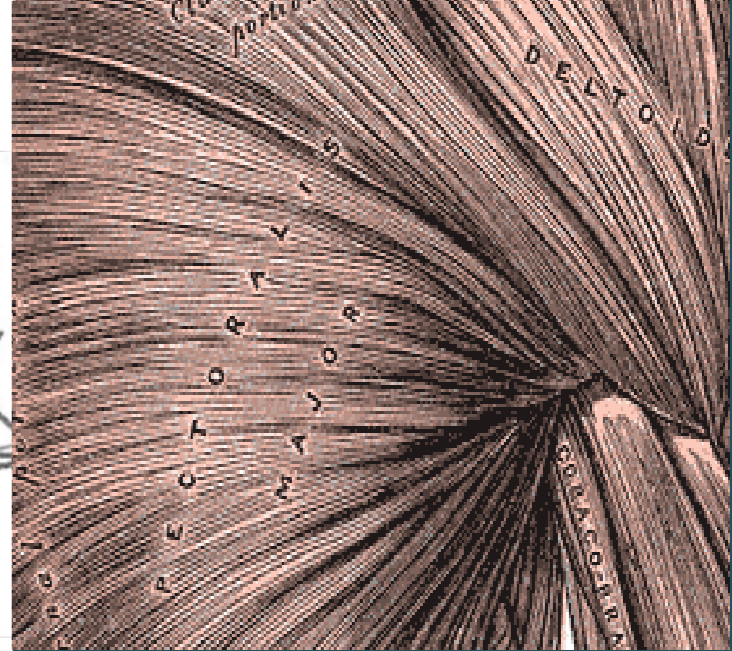
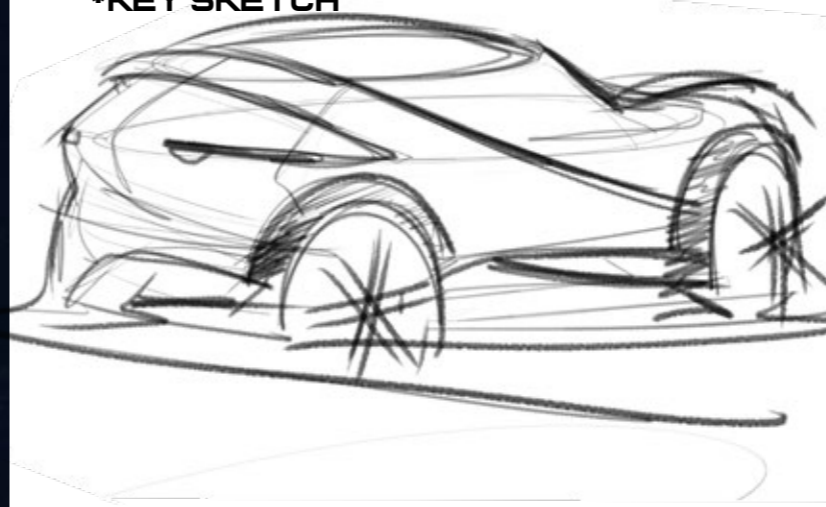





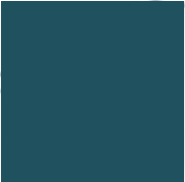

INTERIOR

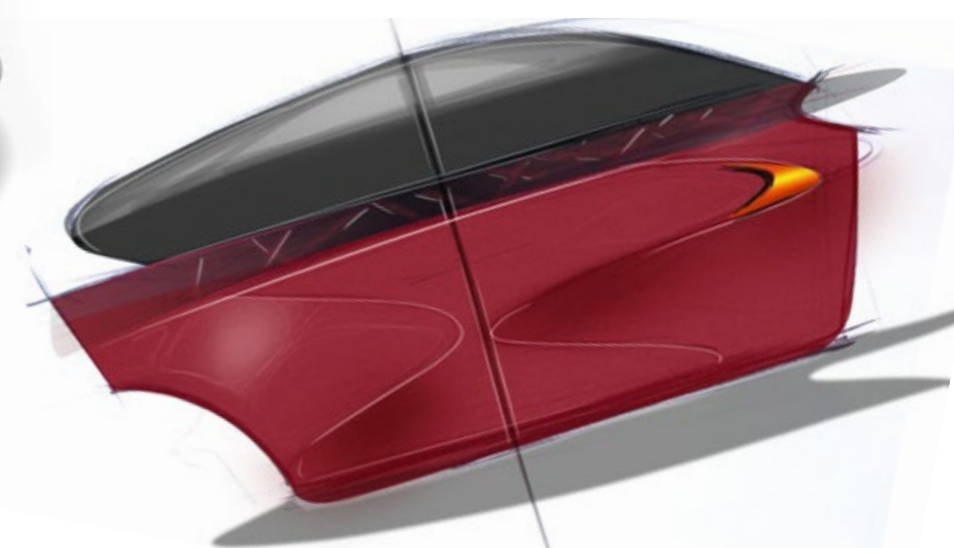
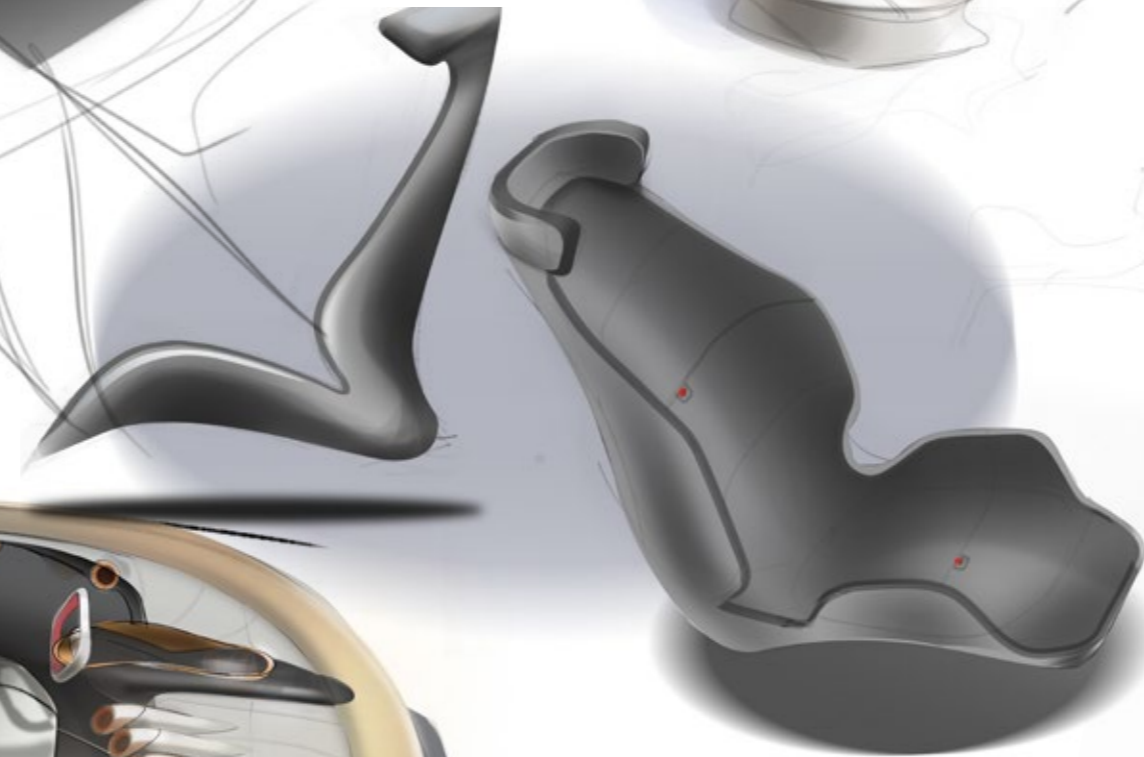
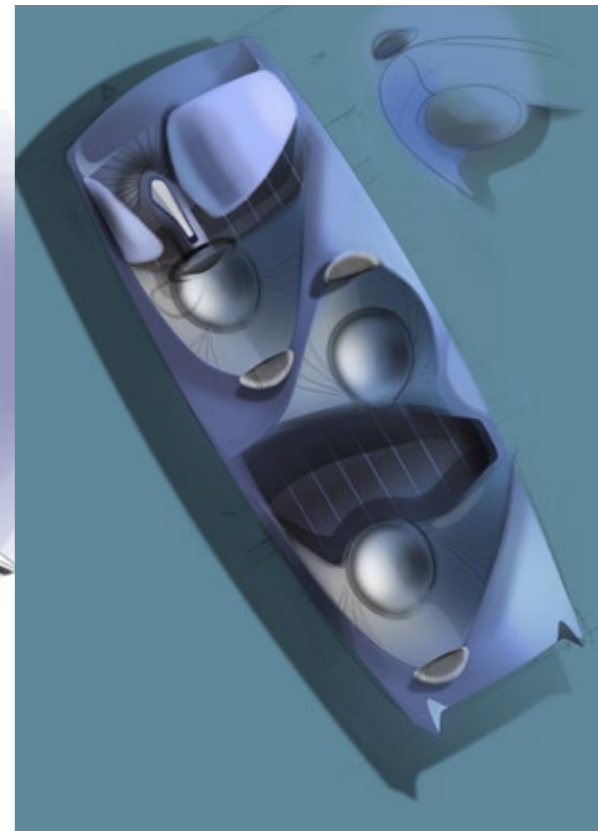
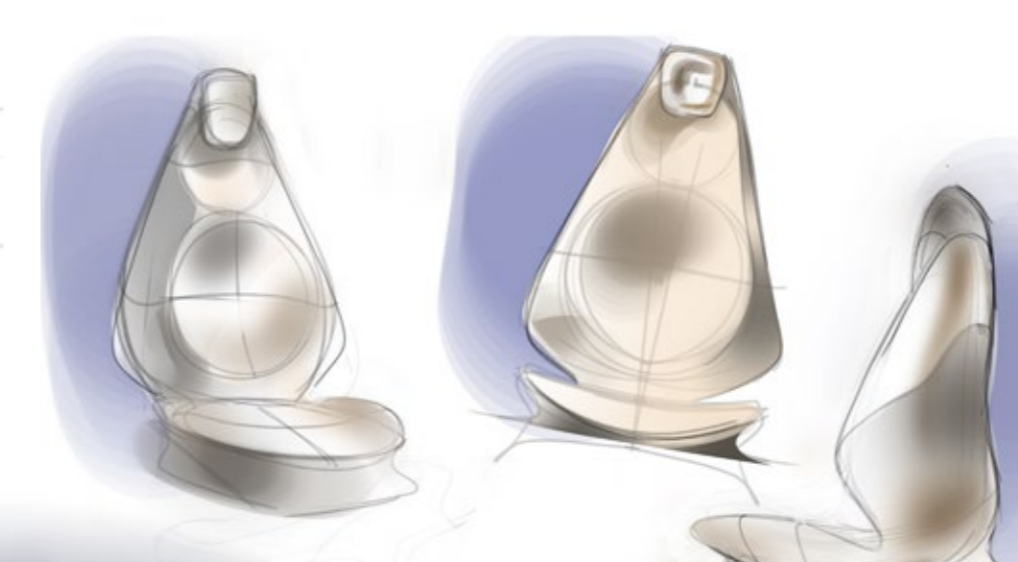
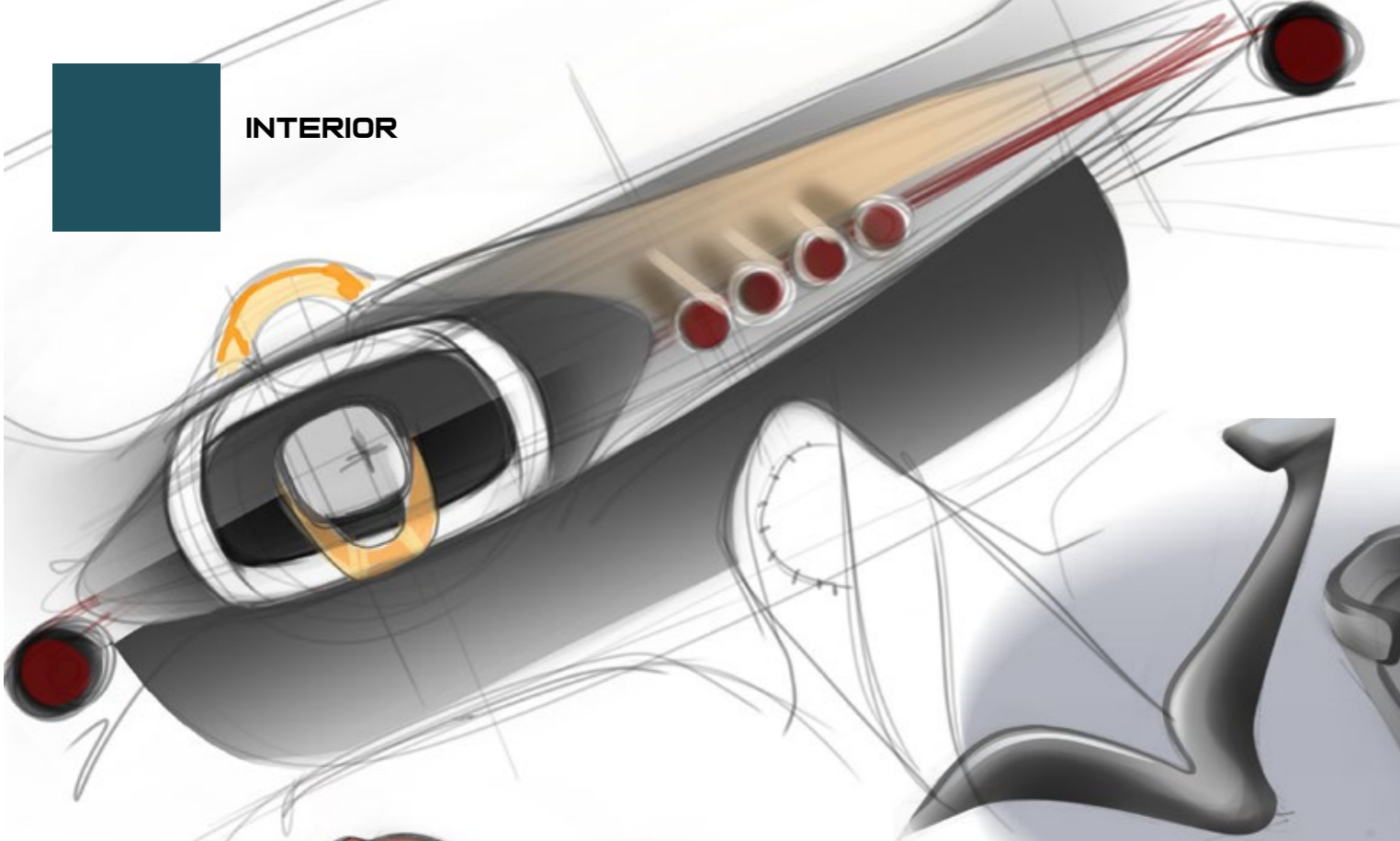

* ORGANIC FEELING

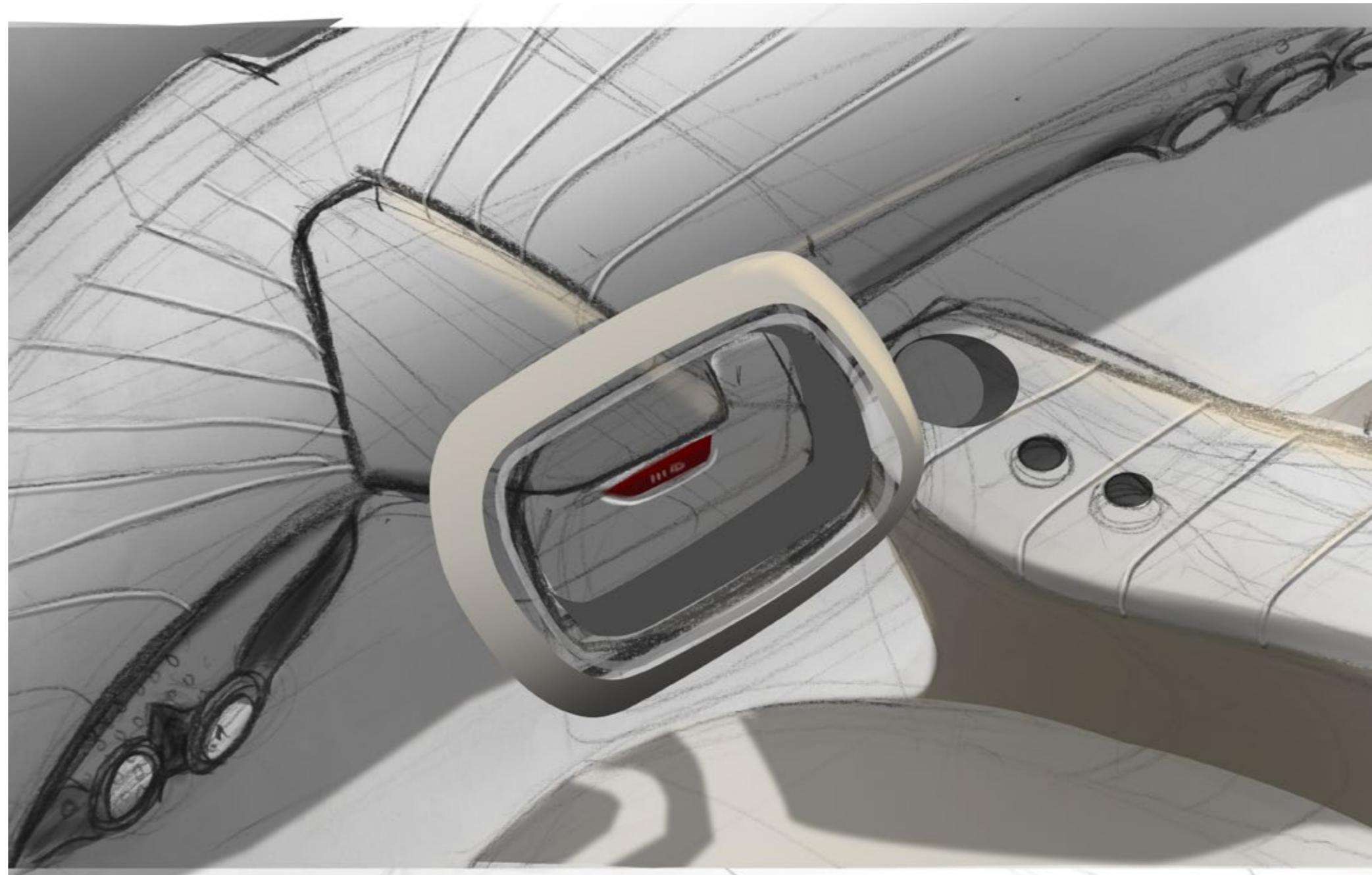
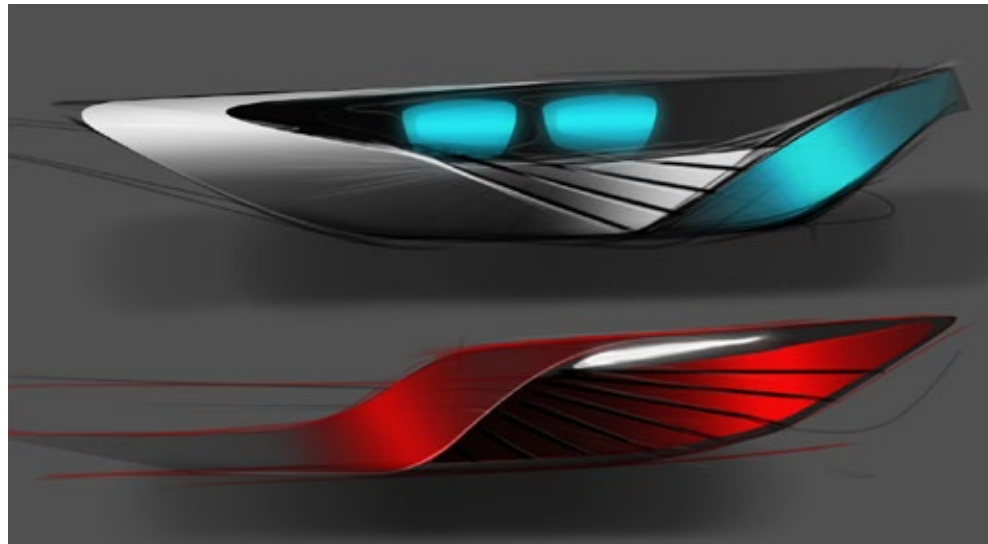

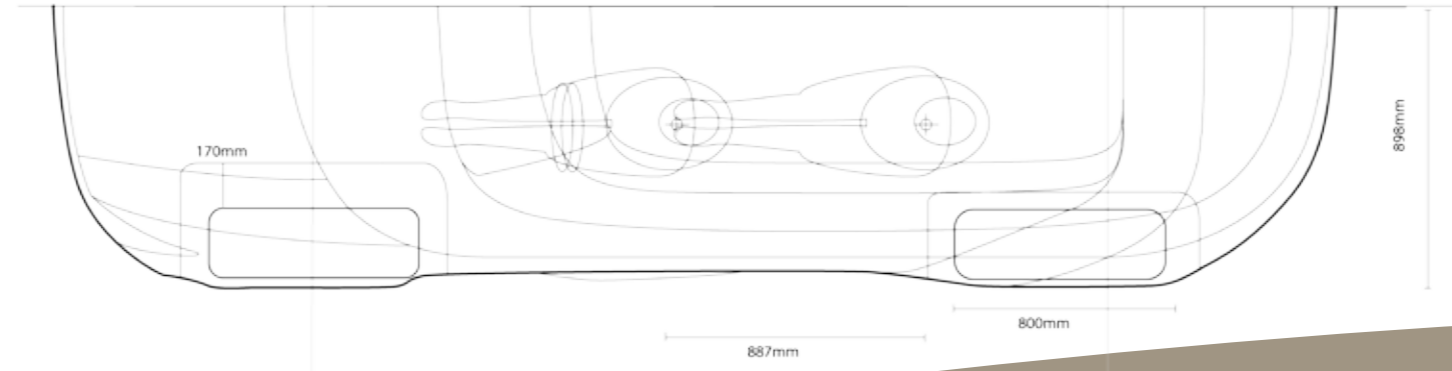
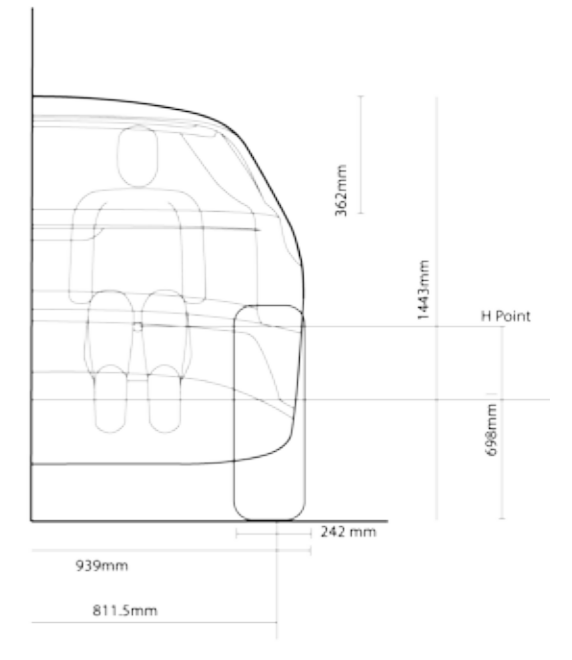
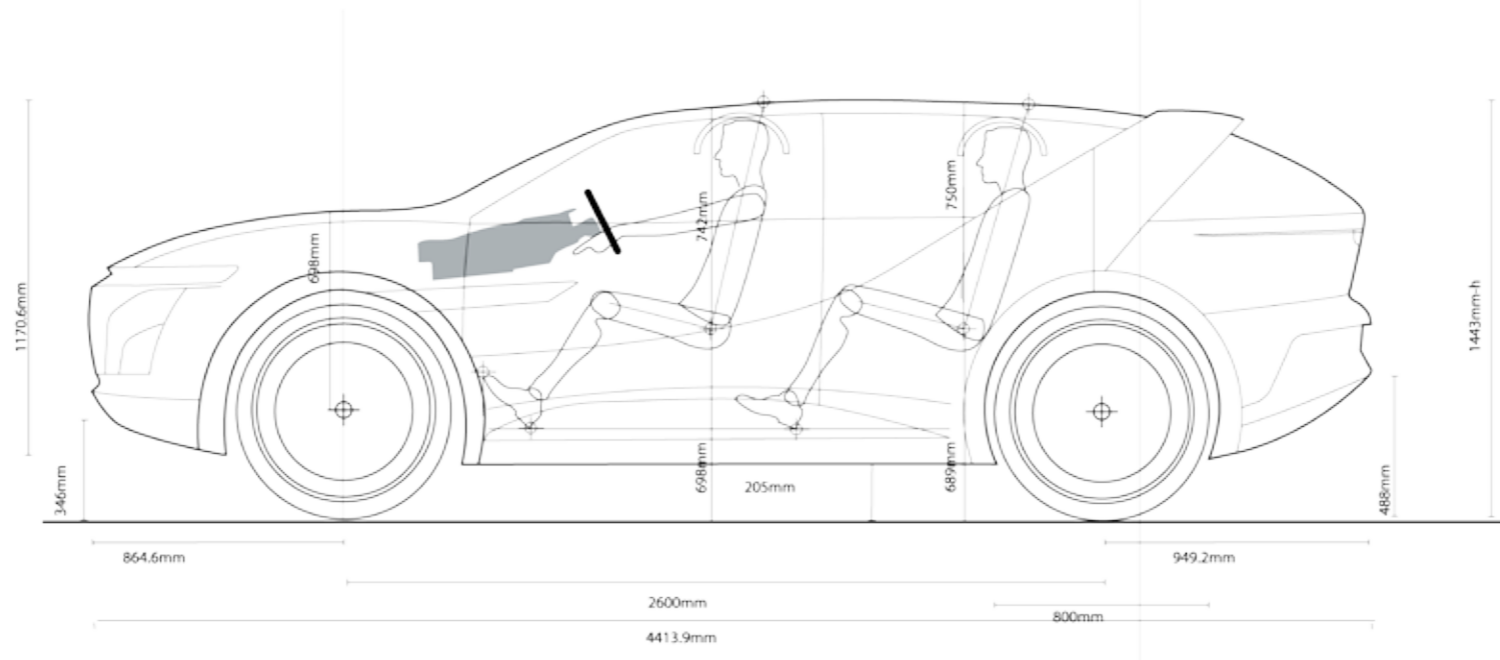
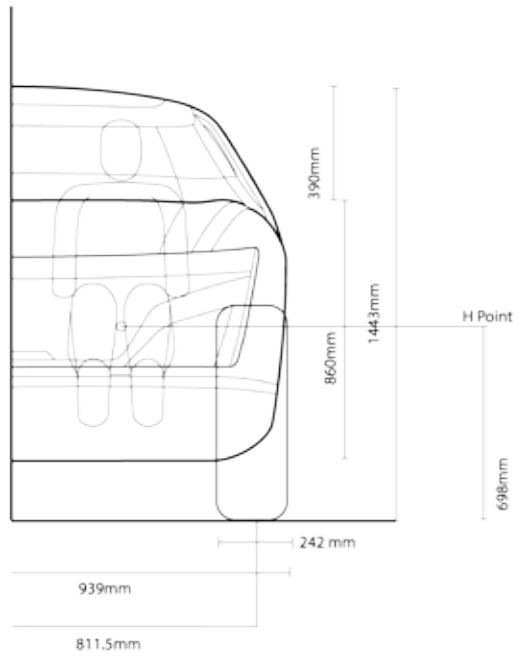

PACKAGE



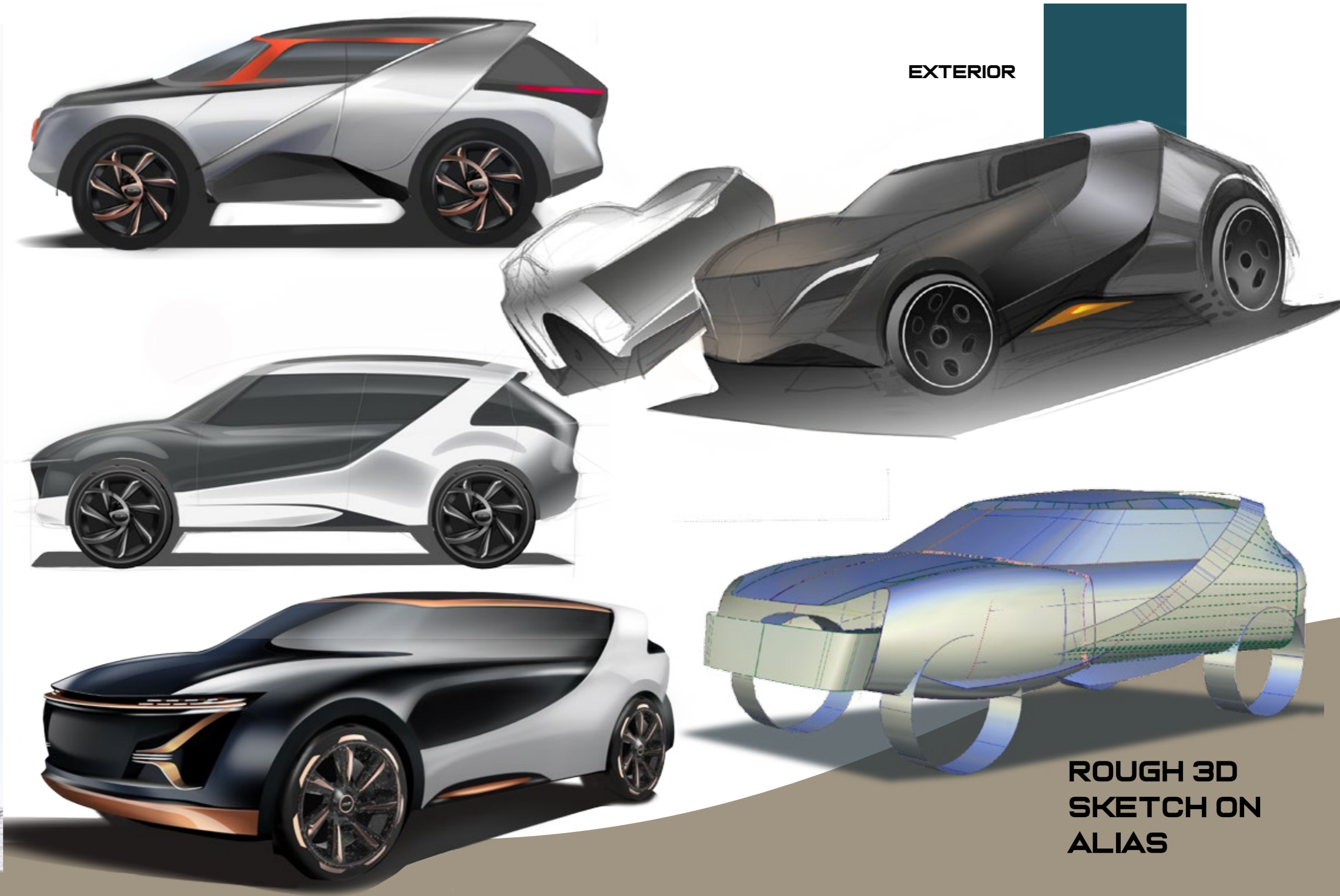

EXTERIOR

ROUGH 3D
SKETCH ON
ALIAS







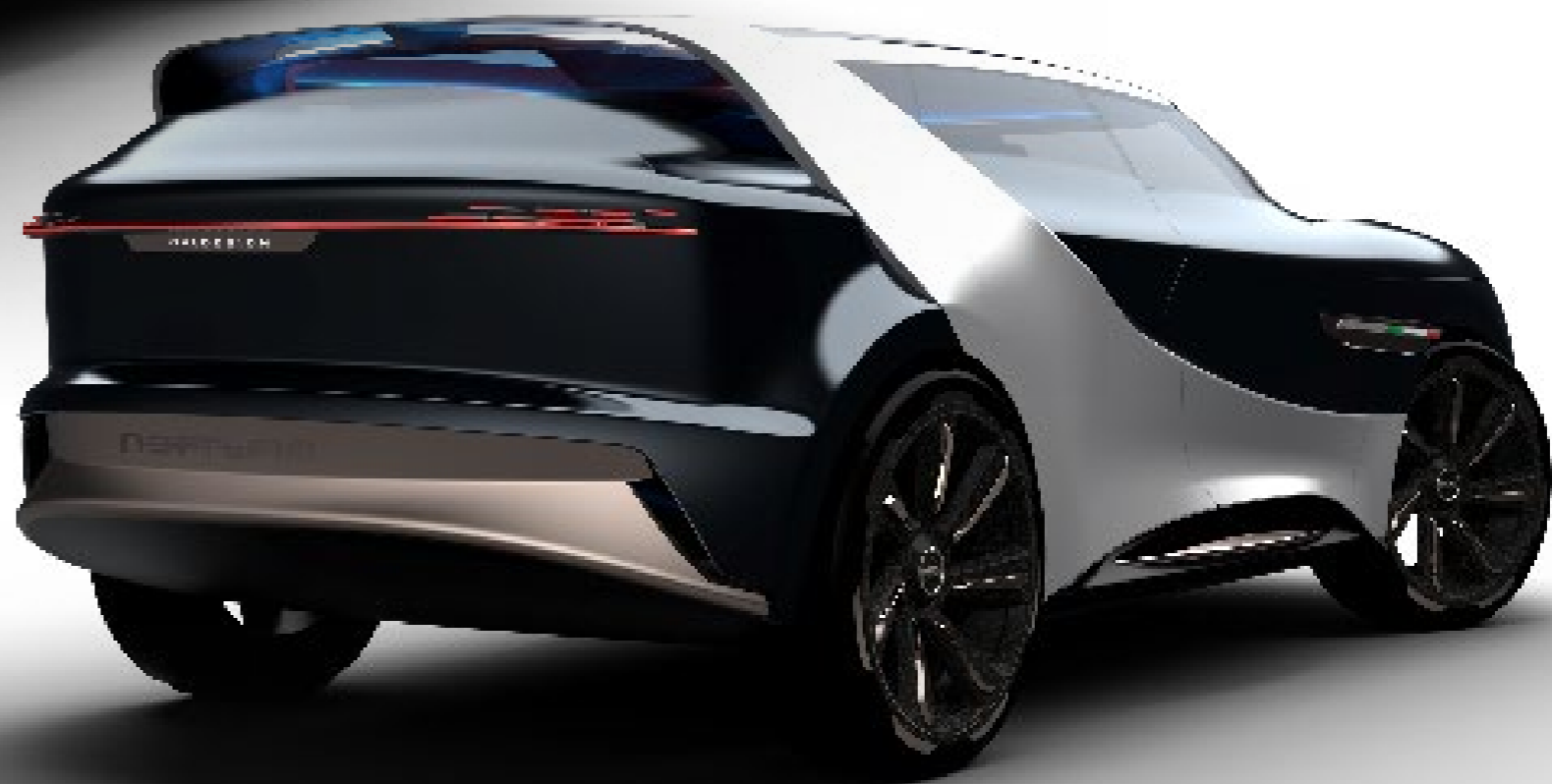





LIGHT , ENERGITIC , SIMPLE



DUAL-SPORT ELECTRIC DUCATI FOR 2035

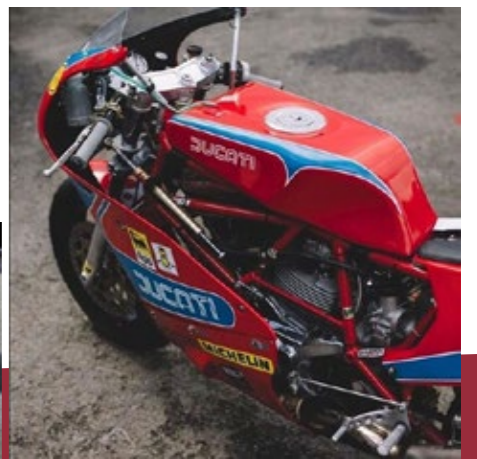
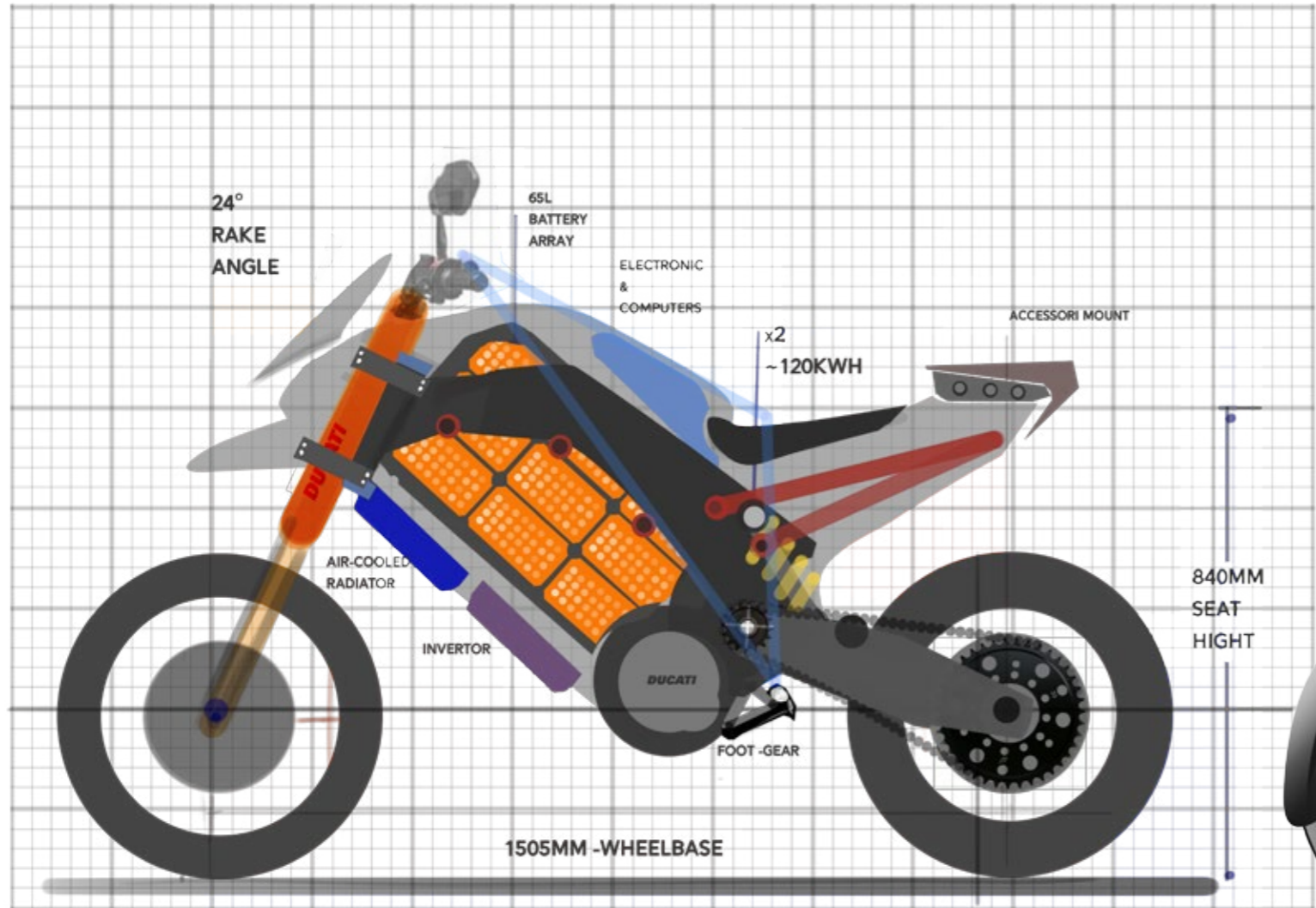

PACKAGE

PIRELLI SCORPION RALLY STR 120/70 R19

PIRELLI SCORPION RALLY STR 170/60 R17

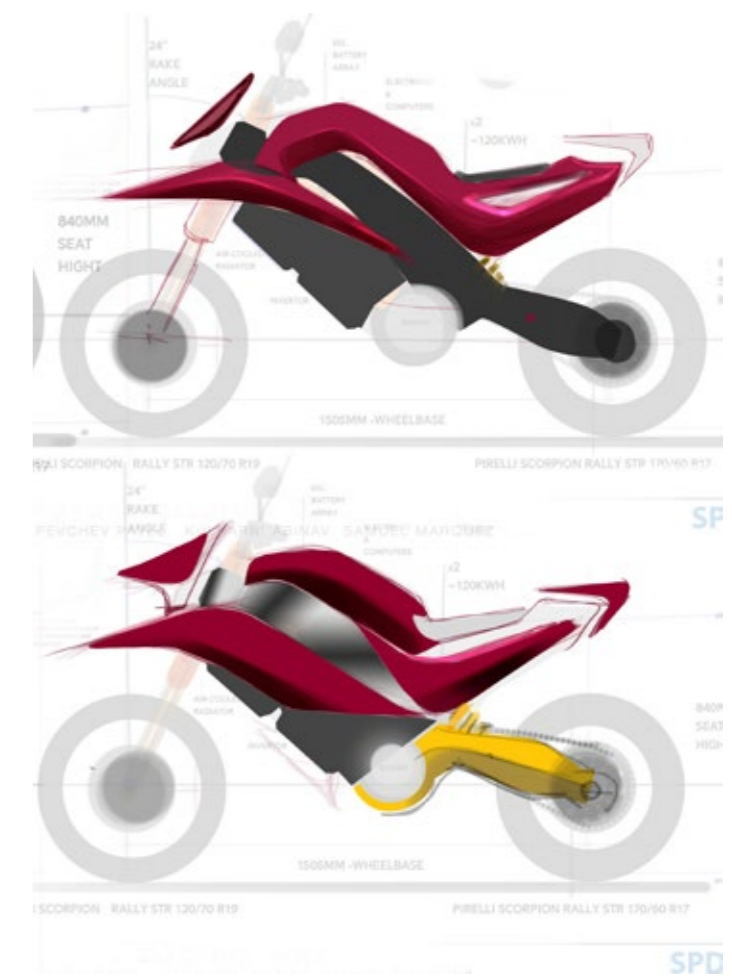

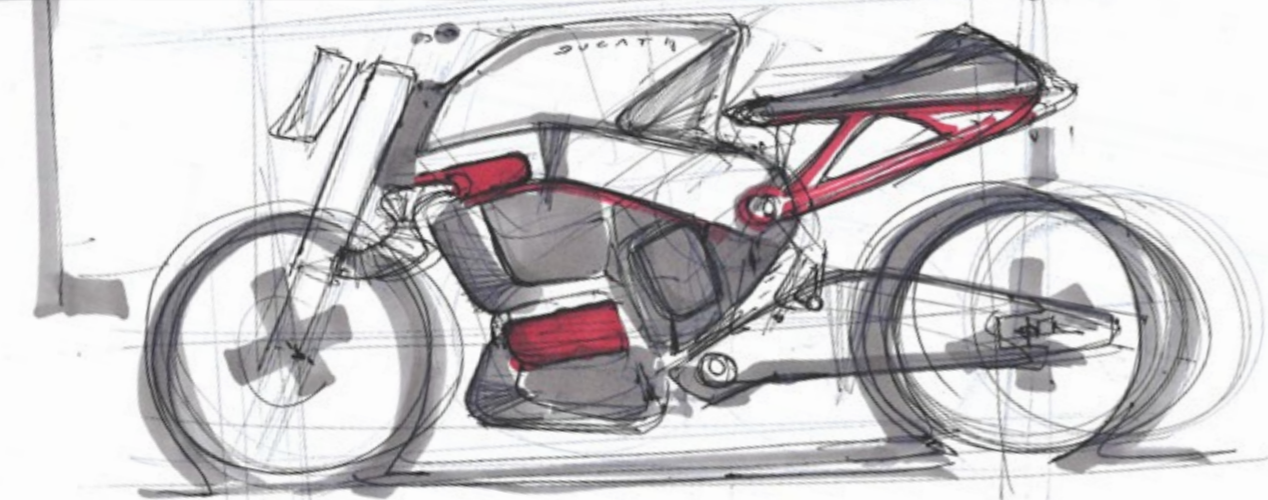
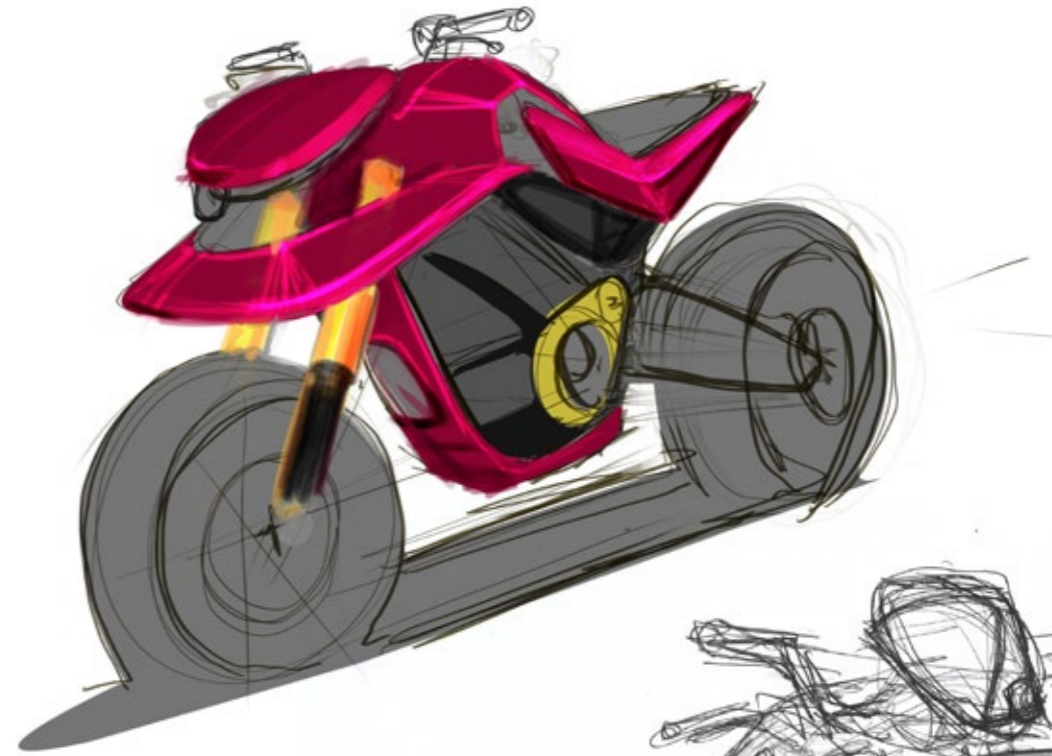
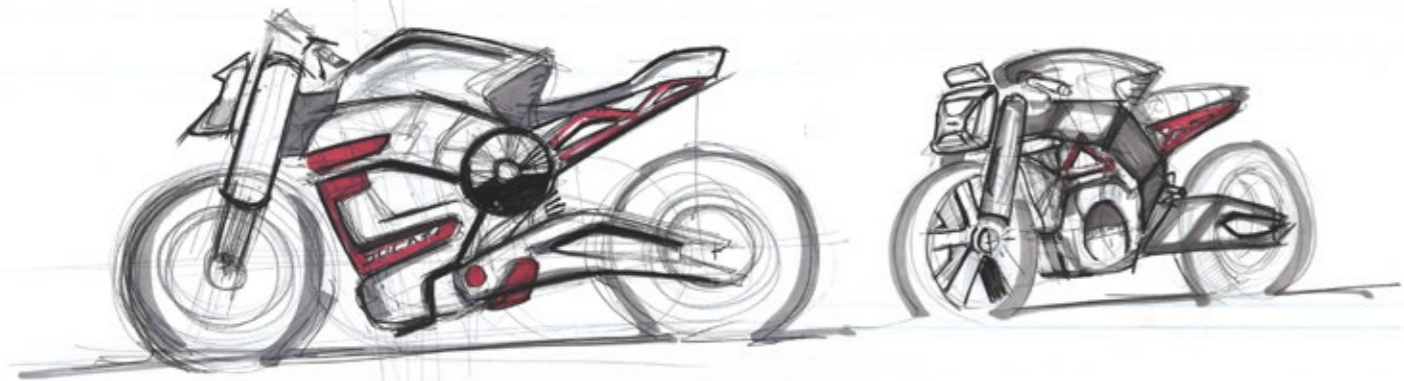

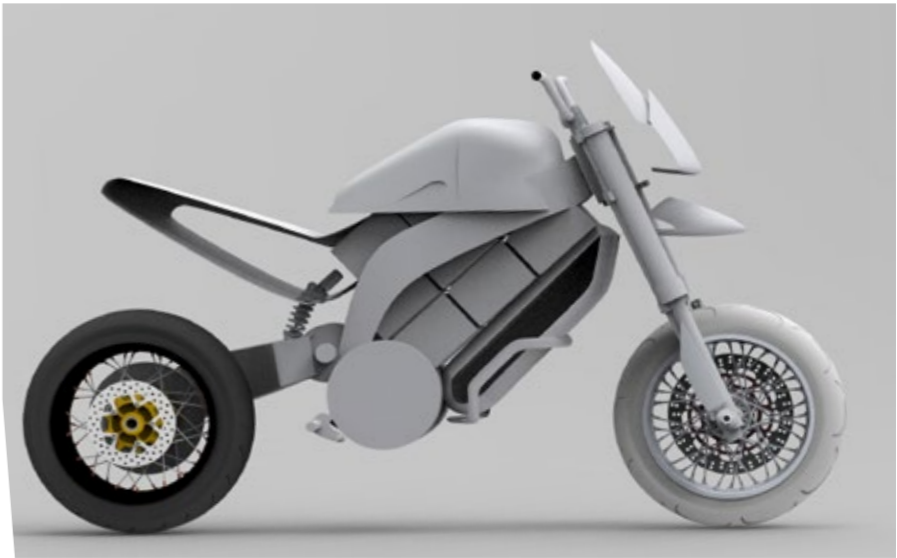

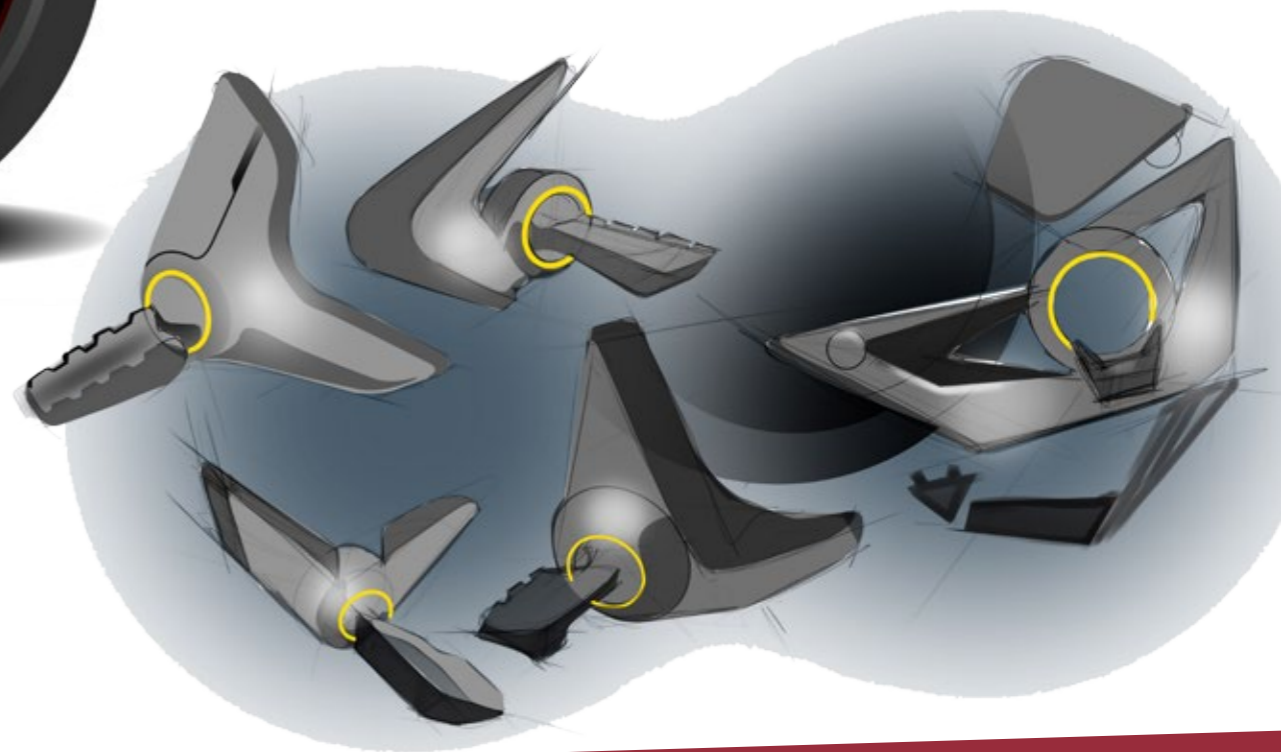
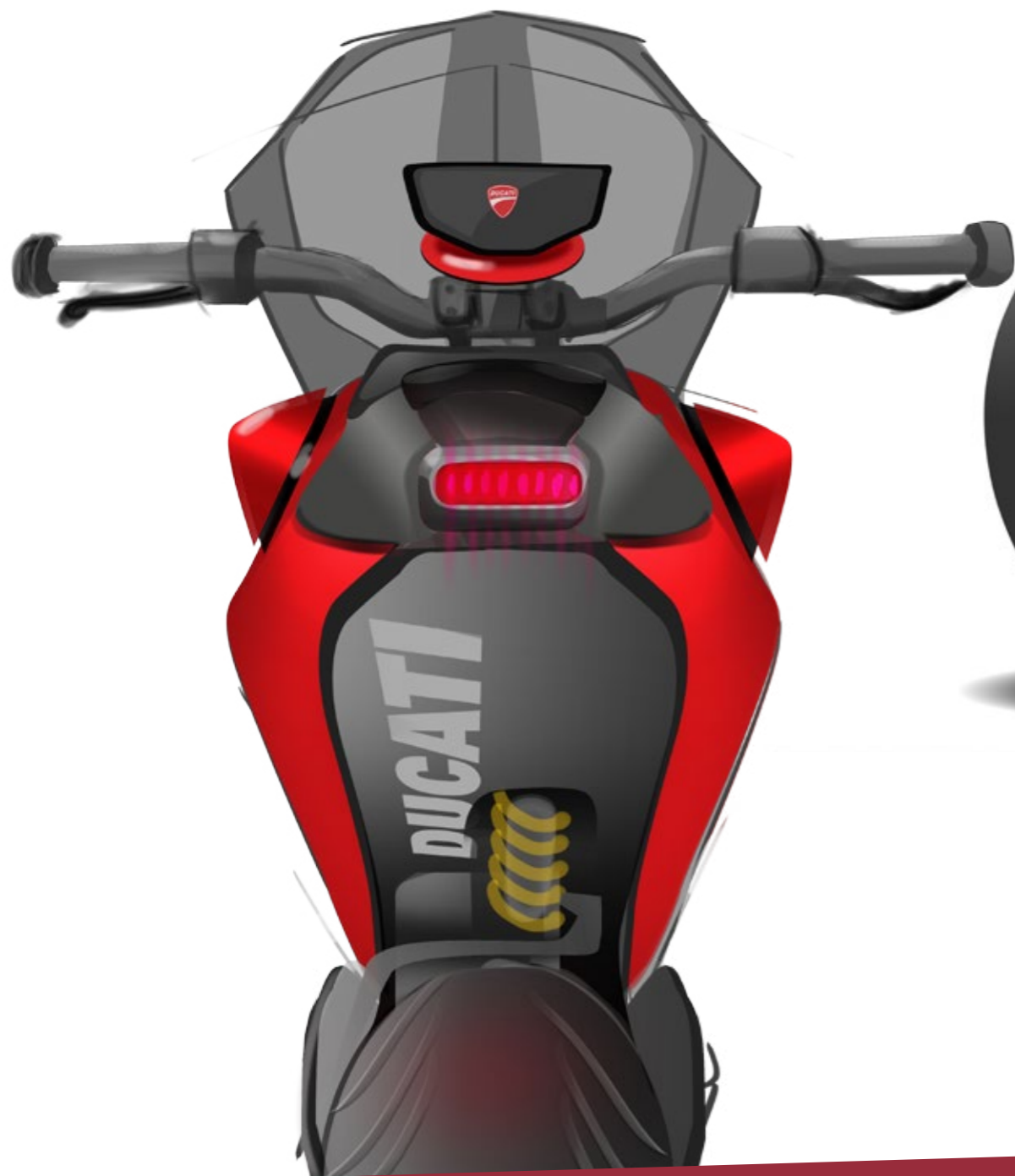



H.U.D

NAVIGATION TOGGLE

PHONE NAVIGATION

START STOP

LIGHTS TOGGLE





C.M.F POSTER

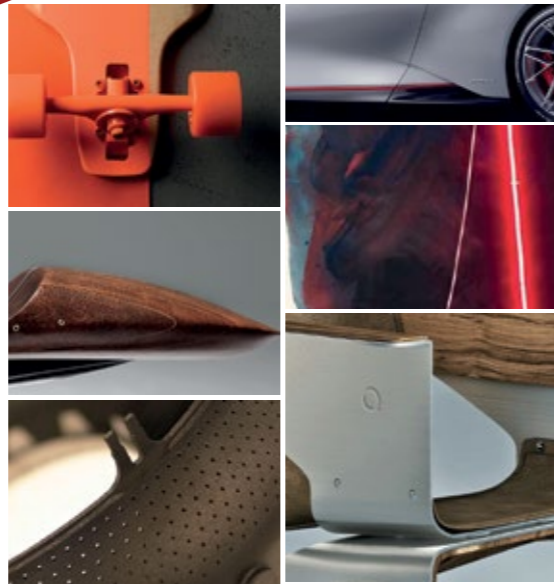

Colour Palette

1 0 95 94 28	2 69 53 46 22	3 47 73 48 67	4 0 19 79 0	5 100 0 38 2
6 4 2 4 8	7 23 16 13 46	8 40 30 20 66	9 0 0 0 94	

Exterior Colour Harmony

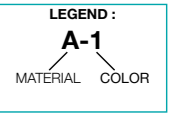

A



Material : Aluminum
Finishing : Combination of satin and high gloss
Process: Anodization
Color: PANTONE 19-4517 TPG (69-53-46-22)
Accent : PANTONE 7620 C (0 95 94 28)

B



Material: High-density fibre polymer or high-density Hemp -
Finishing: Textured hard fabric
Color: PANTONE Cool Gray 10 C and 9 C (CMYK 40 30 20 66) (CMYK 0 0 0 94)

C



Material: Aluminum and magnesium
Process: Metal forge
Finishing: Gloss, Power finish.
Color: PANTONE 1225 C (0 19 79 0)



E



Material : Softwood and foam
Process : Natural wood pressed with foam
Finishing : Dark Smooth Walnut
Color: PANTONE 2478 C (47 73 48 67)

F



Material: Aluminium sintered powder
Process: Additive manufacturing
Finishing: Raw sintering finishing
Color: PANTONE Cool Gray 8 C (23 16 13 46)

G



Material : Hard ABS Plastic
Process: Injection Moulding
Finishing: Gloss
Color: PANTONE Cool Gray 1 C (4 2 4 8)

H



Material : Coring glass
Finishing : Gloss
Color: PANTONE Cool Gray 10 C (40 30 20 66)

I



Material : Translucent Film
Finishing : Translucent gloss
Color: PANTONE 19-4517 TPG (100 0 38 2)

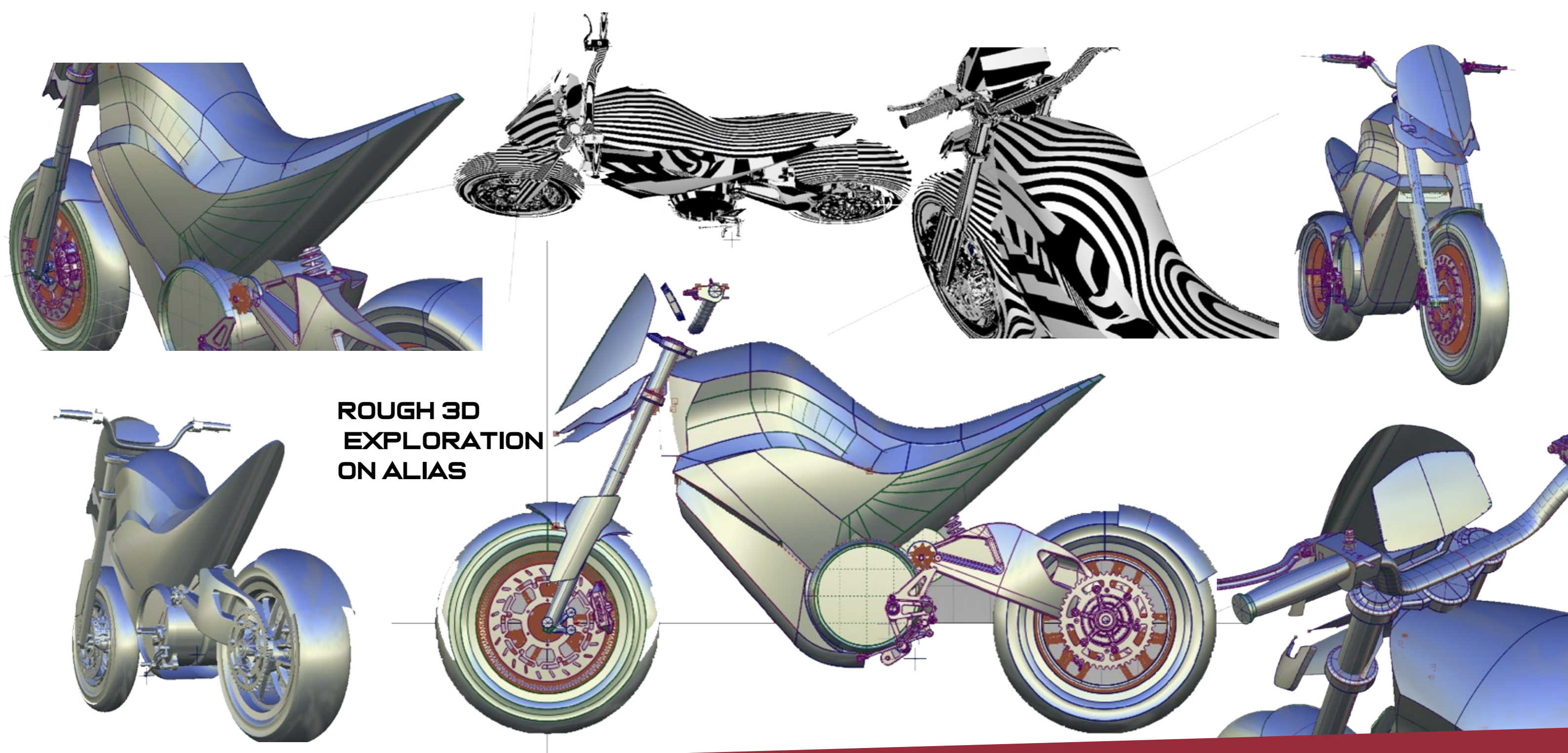

**ROUGH 3D
EXPLORATION
ON ALIAS**



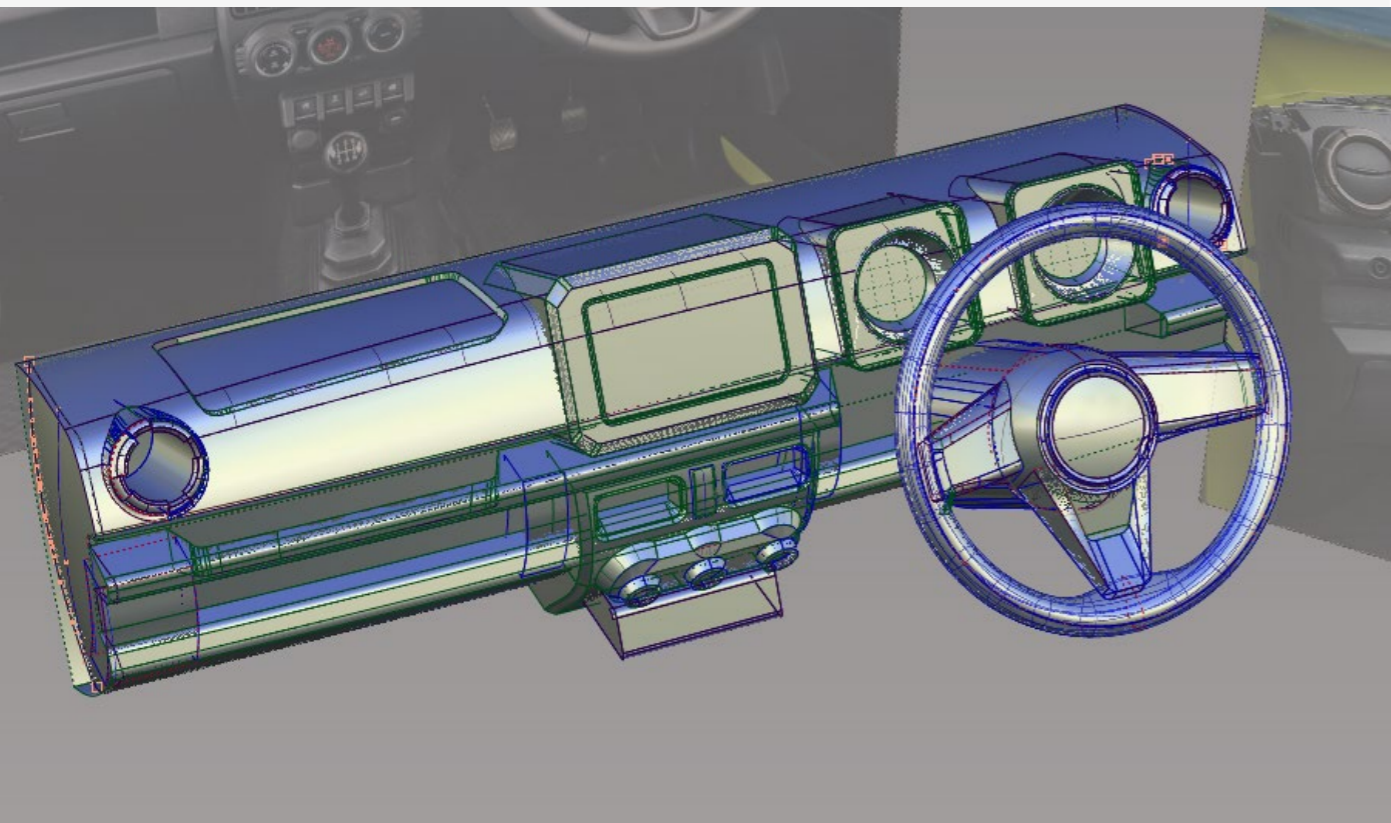
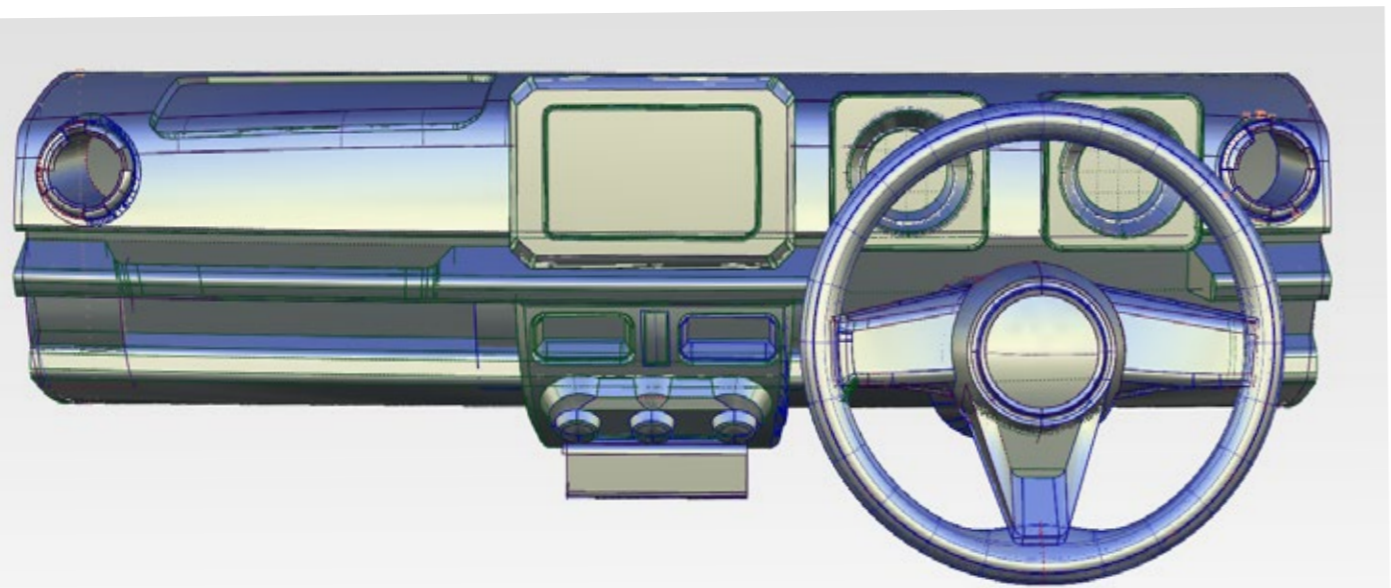

SUZUKI JIMNY DASHBOARD - 3D PRACTICE



PHOTOSHOP RENDERING - PRACTICE



ABOUT ABHINAV :



CONCERNS AND ANXIETY

- “How do I communicate better with people? Am i being **authenticity**? “
- “How do I **empathise** and put forth my voice of concern ?”
- ”What am I **speaking** ? is it an opinion? or is it an inherent bias?”
- “-Am I being egocentric for my convince? “
- ”How can I be a better human ? “

Explore: -Classic cars and history of mobility,
-Biomimicry, Nature’s System design
- Anthropology, study of human behavior.

Movies : Andrei Tarkovsky, Robert Bresson, Terrence Malick

Music: Radiohead, J-Dilla, Brian Eno, Bob dylan, Greatful-dead, John Coltrane, chet baker, BADBADNOTGOOD, Funkadellic ...etc

Instrument: Improv composition on 4 piece jazz drum set.

Books: Fyodor Dostoevsky, Jean-Paul Sartre, Jiddu Krishnamurti, Friedrich Nietzsche, Ayn Rand, Aldous Huxley

Inspiration : Neri Oxman ,Buckminster fuller, David Attenborough and Bob Dylan

Meditation: I sketch without intent or expectation.



HOBBIES AND INTERESTS

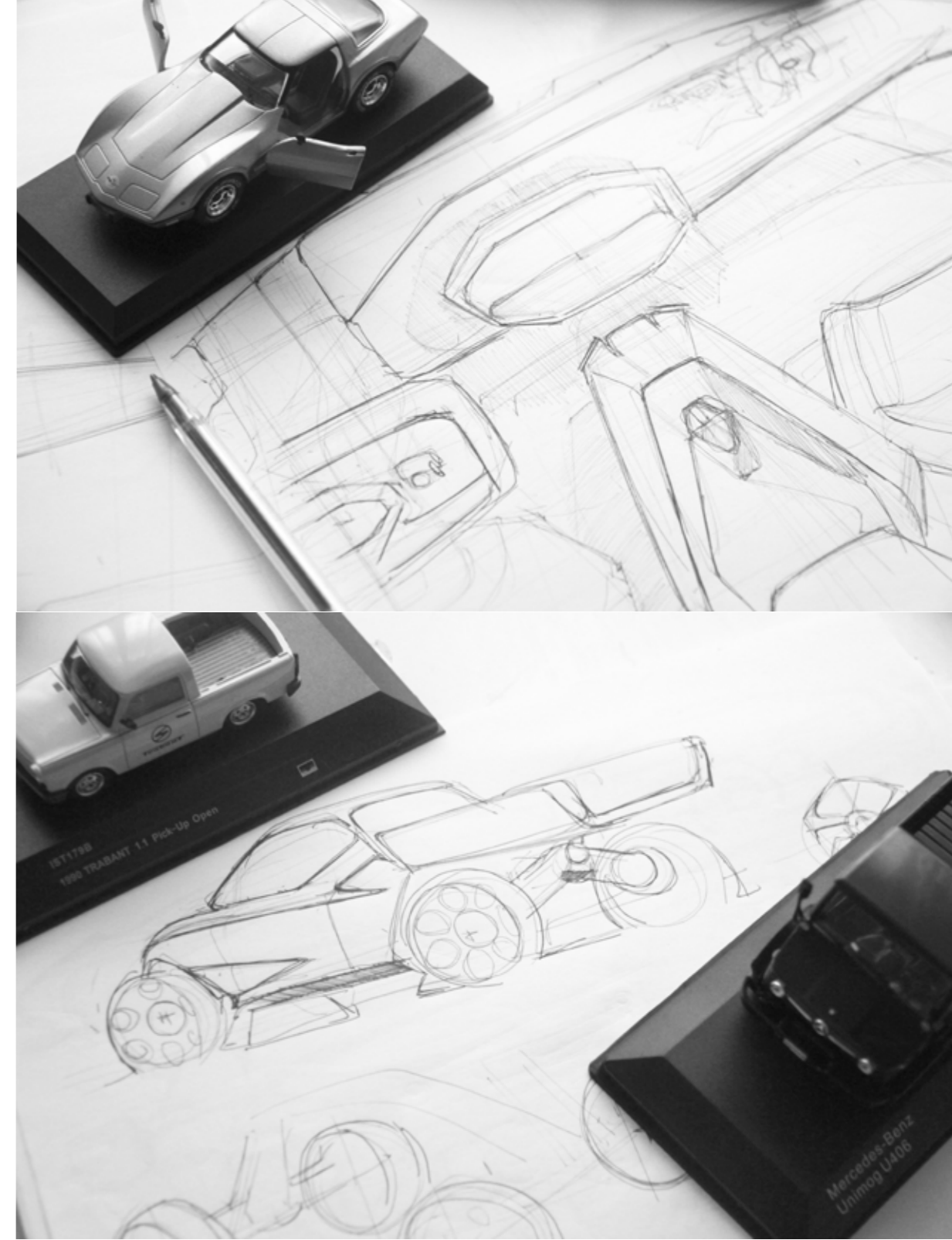

COURSE OF LIFE (CV) :

EDUCATION

Car & Transportation design
Graduation- Masters (2018-2019)
Scuola Politecnica Design SPD
(Milano, Italy)

Transportation design
Undergraduate- diploma
(2011-2017)
MIT Institute of Design (Pune, India)

FIIT-JEE
+2(High School) (2009 -2010)
(Hyderabad-India)

Bhavan's Sri RamaKrishna
Vidyalaya (Primary school)
(2003-2009)
(Secunderabad-India)

ACHIEVEMENTS

National Cadet Corps (A-certificate)(2007)

State level school science fair
(model making)
(runner up) (2008)

exchange program :
Strate Ecole de Design
mobilité design (2015)

BIO

Language proficiency :
English (fluent)
Hindi, Kannada, Telugu (basic)
French, Italian (below basic)

Date of birth :
Spring equinox
March 20th 1993

PRESENTATION

2015 -classroom project,
Renault Technocentre, (Paris, France)
2016-TATA Design studio (Pune, India)
2019- Lamborghini Centro Stile
(sant'agata bolognese, Italy)
2019- Ducati Design center(Bologna, Italy)
2019- classroom project,
Italdesign (Turin, Italy)

WORK EXPERIENC

Design Consultant
Imaginarium India
August 2017 - January 2018
(7+months)Mumbai, India

Design Intern
IDE AutoWorks
July 2016 - December 2016
(6 months)Gurgaon, India

Summer Intern
DesmaniA Design Pvt. Ltd.
July 2014 - August 2014
(2 months)south Delhi

SKILLSETS

digital skill set:

Digital Sketching(Cintiq)
Autodesk alias
autodesk Vred
Autodesk 3ds max
Autodesk maya
Autodesk Netfabb
ZBrush
Key short
Autodesk fusion 360
Adobe Photoshop
Adobe Illustrator
Adobe InDesign
Adobe premier
Ultimaker Cura
Structer sensor 3D Scanning

manual skill set:

Research
Design Thinking
Sketching
Marker Rendering
Tape drawing
Basic clay Modeling
Photography
3D print process
Sanding
hobby Airbrush

CONTACT INFO

Name :Abhinav kulkarni
email : abno2266@gmail.com
website : www.abnoabhinav.com

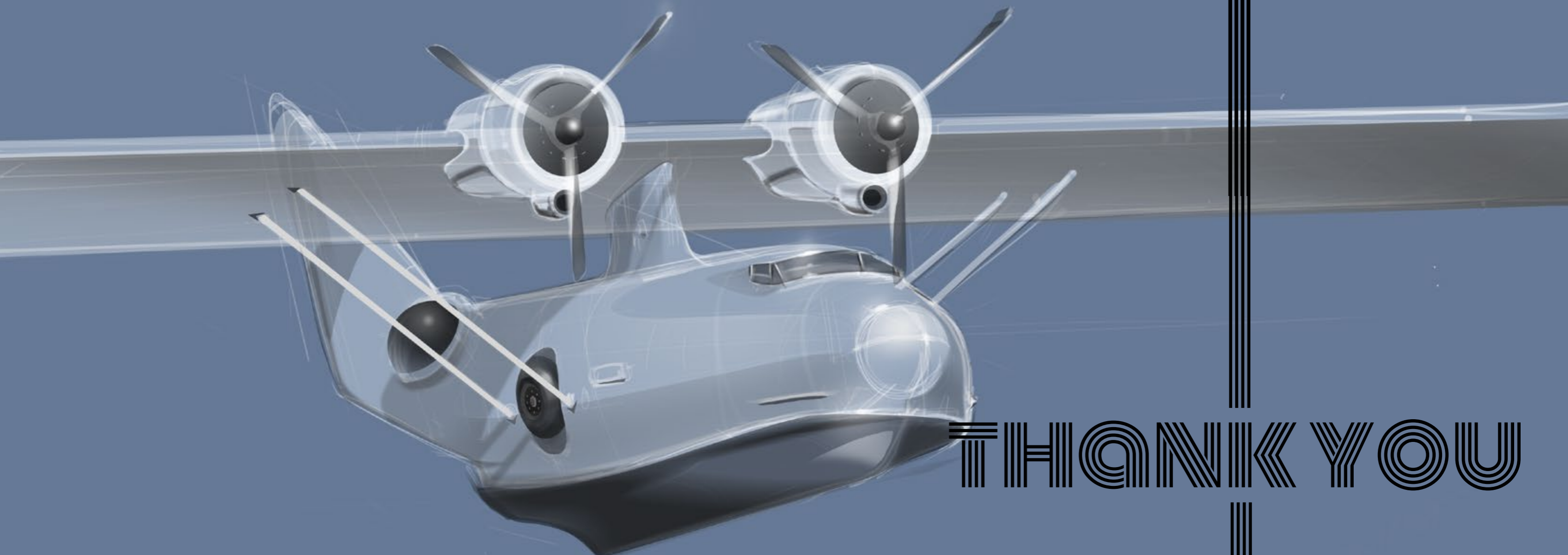

THANK YOU



www.abnoabhinav.com